



Wavin Plastics Limited

Parsonage Way
Chippenham
Wiltshire SN15 5PN
Tel: 01249 766600 Fax: 01249 443286
e-mail: info@wavin.co.uk
website: www.wavin.co.uk

**Agrément
Certificate
No 86/1643**
Second issue*

Designated by Government
to issue
European Technical
Approvals

OSMAVENT 110 AND OSMAVENT 40 AIR ADMITTANCE VALVES

Clapets d'admission d'air pour systèmes d'évacuation
Belüftungsventile für Entwässerungssysteme

Product

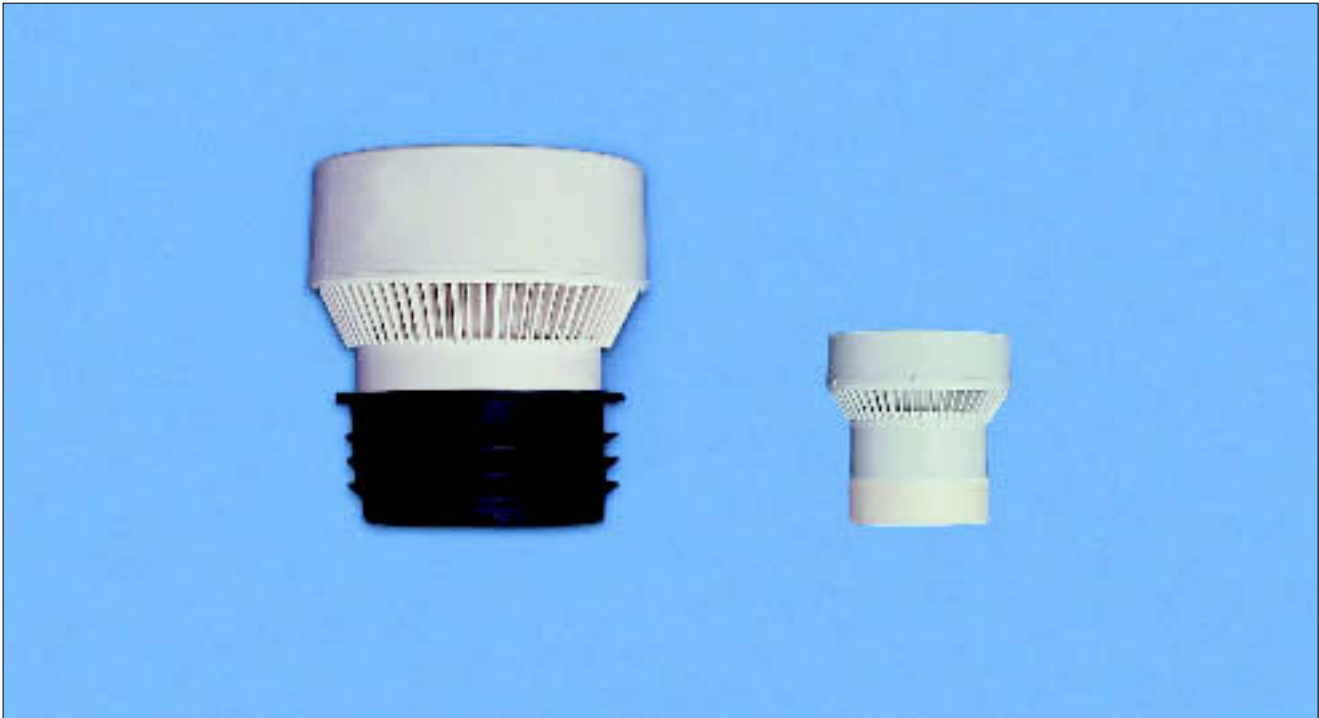

• THIS CERTIFICATE REPLACES
CERTIFICATE No 84/1333
AND RELATES TO
OSMAVENT 110 AND
OSMAVENT 40 AIR
ADMITTANCE VALVES FOR
ABOVE GROUND DRAINAGE
SYSTEMS.

• The valves are for use within
buildings in above ground
drainage systems designed in
accordance with this Certificate
and are designation A1 rating
in accordance to
BS EN 12380 : 2002.

• The valves provide a means
of ventilation to the drainage
system to prevent the loss of
water seals in traps and
consequent release of foul air
into the building.

Regulations

1 The Building Regulations 2000 (as amended) (England and Wales)

 The Secretary of State has agreed with the British Board of Agrément the requirements of the Building Regulations to which air admittance valves can contribute in achieving compliance. In the opinion of the BBA, OsmaVent 110 and OsmaVent 40 Air Admittance Valves, used in accordance with the provisions of this Certificate, will contribute to meeting the relevant requirements.

Requirement: H1
Comment:

Foul water drainage

OsmaVent Valves will:

- (1) provide adequate ventilation to prevent the loss of water seals in trapped appliances. See sections 7.1 to 7.4, 8.1 to 8.9 and 9.1 to 9.3 of this Certificate.
- (2) prevent foul air from entering the building. See section 9.2 of this Certificate.
- (3) enable access to the sanitary pipework for clearing blockages. See section 8.1 of this Certificate.
- (4) contribute to the ventilation of underground drains. See sections 8.2 and 8.3 of this Certificate.

Requirement: Regulation 7
Comment:

Materials and workmanship

The products are acceptable. See section 11 of this Certificate.

continued

Electronic Copy

continued

- The drainage systems and the installation and use of the valves must be in accordance with the conditions set out in the Design Data and Installation parts of this Certificate.

2 The Building Standards (Scotland) Regulations (1990 as amended)



In the opinion of the BBA, OsmaVent 110 and OsmaVent 40 Air Admittance Valves, if used in accordance with the provisions of this Certificate, will satisfy the various Regulations and related Technical Standards as listed below.

Regulation:	10	Fitness of materials and workmanship
Standard:	B2.1	Selection and use of materials, fittings, and components, and workmanship
Comment:		The products can contribute to a construction meeting this Standard. See the <i>Installation</i> part of this Certificate.
Standard:	B2.2	Selection and use of materials, fittings, and components, and workmanship
Comment:		The product is an acceptable material. See section 11 of this Certificate.
Regulation:	24	Drainage
Standard:	M2.2	Drainage system — Wastewater and surface water drainage
Comment:		The valves can meet the relevant requirements of this Standard. See sections 7.1 to 7.4, 8.1 to 8.4, 8.6 to 8.9 and 9.1 to 9.3 of this Certificate.

3 The Building Regulations (Northern Ireland) 2000



In the opinion of the BBA, OsmaVent 110 and OsmaVent 40 Air Admittance Valves, if used in accordance with the provisions of this Certificate, will satisfy the various Building Regulations as listed below.

Regulation:	B2	Fitness of materials and workmanship
Comment:		The products are acceptable. See section 11 of this Certificate.
Regulation:	N2	Drainage systems
Comment:		The valves provide adequate ventilation to prevent the destruction of the water seals in traps. See sections 7.1 to 7.4, 8.1 to 8.4, 8.6 to 8.9 and 9.1 to 9.3 of this Certificate.

4 Construction (Design and Management) Regulations 1994 (as amended)

Construction (Design and Management) Regulations (Northern Ireland) 1995 (as amended)

In the opinion of the BBA there is no information in this Certificate which relates to the obligations of the client, planning supervisor, designer and contractors under these Regulations.

Technical Specification

5 Description

5.1 The OsmaVent 110 valve (see Figure 1) comprises three acrylonitrile-butadiene-styrene (ABS) components (upper body, lower body and diaphragm body with integrally-moulded protection screens), the two synthetic rubber components (diaphragm and connector). The synthetic rubber connector allows push-fitting into 110 mm diameter PVC-U soil pipe in accordance with BS 4514 : 2001 and BS EN 1329-1 : 2000 (see Table 1). With the connector, the valve fits 110 mm diameter pipe. Without the connector, the valve fits 82 mm diameter pipe by solvent welding with Osma Solvent Cement No 2.

5.2 The OsmaVent 40 valve (see Figure 2) comprises three plastic components to a specification agreed by the BBA (cap, diaphragm carrier and lower body with integrally-moulded insect screens), and a synthetic rubber diaphragm and connector. The cap and lower body are joined together. The connector allows push-fitting onto waste pipes, with sizes as given in Table 1.

5.3 The valves are designation A1 rating to BS EN 12380 : 2002.

5.4 An expanded polystyrene insulation cover is supplied with each OsmaVent 110 and OsmaVent 40 valve as a protection against extreme high and low temperatures.

5.5 Continuous quality control is exercised during manufacture and assembly, including visual checks, checks on dimensional accuracy and airtightness. The raw materials and bought in goods are subject to quality control checks.

Table 1 Waste pipe dimensions (in mm) for use with OsmaVent valves

Nominal size	Minimum mean OD	Maximum mean OD	Minimum wall thickness	Maximum wall thickness	Corresponding reference ⁽¹⁾
<i>OsmaVent 110</i>					
110	110.00	110.30	3.2	3.8	BS 4514/ BS EN 1329-1
<i>OsmaVent 40</i>					
34	34.40	34.80	1.8	2.2	BS EN 1451-1
41	40.80	41.20	1.9	2.3	
54	53.90	54.30	2.0	2.4	BS 5255
32	36.15	36.45	1.8	2.2	
40	42.75	43.05	1.9	2.3	
50	55.75	56.05	2.0	2.4	

(1) These documents are detailed in the *Bibliography*.

6 Delivery and site handling

6.1 OsmaVent 110 and OsmaVent 40 valves are shrink-wrapped and packaged in expanded polystyrene boxes which may be used as a cover (see section 5.3 of this Certificate).

6.2 The manufacturer's legend *OsmaVent 110* or *OsmaVent 40* is printed appropriately on each valve cap and shown on the packaging. In addition, both valves have CE mark designation A1 to BS EN 12380 : 2002 and the last two digits of manufacture printed on the valve.

6.3 A label bearing the BBA identification mark incorporating the number of this Certificate is printed on each valve.

Electronic Copy

Figure 1 OsmaVent 110 air admittance valve

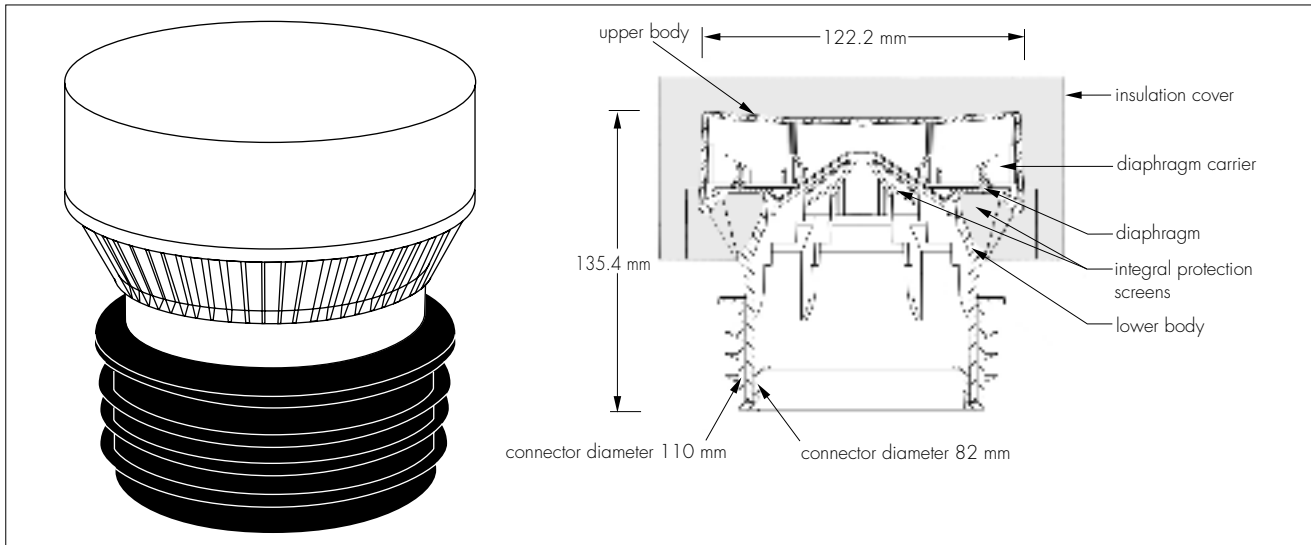
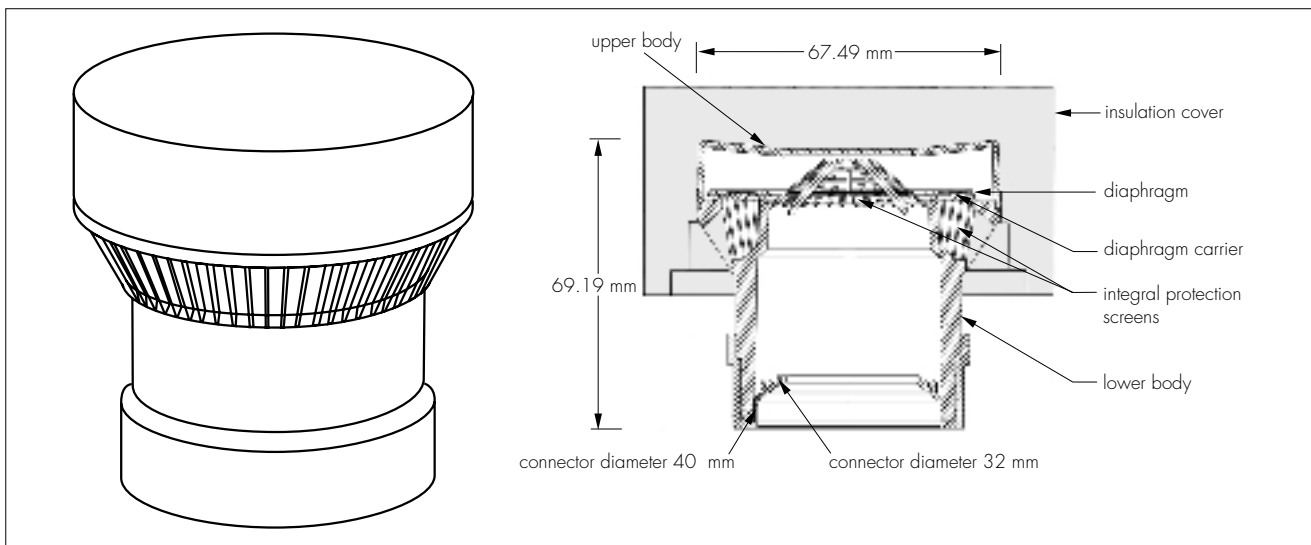

Figure 2 OsmaVent 40 air admittance valve



Design Data

7 General

7.1 When used in above-ground drainage systems designed in accordance with BS EN 12056-1 : 2000 and BS EN 12056-2 : 2000 the valves:

- admit air under conditions of reduced pressure in the discharge pipes and prevent water seals in traps from being drawn
- prevent the release of foul air from the drainage system
- contribute to the ventilation of the main drain to which the discharge stack incorporating the valve is connected.

7.2 The OsmaVent 40 valve is for use on branch discharge stacks.

7.3 The OsmaVent 110 valve is for use on discharge stacks up to 45 metres or 10 storeys high.

7.4 The OsmaVent 110 and OsmaVent 40 valves are for use in association with each other or separately.

8 Drainage system design

8.1 Drainage systems designed in accordance with BS EN 12056-1 : 2000 and BS EN 12056-2 : 2000 should be based on the airflow data given in Table 2. Typical installation details in accordance with BS EN 12056-1 : 2000 are given in Figures 3 and 4.

Table 2 Airflow performance⁽¹⁾ (litres per sec)

Nominal size of pipe (mm)	OsmaVent 40	OsmaVent 110
40	7.3 ⁽²⁾	—
110	—	32.5 ⁽³⁾

(1) These results are based on tests carried out by the Belgian Building Research Institute in accordance with BS EN 12380 : 2002.

(2) Calculated from a test value of 7.7 l s⁻² for 50 mm pipe.

(3) Test value for 100 mm pipe.

8.2 To contribute to the ventilation of the underground drain and to minimise the effects of excessive back pressures when a drain blockage

occurs, the branch or main drain serving a stack or stacks fitted with OsmaVent valves may require venting at a point upstream of the stack connection. For guidance the following should be noted (see Figure 5):

- For up to and including four dwellings, one, two or three storeys in height, additional drain venting is not required. Where a drain serves more than four such dwellings equipped with the valve the drain should be vented according to the following rule, either by a conventional open-topped ventilation or discharge stack:
 - 5 to 10 such dwellings — conventional ventilation to be provided at the vent stack closest to the main drain sewer
 - 11 to 20 such dwellings — conventional ventilation to be provided at the vent closest to the main drain sewer and at the mid-point of the system.
- For multi-storey domestic dwellings (other than those referred to above) and non-domestic buildings, conventional drain venting should be provided if more than one such building, each equipped with the valves, is connected to a common drain which is not itself vented by means of a ventilation stack or a discharge stack not fitted with a valve.

8.3 To prevent self-siphonage a connection to the OsmaVent 40 valve is required within 1500 mm of the trap (see Figure 4).

8.4 To prevent induced siphonage in a row of wash-basins, an OsmaVent 40 valve should be fitted between the two wash-basins furthest from the discharge stack (see Figure 4).



8.5 Air admittance valves should not be used as the only ventilation to a drainage system discharging to septic tanks or cesspools.



8.6 The valve should be installed within the building where it is easily accessible but not subject to interference by vandals.

8.7 If the valve is to be installed in, or in close proximity to, a habitable space where noise of operation may cause a nuisance, then consideration must be given to the use of a suitable form of sound insulation.

8.8 In installations other than those shown in Figure 5, stacks should not be fitted with the valves when the connecting drain(s) are subject to periodic surcharging or are fitted with intercepting traps. An open-topped discharge stack or ventilating stack should be used in such cases.

8.9 The insulation cover should be used when there is a possibility that the valve may be exposed to extreme high or low temperatures.

9 Effect on water seals



9.1 The valves will admit sufficient quantities of air into the stack when they are subjected to a reduced pressure and thereby prevent loss of the water seals in appliance traps.

9.2 Under conditions of increased pressure in the drainage system, each valve will remain closed, thereby preventing the release of foul air into the building.

9.3 A pressure increase sufficient to raise the level in the water seal or to cause foul air to bubble up through the seal is an indication that a drain blockage has occurred or that the system is being overloaded or otherwise misused.

10 Maintenance

10.1 OsmaVent 110 and OsmaVent 40 valves do not normally require maintenance.

10.2 In the event of accidental damage or vandalism the OsmaVent 110 and OsmaVent 40 valves must be renewed.

11 Durability



OsmaVent valves are manufactured from materials conventional in drainage systems. Repeated opening and closing will not adversely affect the sealing or operation of the valve. When used in the context of this Certificate the product will not be subject to significant deterioration and will have a life equivalent to that of the drainage system in which it is installed.

Installation

12 Procedure

12.1 Installation must be carried out in accordance with the Certificate holder's instructions.

12.2 OsmaVent 110 valves are supplied with a synthetic rubber connector (diameter 75 mm) enabling a push-fit into 110 mm PVC-U pipes to BS 4514 : 2001 and BS EN 1329-1 : 2000.

12.3 OsmaVent 110 valves must be fitted in a vertical position 200 mm above the highest branch connection (see Figure 3).

12.4 OsmaVent 40 valves push-fit onto 40 mm or 32 mm diameter pipes to BS 5255 : 1989, BS EN 1451-1 : 2000 and BS EN 12056-2 : 2000. For 32 mm diameter pipe fitting, the valve is installed directly onto the deburred pipe. For 40 mm diameter pipe fitting, the connector is removed from the base of the valve and the inner part of the connector removed. The pipe is cut square and burrs removed. The connector is pushed onto the pipe by about 50 mm, the valve held on top of the pipe and the connector pushed up over the valve to secure it.

12.5 OsmaVent 40 valves must be fitted in a vertical position 100 mm above the pipe being ventilated (see Figure 4).

12.6 The valves are easily installed in discharge and/or ventilation pipes and obviate the need to penetrate the roof covering. Care should be taken to avoid contamination of the sealing surfaces, as this may affect airtightness.

Figure 3 Valves installed in domestic dwellings

(a) ventilated by OsmaVent 110 valve

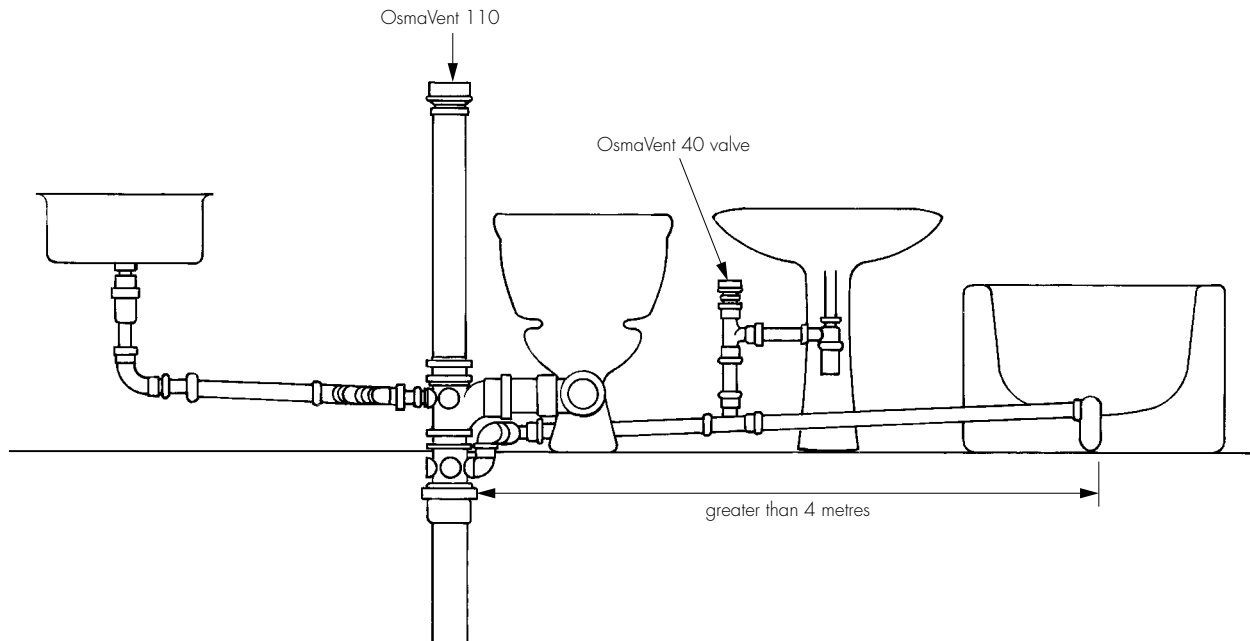

(b) unventilated

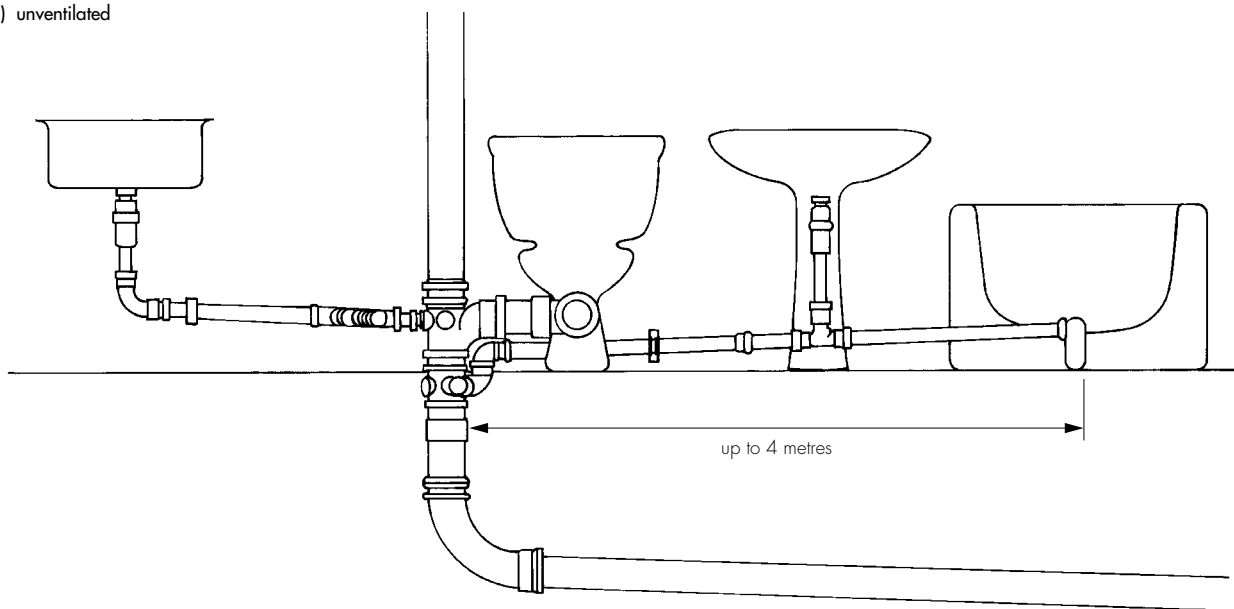

NOTES:

- The maximum distance of appliance traps from the discharge stack must be in accordance with BS EN 12056-2 : 2000, paragraph 6.4.3, Table 10 and Figure 9 *Ventilated branches*. The separate ventilation shown on the BS figures may be provided by an OsmaVent 40 valve which must be within 1.5 metres of the appliance trap.
- Unventilated branches BS EN 12056-2 : 2000, paragraph 6.4.11, Table 5 and Figure 6.
- Ventilated stacks higher than 45 metres or 10 storeys must not be fitted with the OsmaVent 110 valve.

Electronic Copy

Figure 4 Installation

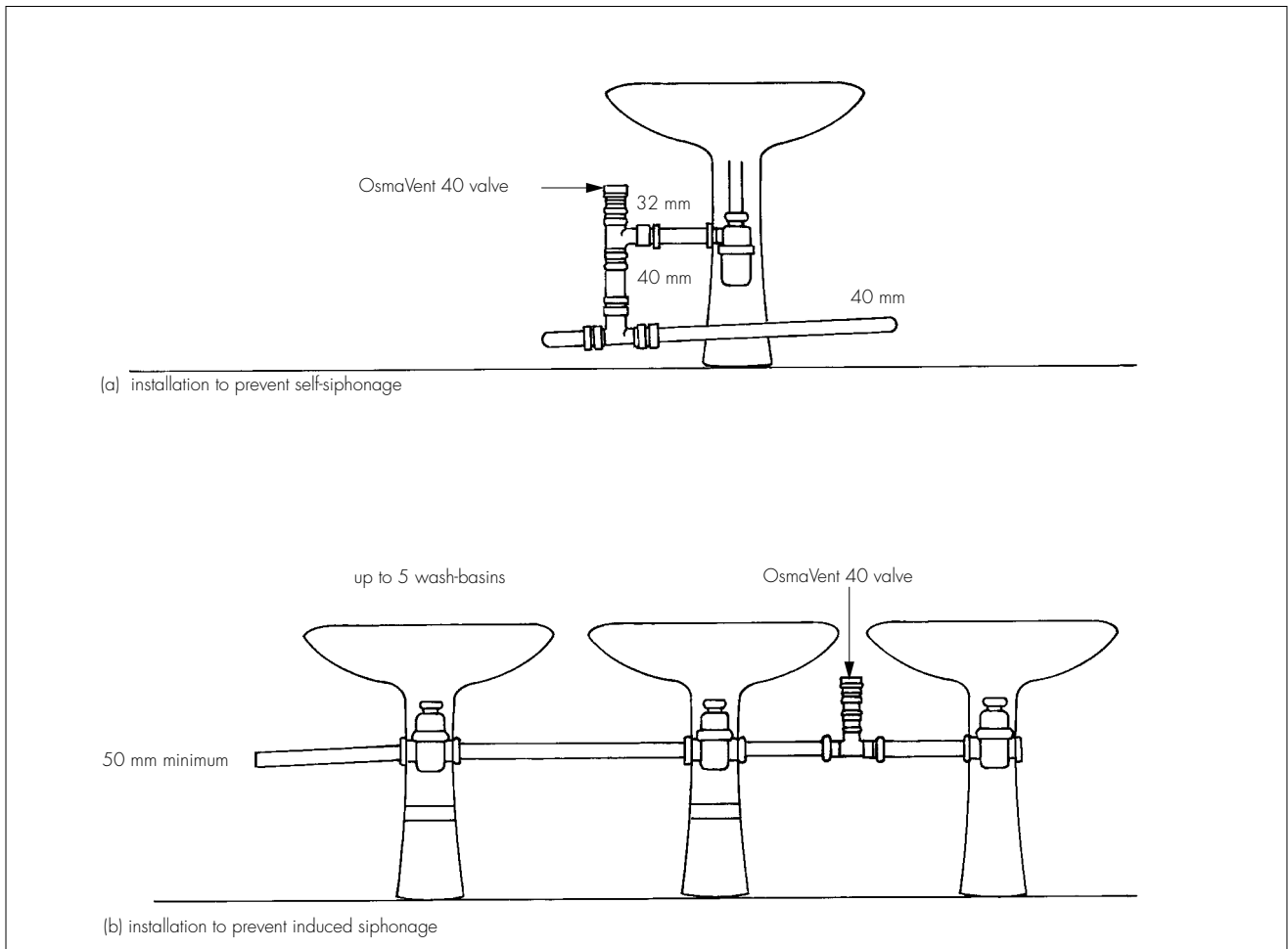
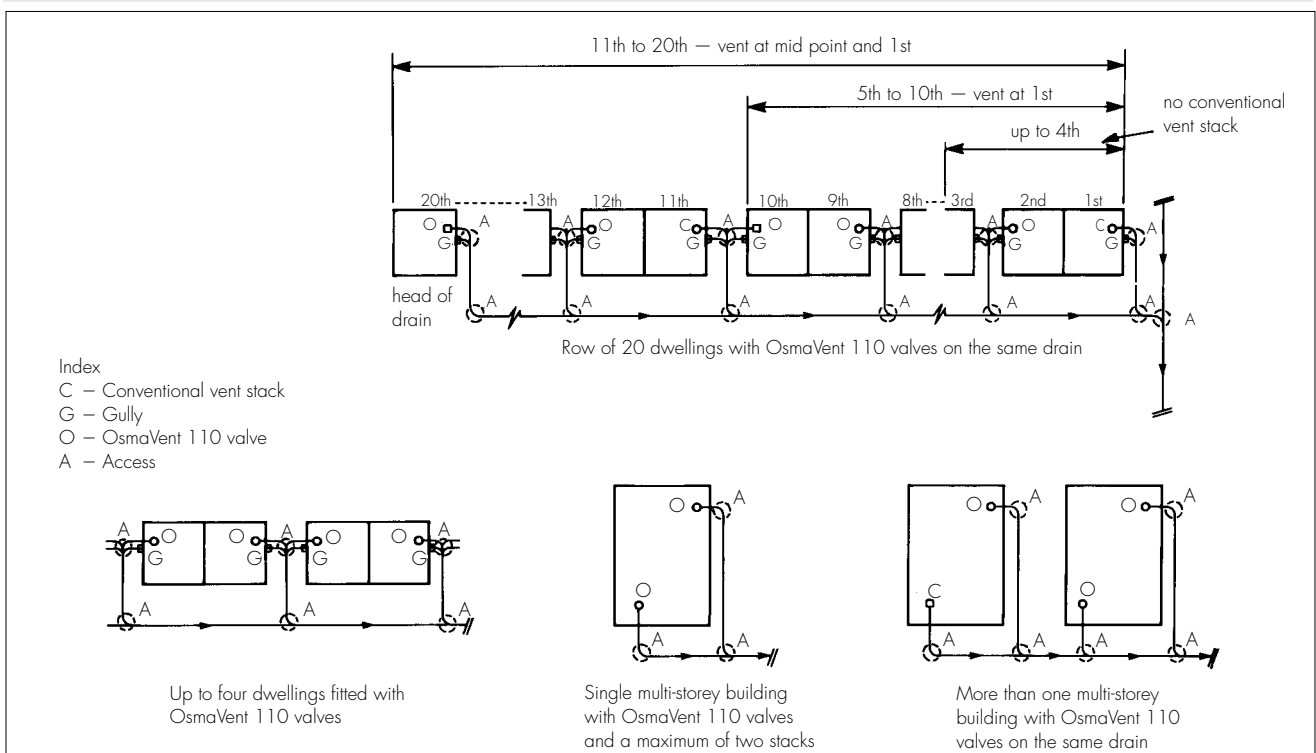

Figure 5 Examples of drain ventilation provisions



- NOTES:
- Access arrangements shown are indicative only and may be varied to suit particular system layouts.
 - The underground drain must be designed in accordance with BS EN 752-1 : 1996, BS EN 752-2 : 1997, BS EN 752-3 : 1997, BS EN 752-4 : 1998.
 - If the branch drain is fitted with an intercepting trap before the connection to the main drain/sewer then a conventional open-topped ventilation discharge stack must be provided at the nearest point upstream of the intercepting trap.

Technical Investigations

The following is a summary of the technical investigations carried out on the OsmaVent 110 and OsmaVent 40 Air Admittance Valves.

13 Tests

13.1 As part of the assessment resulting in the issue of the previous Certificate No 84/1333, tests were carried out to determine:

- effect of pressure cycling
- performance in use on a stack when tested in accordance with BS 5572 : 1994⁽¹⁾
- airtightness under normal operating conditions
- airtightness after ageing synthetic rubber connectors
- watertightness under positive pressure
- Shore hardness of the diaphragm seals
- dimensional checks
- practicability of installation.

(1) Existing systems only.

13.2 Tests were conducted to determine the performance in use for the conditions covered in the *Design Data* part of this Certificate.

13.3 Tests were carried out on the OsmaVent 110 and OsmaVent 40 Air Admittance Valves to establish:

- impact drop tested and correct functioning
- airtightness when tested to a pressure of 3 mm, 50 mm and 1000 mm water gauge
- airtightness under normal conditions
- reduced pressure to open
- airtightness after ageing connector
- Shore hardness of diaphragm.

13.4 Tests were carried out on OsmaVent 110 and OsmaVent 40 Air Admittance Valves in accordance with BS EN 12380 : 2002:

- drop test
- airtightness after endurance at negative temperature
- airtightness before and after endurance at positive temperature
- opening pressure
- airflow capacity
- peak discharge flow simulation.

14 Investigations

14.1 The manufacturing process was examined including the methods adopted for quality control and details were obtained of the quality and composition of materials used.

14.2 A re-examination was made of the data on which the previous Certificates were based. The conclusions drawn from the original data remain valid.

14.3 Data in relation to the following were examined:

- effect on trap seals when tested on five-storey test rigs
- self and induced siphonage
- stress relaxation
- creep durability.

14.4 Regular factory inspections have been carried out to ensure that quality is being maintained.

14.5 A user survey has been carried out to confirm performance in use.

14.6 An evaluation was made of the Belgian Building Research Institute report on OsmaVent valves.

Bibliography

BS 4514 : 2001 *Unplasticized PVC soil and ventilating pipes of 82.4 mm minimum mean, outside diameter and fittings and accessories of 82.4 mm and of other sizes — specification*

BS 5255 : 1989 *Specification for thermoplastics waste pipe and fittings*

BS 5572 : 1994 *Code of practice for sanitary pipework*

BS EN 752-1 : 1996 *Drain and sewer systems outside buildings — Generalities and definitions*

BS EN 752-2 : 1997 *Drain and sewer systems outside buildings — Performance requirements*

BS EN 752-3 : 1997 *Drain and sewer systems outside buildings — Planning*

BS EN 752-4 : 1998 *Drain and sewer systems outside buildings — Hydraulic design and environmental considerations*

BS EN 1329-1 : 2000 *Plastics piping systems for soil and waste discharge (low and high temperature) within the building structure — Unplasticized poly(vinyl chloride) (PVC-U)*

BS EN 1451-1 : 2000 *Plastics piping systems for soil and waste discharge (low and high temperature) within the building structure — Polypropylene (PP) — Specifications for pipes, fittings and the system*

BS EN 12056-1 : 2000 *Gravity Drainage Systems inside Buildings — General and performance requirements*

BS EN 12056-2 : 2000 *Gravity Drainage Systems inside Buildings — Sanitary pipework, layout and calculation*

BS EN 12380 : 2002 *Air admittance valves for drainage systems — Requirements, test methods and evaluation of conformity*

Conditions of Certification

15 Conditions

15.1 This Certificate:

- (a) relates only to the product that is named, described, installed, used and maintained as set out in this Certificate;
- (b) is granted only to the company, firm or person identified on the front cover — no other company, firm or person may hold or claim any entitlement to this Certificate;
- (c) is valid only within the UK;
- (d) has to be read, considered and used as a whole document — it may be misleading and will be incomplete to be selective;
- (e) is copyright of the BBA;
- (f) is subject to English law.

15.2 References in this Certificate to any Act of Parliament, Regulation made thereunder, Directive or Regulation of the European Union, Statutory Instrument, Code of Practice, British Standard, manufacturers' instructions or similar publication, are references to such publication in the form in which it was current at the date of this Certificate.

15.3 This Certificate will remain valid for an unlimited period provided that the product and the manufacture and/or fabrication including all related and relevant processes thereof:

- (a) are maintained at or above the levels which have been assessed and found to be satisfactory by the BBA;

(b) continue to be checked as and when deemed appropriate by the BBA under arrangements that it will determine; and

(c) are reviewed by the BBA as and when it considers appropriate.

15.4 In granting this Certificate, the BBA is not responsible for:

- (a) the presence or absence of any patent, intellectual property or similar rights subsisting in the product or any other product;
- (b) the right of the Certificate holder to market, supply, install or maintain the product; and
- (c) the actual works in which the product is installed, used and maintained, including the nature, design, methods and workmanship of such works.

15.5 Any recommendations relating to the use or installation of this product which are contained or referred to in this Certificate are the minimum standards required to be met when the product is used. They do not purport in any way to restate the requirements of the Health & Safety at Work etc Act 1974, or of any other statutory, common law or other duty which may exist at the date of this Certificate or in the future; nor is conformity with such recommendations to be taken as satisfying the requirements of the 1974 Act or of any present or future statutory, common law or other duty of care. In granting this Certificate, the BBA does not accept responsibility to any person or body for any loss or damage, including personal injury, arising as a direct or indirect result of the installation and use of this product.



In the opinion of the British Board of Agrément, OsmaVent 110 and OsmaVent 40 Air Admittance Valves are fit for their intended use provided they are installed, used and maintained as set out in this Certificate. Certificate No 86/1643 is accordingly awarded to Wavin Plastics Limited.

On behalf of the British Board of Agrément

Date of Second issue: 18th April 2005

Chief Executive

**Original Certificate issued 16th June 1986. This amended version includes change of Certificate holder's name, extended product range, a limitation of stack height with the OsmaVent 110 valve, clarification of provision of conventional ventilation, reference to revised Building Regulations and Standards, addition of CDM Regulations and Bibliography, and new Conditions of Certification.*