

CEP Claddings Limited

Wainwright Close
Churchfields
Hastings
East Sussex TN38 9PP
Tel: 01424 852641 Fax: 01424 852797
e-mail: claddings@cepgroup.co.uk
website: www.cepgroup.co.uk



Agrément Certificate
86/1787
Product Sheet 1

CEP CLADDING PRODUCTS

PETRARCH EXTERNAL SHEETING

PRODUCT SCOPE AND SUMMARY OF CERTIFICATE

This Certificate relates to Petrarch External Sheeting, for use externally as a decorative and protective vertical cladding or infill panelling, or internally as decorative panelling. The sheets are constituted from marble and stone fillers, polyester resin binder and glassfibre reinforcement.

AGRÉMENT CERTIFICATION INCLUDES:

- factors relating to compliance with Building Regulations where applicable
- factors relating to additional non-regulatory information where applicable
- independently verified technical specification
- assessment criteria and technical investigations
- design considerations
- installation guidance
- regular surveillance of production
- formal three-yearly review.



KEY FACTORS ASSESSED

Strength and stability — when installed in accordance with this Certificate and the Certificate holder's instructions, the product will have adequate strength to resist the wind loads and impacts likely to occur under normal circumstances (see section 5).

Behaviour in relation to fire — the product is not classified as 'non-combustible', but achieves a Class 0 or 'low risk' classification as defined in the national Building Regulations (see section 6).

Weathertightness — the product has adequate resistance to the passage of moisture (see section 7).

Durability — the product is durable and can be expected to have a service life in excess of 30 years (see section 9).

The BBA has awarded this Agrément Certificate to the company named above for the product described herein. The product has been assessed by the BBA as being fit for its intended use provided it is installed, used and maintained as set out in this Certificate.

On behalf of the British Board of Agrément

A handwritten signature in black ink, appearing to read 'Simon Wroe'.

Simon Wroe
Head of Approvals — Materials

A handwritten signature in black ink, appearing to read 'Greg Cooper'.

Greg Cooper
Chief Executive

Date of First issue: 11 January 2012

Originally certificated on 13 March 1987

The BBA is a UKAS accredited certification body — Number 113. The schedule of the current scope of accreditation for product certification is available in pdf format via the UKAS link on the BBA website at www.bbacerts.co.uk

Readers are advised to check the validity and latest issue number of this Agrément Certificate by either referring to the BBA website or contacting the BBA direct.

British Board of Agrément
Bucknalls Lane
Garston, Watford
Herts WD25 9BA

©2012

tel: 01923 665300
fax: 01923 665301
e-mail: mail@bba.star.co.uk
website: www.bbacerts.co.uk

Regulations

In the opinion of the BBA, Petrarch External Sheeting, if used in accordance with the provisions of this Certificate, will meet or contribute to meeting the relevant requirements of the following Building Regulations:



The Building Regulations 2010 (England and Wales)

Requirement: A1	Loading
Comment:	Buildings clad with the product will meet this Requirement where the sheeting is fixed to suitably designed sub-frames and walls. See section 5.1 of this Certificate.
Requirement: B2(1)	Internal fire spread (linings)
Requirement: B4(1)	External fire spread
Comment:	The product is unrestricted under these Requirements. See section 6 of this Certificate.
Requirement: C2(b)	Resistance to moisture
Comment:	The product can contribute to meeting this Requirement. See section 7 of this Certificate.
Requirement: Regulation 7	Materials and workmanship
Comment:	The product is acceptable. See section 9.1 and the <i>Installation</i> part of this Certificate.



The Building (Scotland) Regulations 2004 (as amended)

Regulation: 8(1)(2)	Fitness and durability of materials and workmanship
Comment:	The product is acceptable. See sections 8.1, 8.2, 9.1 and the <i>Installation</i> part of this Certificate.
Regulation: 9	Building standards – construction
Standard: 1.1(a)(b)	Structure
Comment:	Buildings clad with the product will meet the requirement where the sheeting is fixed to suitably designed sub-frames and walls. See section 5.1 of this Certificate.
Standard: 2.5	Internal linings
Comment:	The product can contribute to satisfying this Standard, with reference to clause 2.5 ⁽¹⁾⁽²⁾ . See section 6 of this Certificate.
Standard: 2.6	Spread to neighbouring buildings
Standard: 2.7	Spread on external walls
Comment:	The product is not classified as ‘non-combustible’ and is therefore restricted under these Standards, with reference to clauses 2.6.4 ⁽¹⁾⁽²⁾ and 2.7.1 ⁽¹⁾⁽²⁾ . See section 6 of this Certificate.
Standard: 3.10	Precipitation
Comment:	The product can contribute to meeting this Standard, with reference to clauses 3.10.1 ⁽¹⁾⁽²⁾ to 3.10.3 ⁽¹⁾⁽²⁾ . See section 7 of this Certificate.
Standard: 7.1(a)	Statement of sustainability
Comment:	The product can contribute to meeting the relevant requirements of Regulation 9, Standards 1 to 6 and therefore will contribute to a construction meeting a bronze level of sustainability as defined in this Standard.
Regulation: 12	Building standards – construction
	Comments made in relation to this product under Regulation 9, Standards 1 to 6 also apply to this Regulation, with reference to clause 0.12.1 ⁽¹⁾⁽²⁾ and Schedule 6 ⁽¹⁾⁽²⁾ .
	(1) Technical Handbook (Domestic).
	(2) Technical Handbook (Non-Domestic).



The Building Regulations (Northern Ireland) 2000 (as amended)

Regulation: B2	Fitness of materials and workmanship
Comment:	The product is acceptable. See section 9.1 and the <i>Installation</i> part of this Certificate.
Regulation: B3(2)	Suitability of certain materials
Comment:	The product is acceptable. See sections 8.1 and 8.2 of this Certificate.
Regulation: C4(b)	Resistance to ground moisture and weather
Comment:	The product will provide a weatherproof barrier when installed in accordance with section 7 of this Certificate.
Regulation: D1	Stability
Comment:	Buildings clad with the product will meet this Regulation where the sheeting is fixed to suitably designed sub-frames and walls. See section 5.1 of this Certificate.
Regulation: E3(a)(b)	Internal fire spread – Linings
Regulation: E5(a)(b)	External fire spread
Comment:	The product is unrestricted under these Regulations. See section 6 of this Certificate.

Construction (Design and Management) Regulations 2007

Construction (Design and Management) Regulations (Northern Ireland) 2007

Information in this Certificate may assist the client, CDM co-ordinator, designer and contractors to address their obligations under these Regulations.

See sections: 2 *Delivery and site handling* (2.2) and 3 *General* (3.5) of this Certificate.

NHBC Standards 2011

NHBC accepts the use of Petrarch External Sheeting, when installed and used in accordance with this Certificate, in relation to *NHBC Standards, Part 6 Superstructure (excluding roofs) Chapter 6.2 External timber framed walls*, and *Chapter 6.9 Curtain walling and cladding*.

Technical Specification

1 Description

1.1 Petrarch External Sheeting consists of marble and natural stone fillers with a polyester resin binder and glassfibre reinforcement. Four types of sheet are available, as follows:

- Standard Riven — textured on the exposed surface and smooth on the reverse
- Riven Matt — as Standard Riven but with the exposed surface shot blasted
- Standard Smooth⁽¹⁾ — smooth on both the exposed and reverse sides
- Smooth Matt — as Standard Smooth but with the exposed surface shot blasted.

(1) A smooth honed finish is also available which is polished on the exposed surface, but only in 10 mm thickness and with a maximum width of 989 mm.

1.2 The sheets can be supplied cut to size, pre-drilled with edges bevelled, rebated and polished. The sheets are available in the standard sizes and weights and colours given in Tables 1 and 2.

Table 1 Sheet sizes and weights⁽¹⁾

Size (mm)	Thickness (mm)	Weight (kg·m ⁻²)
3000 x 1200	7	15.7
	10	22.0
2400 x 1200	7	15.7
	10	22.0

(1) Pre-cut sheets are available within the standard sheet sizes.

Table 2 Standard colours⁽¹⁾

Colour	Ref no	Colour	Ref no
Alabaster	010	Light Stone	009
Aluminium	672	Limestone	012
Ash	023	Mocha	022
Dorset	519	Parchment	011
Dover	026	Pewter	247
Graphite	003	Russet	598
Heather	002	Rye	025
Jade	001	Salmon	024

(1) Other colours are available by special order from the Certificate holder.

1.4 Petrarch sheeting has a nominal flexural strength of 25 MPa and flexural modulus of 11,000 MPa.

1.5 Petrarch sheeting is normally supplied unbacked. Sheets lined with conventional insulation materials and framed panels are available, but these have not been assessed by the BBA and are outside the scope of this Certificate.

1.6 During manufacture the basic constituents, comprising fillers, resin and glassfibre strands are weighed and thoroughly mixed into a dough. The dough is levelled and compressed to a standard width and thickness. Standard lengths are cut, transferred to a mould and heat-cured under pressure.

1.7 Ancillary components used with the sheets are:

- Torx screws — dome-headed, stainless steel, 4.8 mm diameter used in timber stud applications
- rivets — 5 mm diameter stainless steel, used in aluminium stud applications
- support brackets/rails — used in aluminium stud applications to provide support to the sheets and include; F1.40 wall brackets, horizontal C profile, vertical T profile, standard and adjustable panel hangers, Z-section and pre-fabricated corner profiles
- proprietary joint details — used between sheets to ensure weathertightness/gap uniformity and include; bird beak profile section, top hat, chair section, EPDM joint strip and solvent-free sealant.

1.8 Quality control is exercised over raw materials, during manufacture, and on the final product.

2 Delivery and site handling

2.1 Sheets are delivered to site packed on pallets and separated by soft foam. Packs of sheets are wrapped in plastic sheeting bearing the manufacturer's name and the BBA identification mark incorporating the number of this Certificate.

2.2 Pallets must be raised clear of the ground and laid on a flat base. The polythene sheet must be replaced, as individual sheets of Petrarch are removed, to protect the remaining sheets from surface damage or contamination by cement, or other materials, which may affect their appearance. Pallets must not be stacked more than two high.

2.3 Individual sheets should be carried on edge and handled with care.

Assessment and Technical Investigations

The following is a summary of the assessment and technical investigations carried out on Petrarch External Sheeting.

Design Considerations

3 General

3.1 Petrarch External Sheeting is satisfactory for use externally as a decorative and protective vertical cladding or infill panelling, or internally as decorative panelling.

3.2 When used as cladding, the sheets are normally fixed to a sub-frame of timber or aluminium studding, which should be designed taking into account the likely loads to be imposed on the structure during its service life. Guidance on the design of sub-frames can be found in the following documents, but the design and installation of individual sub-frames is outside the scope of this Certificate:

- timber studwork — should be preservative-treated, and constructed in accordance with BS EN 1995-1-1 : 2004 and the UK National Annex. Studs should be at 600 mm centres or less in exposed locations
- aluminium studwork — the guidance given in BS EN 1999-1-1 : 2007 and the UK National Annex must be taken into account.

3.3 For relevant timber-frame constructions, attention is drawn to the NHBC requirement given in Chapter 6.2 — D4(c) that a 15 mm wide ventilated cavity be maintained between claddings and sheathings. In this case the joints between the panels are sealed.

3.4 For rainscreen constructions, attention is drawn to the NHBC requirement given in Chapter 6.9 — D8(b) that a 50 mm wide ventilated cavity be maintained between the cladding and sheathings.

3.5 Sheets larger than 1200 mm by 600 mm used as infill panels require additional support as described in section 3.2.

3.6 The product can be cut using a masonry cutting disc and drilled using tungsten-carbide tipped masonry drills. Where there is a risk of dust inhalation, reference should be made to HSE Guidance Note EH44/2005 *Dust : General principles of protection*, and operatives should wear appropriate personal protective equipment.

3.7 The coefficient of expansion per degree centigrade for the product is 22×10^{-6} . A temperature change of 40°C will produce a movement of 2.64 mm in a 3 m length of 7 mm thick sheet, and the surface temperature of dark coloured sheet may achieve 60°C or more when exposed to full sunlight. Therefore suitable expansion gaps must be left between panels and fixing holes must be oversized to allow for thermal movement, in accordance with the Certificate holder's instructions (see sections 11.1 and 11.3).

3.8 Joints can be waterproofed by means of a neoprene gasket at the joint positions, or by the application of a durable sealant between the panels. Typical joint details are shown in *Installation* part of this Certificate. Where sealant joints are likely to be damaged (such as at low level, or in areas prone to vandalism), the use of neoprene gaskets is recommended.

4 Practicability of installation

The product should be installed by cladding contractors experienced with this type of product.

5 Strength and stability

Wind loading



5.1 When fixed in accordance with this Certificate, the product will withstand the pressures imposed by the wind forces likely to be experienced in the UK without damage or permanent deflection. However, in exposed locations where high wind loads may be anticipated, the spacing of stud members should be decreased in accordance with the advice of the Certificate holder.

Impact

5.2 The product has adequate resistance to impact for use in the locations described in Table 3. Impact resistance can be improved by either backing the sheet or decreasing the centres of the studwork.

Table 3 Access categories

Category	Description	Examples	
(1)	(2)		
B	E ₂	Readily accessible to public and others with little incentive to exercise care. Chance of accidents occurring and of misuse	} Zone of wall up to 1.5 m above pedestrian or floor level
C	E ₃	Accessible primarily to those with some incentive to exercise care. Some chance of accident occurring and of misuse	
D	E ₄	Only accessible, but not near a common route, to those with high incentive to exercise care. Small chance of accident occurring or of misuse	
E	E' ₂	Above zone of normal impacts from people but liable to impacts from thrown or kicked objects	
F	E ₅	Above zone of normal impacts from people and not liable to those impacts from thrown or kicked objects	

(1) BS 8200 : 1985 (withdrawn)

(2) MOAT 43 : 1987

5.3 When subjected to exceptional impacts the product will tend to fracture under the point of impact without fragmenting.

6 Behaviour in relation to fire



Samples of the product, when tested to BS 476-6 : 1989, achieved an index of performance (I) of less than 12 with sub-index (i_1) of less than 6, and when tested to BS 476-7 : 1997 achieved a Class 1 surface. The product therefore has a Class 0 or 'low risk' surface as defined in the various Building Regulations.

7 Weathertightness



The product, when incorporated into a cladding system designed and installed in accordance with the Certificate holder's instructions and conventional good practice, will adequately resist the passage of moisture.

8 Maintenance



8.1 Maintenance will not normally be required but, when necessary, stains or marks can be removed with a damp cloth and household detergent, or, in the case of obstinate stains, mild abrasive cleaner. Where paint, varnish or similar materials are to be removed, the advice of the Certificate holder should be sought.

8.2 Sealant joint weatherproofing may have to be renewed during the life of the cladding.

9 Durability



9.1 The product will perform effectively as a cladding panel in external conditions with an ultimate life in excess of 30 years.

9.2 After natural weathering, slight initial dulling of the surface and slight change in colour shade may occur, particularly on the dark coloured material. However, this process is not likely to be progressive.

Installation

10 General

10.1 Petrarch External Sheeting must be installed in accordance with the Certificate holder's instructions. Typical installation details are given in Figures 1 to 3.

10.2 The product is fixed to a sub-frame made of timber battens or aluminium support profiles. The spacing of the supports should be chosen in accordance with the local structural requirements, but should be no more than 600 mm.

10.3 When the sheeting is used as cladding or infill panelling, it is fixed by means of mechanical face fixings (screws for a timber batten sub-frame, or rivets for an aluminium sub-frame) or secret fixings as described in section 11. Other fixing arrangements are available but have not been assessed by the BBA and are outside the scope of this Certificate.

10.4 The product is also compatible with the SikaTack Panel Adhesive System, and should be installed in accordance with BBA Certificate 05/4218.

11 Procedure

11.1 When face-fixed, 7 mm or 10 mm thick sheets are secured to the timber or aluminium studding or sub-frame using stainless steel (grade A2) rivets or dome-headed Torx screws, of diameter 5.0 mm and 4.8 mm respectively, at maximum 600 mm centres. To allow for thermal expansion, the panel is fixed through a 5.1 mm diameter hole drilled

through the centre of the panel, all other fixing holes being drilled at 8.5 mm diameter. Installation must be carried out using a centring tool and soft set nose piece. Holes should be placed at least 25 mm from the edge of the panel.

11.2 When mechanically secret fixed, 10 mm thick panels are secured to the timber or aluminium battens or sub-frame using aluminium hanger brackets fixed to the back of the panels by means of a board anchor, fixed at maximum 600 mm centres. The panels are then secured in place by hooking on to a horizontal 'C' profile fixed continuously at maximum 600 mm centres. The top row hangers on each panel have adjustable screws to line up and level the panels in situ (see Figure 3d).

11.3 Correctly-sized expansion gaps must be left between the fitted sheets and the joints either left open or closed using a suitable solvent-free sealant or pre-formed gasket (see Figures 1 to 3).

Figure 1 Installation details — aluminium face fixing

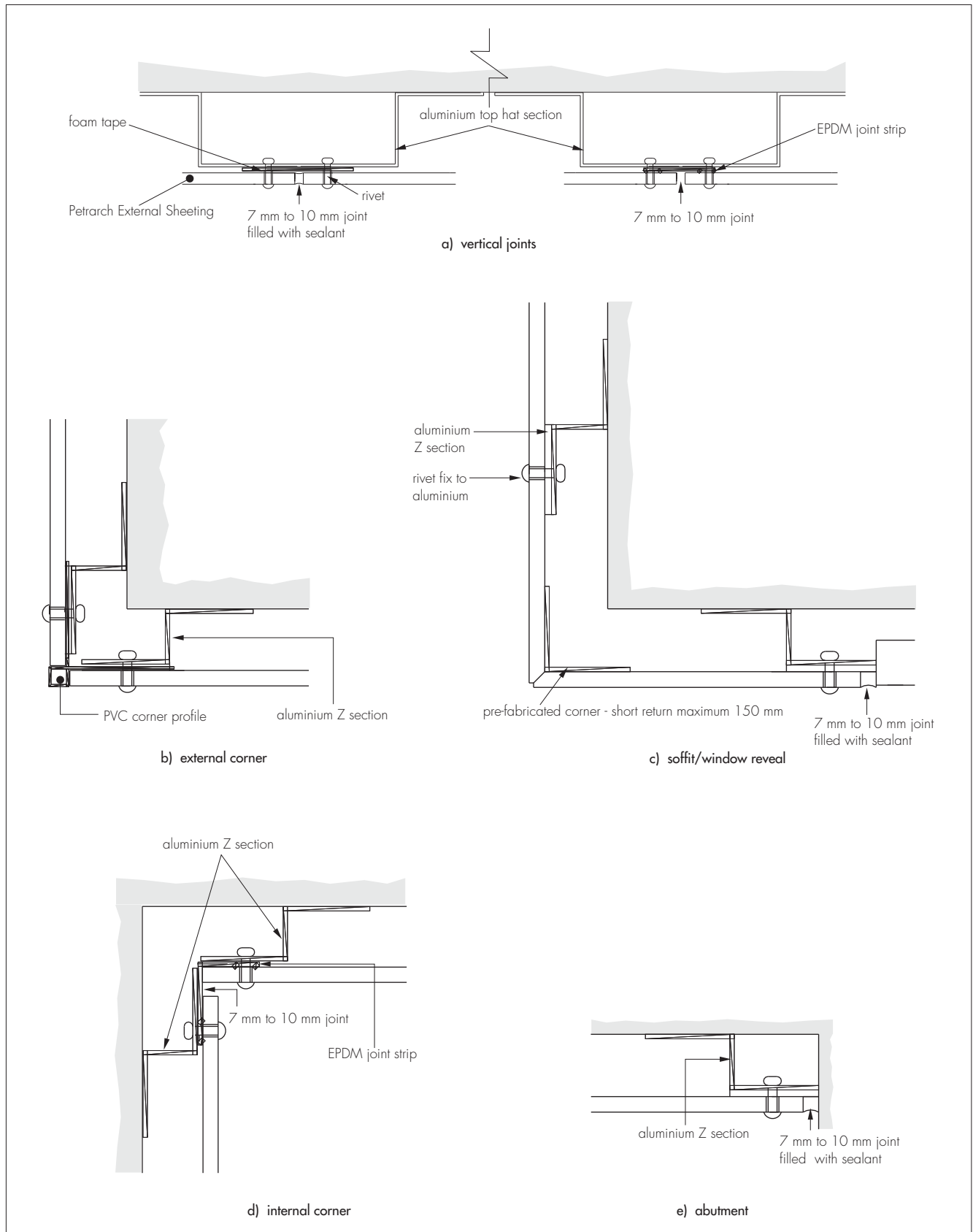

Figure 2 Installation details — timber face fixing

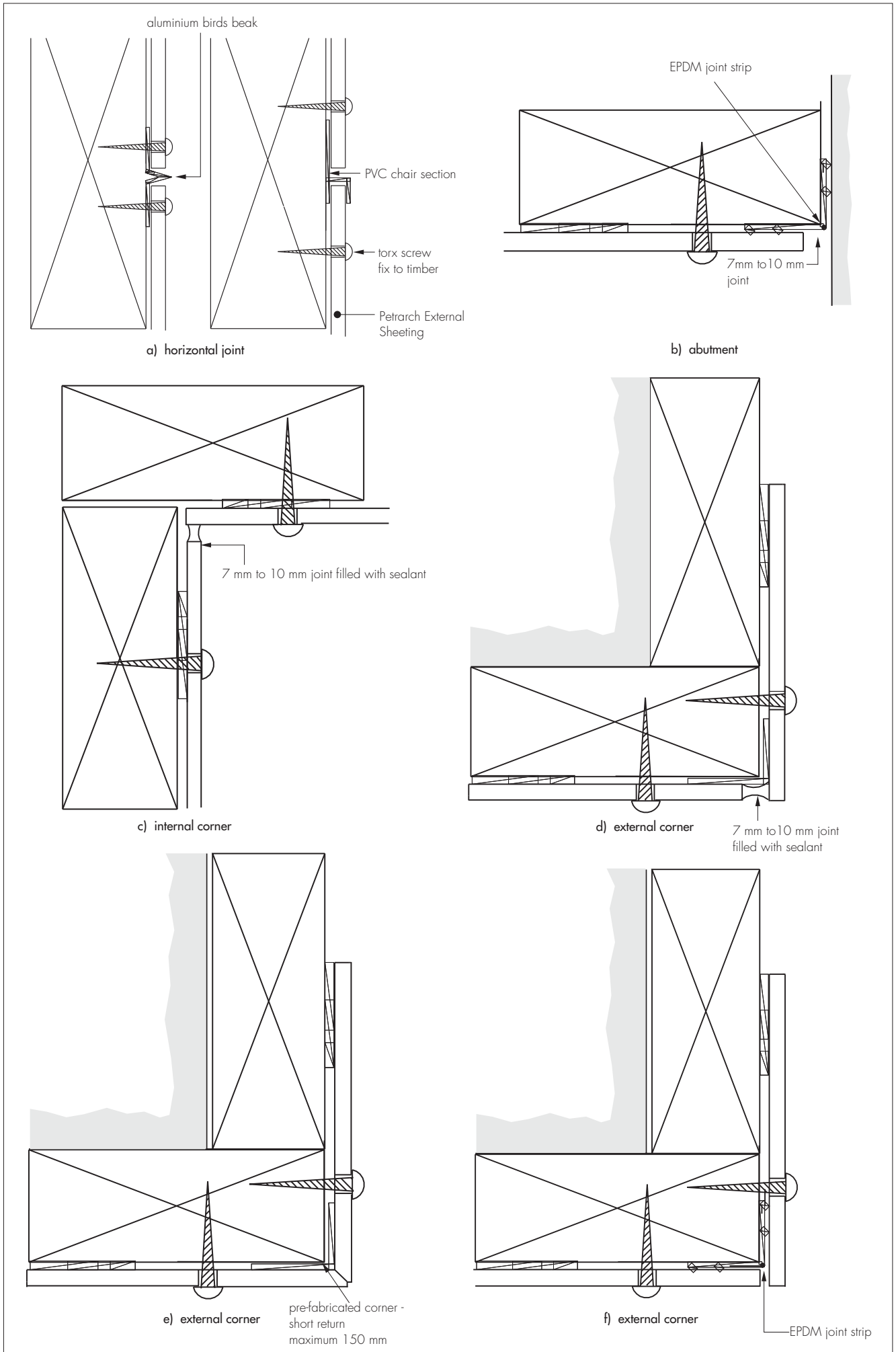
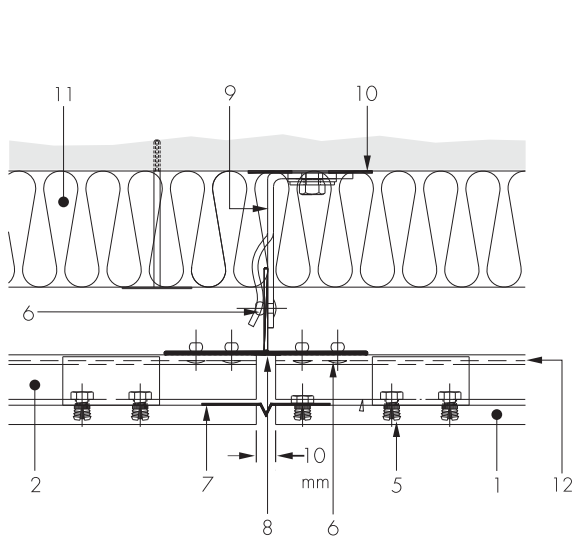
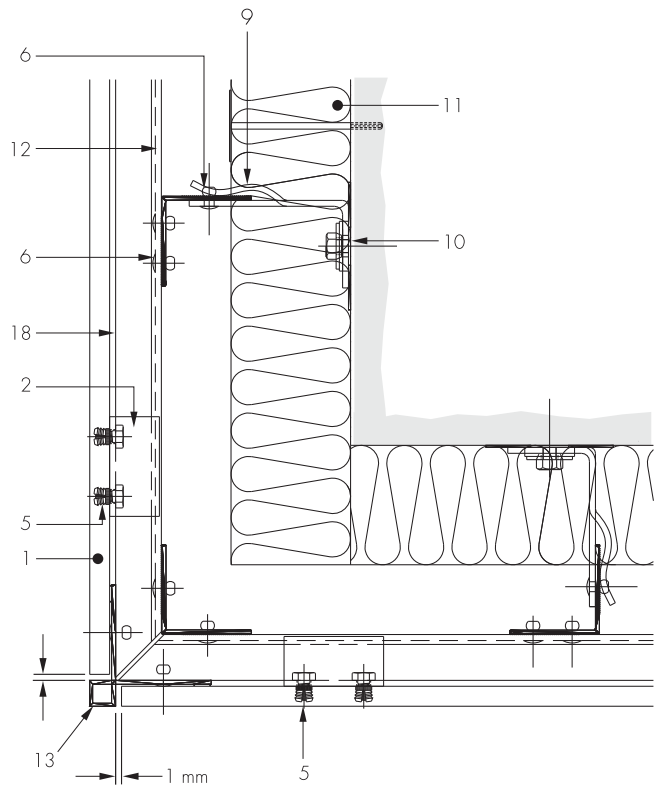

Figure 3 Installation details — aluminium secret fixing



a) vertical joint



b) external corner

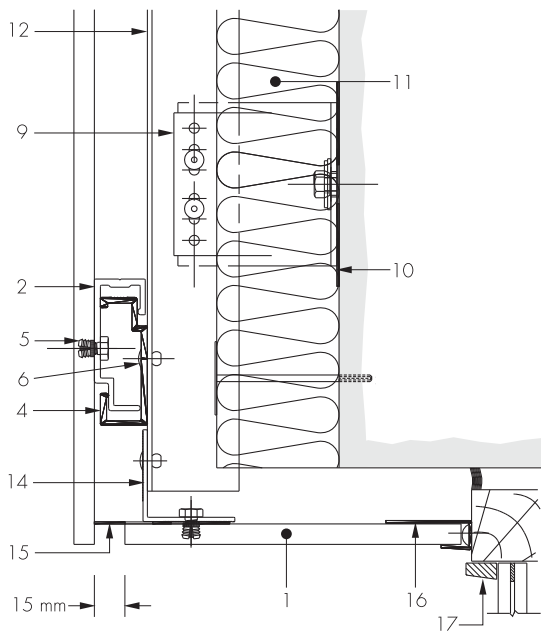

c) window head

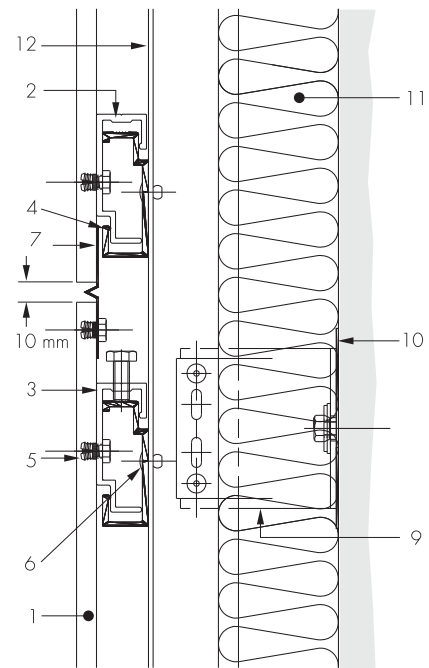

d) horizontal joint

Key

- | | |
|-----------------------------|--|
| 1 Petrach External Sheeting | 10 Isolator pad |
| 2 standard panel hanger | 11 insulation |
| 3 adjustable panel hanger | 12 vertical carrier rail |
| 4 horizontal C profile | 13 aluminium external corner profile |
| 5 PA panel insert | 14 60 mm x 40 mm angle |
| 6 framing rivet | 15 ventilation profile |
| 7 birds beaks | 16 edging profile |
| 8 vertical T profile | 17 window detail to project requirements |
| 9 F1.40 wall bracket | 18 cladding rail |

12 Tests

Tests were carried out on Petrarch External Sheeting, and the results assessed, to determine:

- simulated wind loadings
- soft body impacts of energy level up to 981 J
- hard body impacts of energy level up to 19.6 J
- ignitability
- abrasion resistance
- cross-breaking (flexural) strength
- thermal cycling and thermal shock.

13 Investigations

13.1 Independent test data were examined relating to:

- surface spread of flame
- fire propagation.

13.2 A re-examination was made of the data and investigations on which previous Certificates 75/275, 79/657 and 83/1175 were based. The conclusions drawn from the data remain valid.

13.3 A user survey was carried out to assess performance in use.

13.4 The manufacturing process for the product was examined, including the methods adopted for quality control, and details of the quality and composition of the materials used were obtained.

13.5 Test reports relating to the adhesion of SikaTack Panel Adhesive (the subject of BBA Certificate 05/4218) to Petrarch External Sheeting have been assessed by the BBA and have confirmed the compatibility of the two products.

Bibliography

- BS 476-6 : 1989 *Fire tests on building materials and structures — Method of test for fire propagation for products*
BS 476-7 : 1997 *Fire tests on building materials and structures — Method of test to determine the classification of the surface spread of flame of products*
BS 8200 : 1985 *Code of practice for design of non-loadbearing external vertical enclosures of buildings*
BS EN 1995-1-1 : 2004 *Eurocode 5 : Design of timber structures — General — Common rules and rules for buildings*
NA to BS EN 1995-1-1 : 2004 *UK National Annex to Eurocode 5 : Design of timber structures — General — Common rules and rules for buildings*
BS EN 1999-1-1 : 2007 *Eurocode 9 : Design of aluminium structures — General structural rules*
NA to BS EN 1999-1-1 : 2007 *UK National Annex to Eurocode 9 : Design of aluminium structures — General structural rules*
MOAT No 43 : 1987 *UEAtc Directives for Impact Testing Opaque Vertical Building Components*

14 Conditions

14.1 This Certificate:

- relates only to the product/system that is named and described on the front page
- is issued only to the company, firm, organisation or person named on the front page — no other company, firm, organisation or person may hold or claim that this Certificate has been issued to them
- is valid only within the UK
- has to be read, considered and used as a whole document — it may be misleading and will be incomplete to be selective
- is copyright of the BBA
- is subject to English Law.

14.2 Publications, documents, specifications, legislation, regulations, standards and the like referenced in this Certificate are those that were current and/or deemed relevant by the BBA at the date of issue or reissue of this Certificate.

14.3 This Certificate will remain valid for an unlimited period provided that the product/system and its manufacture and/or fabrication, including all related and relevant parts and processes thereof:

- are maintained at or above the levels which have been assessed and found to be satisfactory by the BBA
- continue to be checked as and when deemed appropriate by the BBA under arrangements that it will determine
- are reviewed by the BBA as and when it considers appropriate.

14.4 The BBA has used due skill, care and diligence in preparing this Certificate, but no warranty is provided.

14.5 In issuing this Certificate, the BBA is not responsible and is excluded from any liability to any company, firm, organisation or person, for any matters arising directly or indirectly from:

- the presence or absence of any patent, intellectual property or similar rights subsisting in the product/system or any other product/system
- the right of the Certificate holder to manufacture, supply, install, maintain or market the product/system
- individual installations of the product/system, including their nature, design, methods, performance, workmanship and maintenance
- any works and constructions in which the product/system is installed, including their nature, design, methods, performance, workmanship and maintenance
- any loss or damage, including personal injury, howsoever caused by the product/system, including its manufacture, supply, installation, use, maintenance and removal.

14.6 Any information relating to the manufacture, supply, installation, use, maintenance and removal of this product/system which is contained or referred to in this Certificate is the minimum required to be met when the product/system is manufactured, supplied, installed, used, maintained and removed. It does not purport in any way to restate the requirements of the Health and Safety at Work etc. Act 1974, or of any other statutory, common law or other duty which may exist at the date of issue or reissue of this Certificate; nor is conformity with such information to be taken as satisfying the requirements of the 1974 Act or of any statutory, common law or other duty of care.