

## Icopal Ltd

Barton Dock Road  
Stretford  
Manchester M32 0YL

Tel: 0161-865 4444 Fax: 0161-865 8433  
e-mail: info.uk@icopal.com  
website: www.icopal.co.uk



Agrément Certificate  
**87/1807**  
Product Sheet 2

## ICOPAL NON-BREATHABLE ROOF TILE UNDERLAYS

### MONARTILE PROTECT ROOF TILE UNDERLAY

#### PRODUCT SCOPE AND SUMMARY OF CERTIFICATE

This Certificate relates to Monartile Protect Roof Tile Underlay for use in tiled and slated ventilated pitched roofs.

#### AGRÉMENT CERTIFICATION INCLUDES:

- factors relating to compliance with Building Regulations where applicable
- factors relating to additional non-regulatory information where applicable
- independently verified technical specification
- assessment criteria and technical investigations
- design considerations
- installation guidance
- regular surveillance of production
- formal three-yearly review.

#### KEY FACTORS ASSESSED

**Weathertightness** — as part of a complete roof, the product will resist the passage of water and wind-blown snow and dust into the interior of the building (see section 5).

**Wind loading** — when installed with appropriately spaced battens the product's physical properties are deemed adequate to resist the wind loads imposed on the underlay. The product will reduce the wind uplift forces acting on the roof covering (see section 7).

**Strength** — the product has adequate strength to resist the loads associated with the installation of the roof (see section 8).

**Durability** — under the normal conditions found in a roof space the product will have a service life comparable to a traditional roof tile underlay (see section 11).

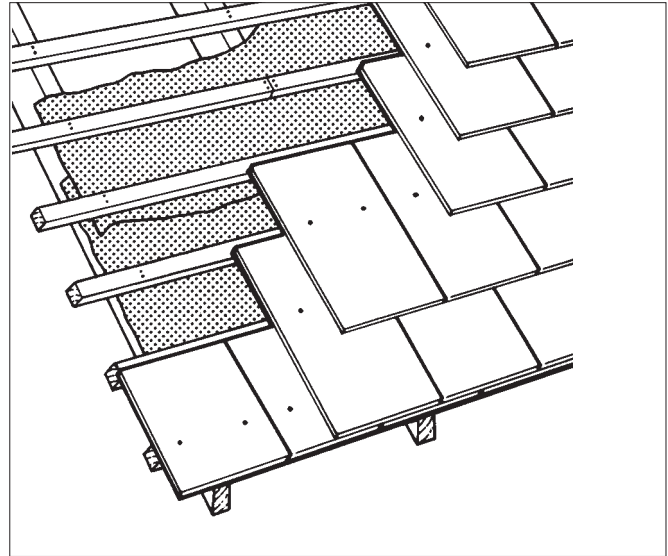

The BBA has awarded this Agrément Certificate to the company named above for the product described herein. This product has been assessed by the BBA as being fit for its intended use provided it is installed, used and maintained as set out in this Certificate.

On behalf of the British Board of Agrément

Simon Wroe  
Head of Approvals — Materials

Greg Cooper  
Chief Executive

Date of First issue: 30 January 2009

Originally certified on 31 March 2004

Certificate amended on 6 January 2011 with a change to section 12 and additional section 13.3.

The BBA is a UKAS accredited certification body — Number 113. The schedule of the current scope of accreditation for product certification is available in pdf format via the UKAS link on the BBA website at [www.bbacerts.co.uk](http://www.bbacerts.co.uk)

Readers are advised to check the validity and latest issue number of this Agrément Certificate by either referring to the BBA website or contacting the BBA direct.

British Board of Agrément  
Bucknalls Lane  
Garston, Watford  
Herts WD25 9BA

©2009

tel: 01923 665300  
fax: 01923 665301  
e-mail: [mail@bba.star.co.uk](mailto:mail@bba.star.co.uk)  
website: [www.bbacerts.co.uk](http://www.bbacerts.co.uk)

# Regulations

In the opinion of the BBA, Monartile Protect Roof Tile Underlay, if used in accordance with the provisions of this Certificate, will meet or contribute to meeting the relevant requirements of the following Building Regulations:



## The Building Regulations 2000 (as amended) (England and Wales)

Requirement:	C2(b)	Resistance to moisture
Comment:		The product will contribute to a roof meeting this Requirement. See section 5.1 of this Certificate.
Requirement:	Regulation 7	Materials and workmanship
Comment:		The product is acceptable. See section 11 and the <i>Installation</i> part of this Certificate.



## The Building (Scotland) Regulations 2004 (as amended)

Regulation:	8(1)(2)	Fitness and durability of materials and workmanship
Comment:		The product can contribute to a construction satisfying this Regulation. See sections 10 and 11, and the <i>Installation</i> part of this Certificate.
Regulation:	9	Building standards – construction
Standard:	3.10	Precipitation
Comment:		The product will contribute to a roof satisfying clauses 3.10.1 <sup>(1)(2)</sup> and 3.10.7 <sup>(1)(2)</sup> of this Standard. See section 5.1 of this Certificate.
Regulation:	12	Building standards – conversions
Comment:		All comments given for this product under Regulation 9, also apply to this Regulation, with reference to clause 0.12.1 <sup>(1)(2)</sup> and Schedule 6 <sup>(1)(2)</sup> . (1) Technical Handbook (Domestic). (2) Technical Handbook (Non-Domestic).



## The Building Regulations (Northern Ireland) 2000 (as amended)

Regulation:	B2	Fitness of materials and workmanship
Comment:		The product is acceptable. See section 11 and the <i>Installation</i> part of this Certificate.
Regulation:	B3(2)	Suitability of certain materials
Comment:		The product does not normally require maintenance. See section 10 of this Certificate.
Regulation:	C4(b)	Resistance to ground moisture and weather
Comment:		The product will contribute to a roof satisfying this Regulation. See section 5.1 of this Certificate.

## Construction (Design and Management) Regulations 2007

## Construction (Design and Management) Regulations (Northern Ireland) 2007

Information in this Certificate may assist the client, CDM co-ordinator, designer and contractors to address their obligations under these Regulations.

See section: 1 *Description* (1.2).

# Non-regulatory Information

## NHBC Standards 2008

NHBC accepts the use of Monartile Protect Roof Tile Underlay, when installed and used in accordance with this Certificate, in relation to *NHBC Standards*, Chapter 7.2 *Pitched roofs*.

## Zurich Building Guarantee Technical Manual 2007

In the opinion of the BBA, Monartile Protect Roof Tile Underlay, when installed and used in accordance with this Certificate, satisfies the requirements of the *Zurich Building Guarantee Technical Manual*, Section 4 *Superstructure*, Sub-section *Pitched roofs*.

# General

This Certificate relates to Monartile Protect Roof Tile Underlay for use in tiled or slated ventilated pitched roofs in accordance with the relevant Clauses of BS 5534 : 2003.

The product will also prevent the ingress of wind-blown rain or snow.

# Technical Specification

## 1 Description

1.1 Monartile Protect Roof Tile Underlay is a non-woven spunbonded, black polypropylene sheet laminated with a matt black, low-density polyethylene (LDPE) top layer.

1.2 The product's nominal characteristics are:

Thickness (mm)	0.45
Mass per unit area ( $\text{gm}^{-2}$ )	130
Roll length (m)	15 and 45
Roll width (m)	1
Roll weight (kg)	1.95 and 5.85
Colour	
top surface	Black (matt)
bottom surface	Black

1.3 Monarflex Eaves Guard is manufactured from UV-resistant polymer and is used to protect the underlay at eaves and allow water run-off into the gutter.

1.4 Quality control checks are carried out on the incoming materials, during production and on the finished product. Quality control checks on the finished product include:

- weight per unit area
- width
- appearance
- tear strength.

## 2 Delivery and site handling

2.1 Rolls are delivered to site in packages that carry a label bearing the marketing company's name, the product name, dimensions and the BBA identification mark including the number of this Certificate.

2.2 The rolls should be stored flat on their sides, on a smooth, clean, dry surface, under cover and protected from sunlight and heat sources. Pallets should not be stacked.

# Assessment and Technical Investigations

The following is a summary of the assessment and technical investigations carried out on Monartile Protect Roof Tile Underlay.

## Design Considerations

### 3 General

3.1 Monartile Protect Roof Tile Underlay is satisfactory for use as a roof tile underlay in tiled or slated ventilated pitched roofs constructed in accordance with the relevant Clauses of BS 5534 : 2003.

3.2 The product has a low coefficient of friction and care should be taken, especially when wet, during installation work, to avoid slipping.

### 4 Practicability of installation

Installation can be carried out readily by slaters/tilers experienced with this type of installation.

### 5 Weathertightness

 5.1 Tests indicate that the product will resist the passage of water and wind-blown snow and dust into the interior of a building, under all conditions to be found in a roof constructed in accordance with the relevant clauses of BS 5534 : 2003.

5.2 The product should not be used for prolonged periods as temporary waterproof covering prior to the installation of slates or tiles.

### 6 Risk of condensation

6.1 The product should be regarded as an impermeable underlay when considering ventilation of a roof space.

6.2 For design purposes, the product's water vapour resistance may be taken as not less than  $50 \text{ MNsg}^{-1}$ , and for roofs designed in accordance with BS 5534 : 2003 or BS 5250 : 2002, Section 8.4, they may be regarded as a Type HR membrane.

6.3 In common with all roofs, care must be taken in the overall design and installation to minimise the risk of water vapour coming into contact with cold parts of the construction. Factors to be considered and minimised include, moisture diffusion through the ceiling, infiltration through unsealed openings/penetrations in the ceilings and services evaporating or venting moisture into cold spaces.

6.4 The risk of condensation is highest in new-build construction during the first heating period, where there is high moisture loading due to wet trades, such as in-situ cast concrete slabs or plaster. The risk of condensation diminishes as the building naturally dries out. See *BBA Information Bulletin No 1 – Roof Tile Underlays in Cold Roofs during the Drying-out Period*.

#### Ceiling and insulation horizontal (cold ventilated roof)

6.5 Roofs designed and constructed in accordance with BS 5250 : 2002 will adequately limit the risk of condensation.

#### Ceiling and insulation inclined (warm roof)

6.6 For roofs with an insulated inclined ceiling, ventilation between the insulation and underlay will be required, see section 13.2.

## 7 Wind loading

7.1 Project design wind speeds should be determined and wind uplift forces calculated, in accordance with BS 6399-2 : 1997.

7.2 Wind loading on the underlay should be calculated in accordance with BS 5534 : 2003, Section 5.5.2.7. For acceptable wind loads with specific batten spacings for the draped product, using a 25 mm deep tiling batten, see section 16, Table for *Physical properties – general*.

## 8 Strength

The product will resist the normal loads associated with installation of the roof (see section 16, Table for *Physical properties – directional*).

## 9 Properties in relation to fire

9.1 The product will melt and shrink away from heat, but will burn in the presence of a naked flame.

9.2 There is a risk that fire can spread if it is accidentally ignited during maintenance works, eg by a roofer's or plumber's torch. As with all types of underlay, care should be taken during building and maintenance to avoid the material becoming ignited.

## 10 Maintenance



As the product is confined to a roof space and has suitable durability (see section 11), there are no maintenance requirements. However, it must be ensured that damage occurring before enclosure is repaired (see section 15).

## 11 Durability



The product will be virtually unaffected by the normal conditions found in a roof space and will have a life comparable with that of traditional roof tile underlay, provided it is not exposed to sunlight for long periods (see section 12.5). Advice regarding exposure can be obtained from the Certificate holder.

# Installation

## 12 General

12.1 Monartile Protect Roof Tile Underlay must be installed and fixed in accordance with the Certificate holder's instructions, provisions of this Certificate and the relevant recommendations of BS 5534 : 2003 and BS 8000-6 : 1990. Installation can be carried out under all conditions normal to roofing work.

12.2 Valleys and ridges should be covered with a 600 mm wide strip of the product.

12.3 The product is installed with the matt black side uppermost and fixed using galvanized clout nails every 150 mm and lapped to shed water out and down the slope.

12.4 Overlaps must be provided with the minimum dimensions given in Table 1.

Table 1 Minimum overlaps

Roof pitch (°)	Horizontal lap (mm)		Vertical laps (mm)
	Not fully supported	Fully supported	
12.5 to 14	225	150	100
15 to 34	150	100	100
35+	100	75	100

12.5 At the eaves, the product should be continued over the tilting fillet or fascia board to extend into the gutter.

12.6 Where possible, eaves guards must be used to protect the product from sunlight and to direct water into the gutter.

## 13 Procedure

13.1 The product is fixed in the traditional method for roof tile underlays, ie draped between the rafters to allow drainage of liquid water under the tiling battens.

13.2 When used in warm roof specifications, a ventilation gap of at least 50 mm between the insulation and the underlay should be allowed. A vapour control layer should be used on the warm side of the insulation.

13.3 The product must not be laid directly onto insulated sarking boards, but can be laid on timber sarking (ie roofing grade plywood or OSB) in conjunction with counter battens.

## 14 Finishing

14.1 Detailing of abutments and verges must be in accordance with the Certificate holder's instructions. Ingress of moisture to the roof space should be restricted by sealing around pipes and other penetrations and details.

14.2 The tiling and slating must be carried out in accordance with the relevant Clauses of BS 5534 : 2003, BS 8000-6 : 1990 and the tile/slate manufacturer's instructions, especially when using tightly-jointed slates or tiles.

## 15 Repair

Damage to the product can be repaired easily prior to the installation of slates or tiles by replacing the damaged areas, by patching and sealing correctly. Care should be taken to ensure that the watertightness of the roof is maintained.

# Technical Investigations

## 16 Tests

A sample of Monartile Protect Roof Tile Underlay was obtained from the Certificate holder for testing. The results of the tests carried out by, or on behalf of the BBA are summarised in Tables 2 and 3.

*Table 2 Physical properties — directional*

Test (units)	Mean result		Method <sup>(1)</sup>
	Long <sup>(2)</sup>	Trans <sup>(3)</sup>	
Tensile strength (N per 50 mm)			BS EN 12311-1 <sup>(4)</sup> (100 mm min <sup>-1</sup> )
unaged	149	132	
UV heat aged <sup>(5)</sup>	148	129	
Elongation at break (%)			BS EN 12311-1 <sup>(4)</sup> (100 mm min <sup>-1</sup> )
unaged	68	73	
UV aged <sup>(5)</sup>	59	68	
Tear resistance — nail (N)			BS EN 12310-1 <sup>(4)</sup>
unaged	140	150	
Dimensional stability	-0.3	-0.2	BS EN 1107-2

(1) The test documents are detailed in the *Bibliography*. Numbers in the table refer to sections/parts of the various documents.

(2) Longitudinal direction.

(3) Transverse direction.

(4) Carried out with modifications from BS EN 13859-1.

(5) 336 light hours UVA at 50°C followed by heat ageing at 70°C for 90 days.

*Table 3 Physical properties — general*

Test (units)	Mean result	Method <sup>(1)</sup>
Water vapour permeability at 25°C/75% RH (gm <sup>-2</sup> day <sup>-1</sup> )	1.08	BS 3177
Water vapour resistance (MNsg <sup>-1</sup> )	190	BS 3177
Water penetration	Class W1	BS EN 1928 <sup>(2)</sup>
Streaming water	pass	UEAtc Guide for RTU's 4.2.2
Burst strength (kNm <sup>-2</sup> )	326	BS 3137
Slip resistance (coefficient of friction)		T1/10 <sup>(3)</sup>
dry	0.49	
wet	0.39	
Resistance to wind loads (kPa) <sup>(4)</sup>		MOAT 69 (4.2.1)
batten spacing 350 mm	1.0 <sup>(5)</sup>	
batten spacing 330 mm	1.0 <sup>(5)</sup>	
batten spacing 300 mm	1.5 <sup>(5)</sup>	
batten spacing 250 mm	2.5 <sup>(5)</sup>	

(1) The test documents are detailed in the *Bibliography*. Numbers in the table refer to sections/parts of the various documents.

(2) Carried out with modifications from BS EN 13859-1.

(3) BBA Test Method.

(4) Test carried out using 25 mm thick battens and a 600 mm rafter spacing.

(5) Maximum pressure achieved.

## 17 Investigations

The manufacturing process was assessed, including the method adopted for quality control, and details were obtained of the quality and composition of the materials used.

### Bibliography

- BS 3137 : 1972 *Methods for determining the bursting strength of paper and board*
- BS 3177 : 1959 *Method for determining the permeability to water vapour of flexible sheet materials used for packaging*
- BS 5250 : 2002 *Code of practice for control of condensation in buildings*
- BS 5534 : 2003 *Code of practice for slating and tiling (including shingles)*
- BS 6399-2 : 1997 *Loading for buildings — Code of practice for wind loads*
- BS 8000-6 : 1990 *Workmanship on building sites — Code of practice for slating and tiling of roofs and claddings*
- BS EN 1928 : 2000 *Flexible sheets for waterproofing — Bitumen, plastic and rubber sheets for roof waterproofing — Determination of watertightness*
- BS EN 12310-1 : 2000 *Flexible sheets for waterproofing — Determination of resistance to tearing (nail shank) — Part 1 — Bitumen sheets for roof waterproofing*
- BS EN 12311-1 : 2000 *Flexible sheets for waterproofing — Determination of tensile properties — Part 1 — Bitumen sheets for roof waterproofing*
- BS EN 13859-1 : 2005 *Flexible sheets for waterproofing — Definitions and characteristics of underlays — Underlays for discontinuous roofing*
- BS EN ISO 527-3 : 1996 *Plastics — Determination of tensile properties — Test conditions for films and sheets*
- MOAT No 69 : 2004 *UEAtc Technical Report for the Assessment of Discontinuous Roofing Underlay Systems*

## 18 Conditions

18.1 This Certificate:

- relates only to the product/system that is named and described on the front page
- is granted only to the company, firm or person named on the front page — no other company, firm or person may hold or claim any entitlement to this Certificate
- is valid only within the UK
- has to be read, considered and used as a whole document — it may be misleading and will be incomplete to be selective
- is copyright of the BBA
- is subject to English law.

18.2 References in this Certificate to any Act of Parliament, Statutory Instrument, Directive or Regulation of the European Union, British, European or International Standard, Code of Practice, manufacturers' instructions or similar publication, are references to such publication in the form in which it was current at the date of this Certificate.

18.3 This Certificate will remain valid for an unlimited period provided that the product/system and the manufacture and/or fabrication including all related and relevant processes thereof:

- are maintained at or above the levels which have been assessed and found to be satisfactory by the BBA
- continue to be checked as and when deemed appropriate by the BBA under arrangements that it will determine
- are reviewed by the BBA as and when it considers appropriate.

18.4 In granting this Certificate, the BBA is not responsible for:

- the presence or absence of any patent, intellectual property or similar rights subsisting in the product/system or any other product/system
- the right of the Certificate holder to manufacture, supply, install, maintain or market the product/system
- individual installations of the product/system, including the nature, design, methods and workmanship of or related to the installation
- the actual works in which the product/system is installed, used and maintained, including the nature, design, methods and workmanship of such works.

18.5 Any information relating to the manufacture, supply, installation, use and maintenance of this product/system which is contained or referred to in this Certificate is the minimum required to be met when the product/system is manufactured, supplied, installed, used and maintained. It does not purport in any way to restate the requirements of the Health & Safety at Work etc Act 1974, or of any other statutory, common law or other duty which may exist at the date of this Certificate; nor is conformity with such information to be taken as satisfying the requirements of the 1974 Act or of any statutory, common law or other duty of care. In granting this Certificate, the BBA does not accept responsibility to any person or body for any loss or damage, including personal injury, arising as a direct or indirect result of the manufacture, supply, installation, use and maintenance of this product/system.

