

Vencel Resil Limited

Infinity House
Anderson Way
Belvedere
Kent DA17 6BG
Tel: 020 8320 9100 Fax: 020 8320 9110
e-mail: technical@vencel.co.uk
website: www.vencel.co.uk



Agrément Certificate
89/2179
Product Sheet 1

VR PARTIAL CAVITY WALL BOARDS

JABWALL PREMIUM

PRODUCT SCOPE AND SUMMARY OF CERTIFICATE

This Certificate relates to Jabwall Premium, an expanded polystyrene board for use as partial cavity wall insulation.

AGRÉMENT CERTIFICATION INCLUDES:

- factors relating to compliance with Building Regulations where applicable
- factors relating to additional non-regulatory information where applicable
- independently verified technical specification
- assessment criteria and technical investigations
- design considerations
- installation guidance
- regular surveillance of production
- formal three-yearly review.

KEY FACTORS ASSESSED

Thermal performance — subject to the selection of an appropriate board thickness, the construction can improve on the elemental U value. The product can maintain, or contribute to maintaining, continuity of thermal insulation at junctions between the roof and other building elements. The product has a thermal conductivity of $0.030 \text{ Wm}^{-1}\text{K}^{-1}$ ($\lambda_{90/90}$ value) (see section 5).

Liquid water penetration — the performance of the product with regard to liquid water penetration has been considered (see section 6).

Condensation — walls will limit the risk of condensation provided the conditions stated within this Certificate are met (see section 7).

Behaviour in relation to fire — the use of the product does not prejudice the fire-resistance properties of the wall. The insulation will not contribute to the development stages of a fire or present a smoke toxic hazard. The boards are classified as class E fire in accordance to BS EN 13501-1 : 2007, containing a flame-retardant additive (see section 8).

Durability — the product is rot-proof, dimensionally stable and durable and will remain effective as an insulation for the life of the building (see section 11).



The BBA has awarded this Agrément Certificate to the company named above for the product described herein. This product has been assessed by the BBA as being fit for its intended use provided it is installed, used and maintained as set out in this Certificate.

On behalf of the British Board of Agrément

Chris Hunt
Head of Approvals — Physics

Greg Cooper
Chief Executive

Date of First issue: 27 October 2008

Originally certificated on 1 March 1989

The BBA is a UKAS accredited certification body — Number 113. The schedule of the current scope of accreditation for product certification is available in pdf format via the UKAS link on the BBA website at www.bbacerts.co.uk

Readers are advised to check the validity and latest issue number of this Agrément Certificate by either referring to the BBA website or contacting the BBA direct.

British Board of Agrément
Bucknalls Lane
Garston, Watford
Herts WD25 9BA

©2008

tel: 01923 665300
fax: 01923 665301
e-mail: mail@bba.star.co.uk
website: www.bbacerts.co.uk

Regulations

In the opinion of the BBA, Jabwall Premium, if used in accordance with the provisions of this Certificate, will meet or contribute to meeting the relevant requirements of the following Building Regulations:



The Building Regulations 2000 (as amended) (England and Wales)

Requirement:	B3(4)	Internal fire spread (structure)
Comment:		Walls incorporating the product can meet this Requirement. See sections 8.2 to 8.4 of this Certificate.
Requirement:	C2(a)(b)(c)	Resistance to moisture
Comment:		Walls incorporating the product can meet this Requirement. See sections 3.2, 6.1, 6.2, 7.1 and 7.3 of this Certificate.
Requirement:	L1(a)(i)	Conservation of fuel and power
Comment:		Walls incorporating the product can contribute to a building meeting this Requirement. See sections 5.2 to 5.5 of this Certificate.
Requirement:	Regulation 7	Materials and workmanship
Comment:		The product is acceptable. See section 11 and the <i>Installation</i> part of this Certificate.



The Building (Scotland) Regulations 2004 (as amended)

Regulation:	8(1)(2)	Fitness and durability of materials and workmanship
Comment:		The product can contribute to a construction satisfying this Regulation. See sections 10 and 11 and the <i>Installation</i> part of this Certificate.
Regulation:	9	Building standards – construction
Standard:	2.4	Cavities
Comment:		A wall containing the product must comply with this Standard, with reference to clauses 2.4.1 ⁽¹⁾⁽²⁾ , 2.4.7 ⁽¹⁾ , 2.4.1 ⁽¹⁾⁽²⁾ and 2.4.9 ⁽²⁾ . See sections 8.4 and 8.5 of this Certificate.
Standard:	2.6	Spread to neighbouring buildings
Comment:		The product is combustible but may be used in walls of buildings in accordance with the exceptions permitted in this Standard, with reference to clause 2.6.5 ⁽¹⁾⁽²⁾ . See section 8.4 of this Certificate.
Standard:	3.4	Moisture from the ground
Comment:		The product does not absorb water by capillary action and, therefore, may be used where it bridges the dpc of either leaf, with reference to clause 3.4.5 ⁽¹⁾⁽²⁾ to this Standard. See section 6.1 of this Certificate.
Standard:	3.10	Precipitation
Comment:		Walls incorporating the product can satisfy this Standard, with reference to clauses 3.10.1 ⁽¹⁾ , 3.10.4 ⁽¹⁾ and 3.10.5 ⁽¹⁾ . See section 6.2 of this Certificate.
Standard:	3.15	Condensation
Comment:		Walls incorporating the product can satisfy this Standard, with reference to clauses 3.15.1 ⁽¹⁾ , 3.15.4 ⁽¹⁾ and 3.15.5 ⁽¹⁾ . See sections 3.2, 7.2 and 7.3 of this Certificate.
Standard:	6.1(a)(b)	Carbon dioxide emissions
Standard:	6.2	Building insulation envelope
Comment:		Walls incorporating the product can satisfy, or contribute to satisfy this Standard, with reference to clauses 6.1.2 ⁽¹⁾⁽²⁾ , 6.1.3 ⁽²⁾ , 6.1.6 ⁽¹⁾ , 6.2.1 ⁽¹⁾⁽²⁾ , 6.2.3 ⁽¹⁾ , 6.2.4 ⁽¹⁾⁽²⁾ , 6.2.9 ⁽¹⁾ , 6.2.10 ⁽²⁾ , 6.2.11 ⁽¹⁾ and 6.2.12 ⁽²⁾ . See sections 5.2 to 5.5 of this Certificate.
Regulation:	12	Building standards – conversions
Comment:		All comments given for this product under Regulation 9, also apply to this Regulation, with reference to clause 0.12.1 ⁽¹⁾ and Schedule 6 ⁽¹⁾ . (1) Technical Handbook (Domestic). (2) Technical Handbook (Non-Domestic).



The Building Regulations (Northern Ireland) 2000 (as amended)

Regulation:	B2	Fitness of materials and workmanship
Comment:		The product is acceptable. See section 11 and the <i>Installation</i> part of this Certificate of this Certificate.
Regulation:	B3(2)	Suitability of certain materials
Comment:		The product does not normally require maintenance. See section 10 of this Certificate.
Regulation:	C4(a)(b)	Resistance to ground moisture and weather
Comment:		Walls incorporating the product can satisfy this Regulation. See sections 3.2 and 6.2 of this Certificate. In addition, the product may be used where it bridges the dpc in either leaf. See section 6.1 of this Certificate.
Regulation:	C5	Condensation
Comment:		Walls incorporating the product can satisfy this Regulation. See section 7.3 of this Certificate.
Regulation:	E4(4)	Internal fire spread – Structure
Comment:		Walls incorporating the product can satisfy this Regulation. See sections 8.2 to 8.4 of this Certificate.
Regulation:	F2(a)(i)	Conservation measures
Comment:		Walls incorporating the product can satisfy this Regulation. See sections 5.2 to 5.5 of this Certificate.
Regulation:	F3	Target carbon dioxide Emissions Rate
Comment:		The product can contribute to a building satisfying its target emission rate. See section 5.2 of this Certificate.

Construction (Design and Management) Regulations 2007
Construction (Design and Management) Regulations (Northern Ireland) 2007

Information in this Certificate may assist the client, CDM co-ordinator, designer and contractors to address their obligations under these Regulations.

See section: 2 *Delivery and site handling* (2.2 to 2.4).

Non-regulatory Information

NHBC Standards 2008

NHBC accepts the use of Jabwall Premium, when installed and used in accordance with this Certificate, in relation to *NHBC Standards*, Chapter 6.1 *External masonry walls*.

Zurich Building Guarantee Technical Manual 2007

In the opinion of the BBA, Jabwall Premium, when installed and used in accordance with this Certificate, satisfies the requirements of the *Zurich Building Guarantee Technical Manual*, Section 4 *Superstructure*, Sub-sections *External walls – Masonry*, *External walls – Thermal insulation*.

General

This Certificate relates to Jabwall Premium, for use in buildings over 12 metres and up to 25 metres in height, subject to the conditions contained in the *Design Considerations* part of this Certificate.

The product is installed during construction and is for use as a partial fill board to reduce the thermal transmittance of new cavity walls with masonry inner and outer leaves.

Technical Specification

1 Description

1.1 Jabwall Premium comprises EPS 70 expanded polystyrene board manufactured to BS EN 13163 : 2001.

1.2 In relation to reaction-to-fire tests, the boards are classified as class E in accordance with BS EN 13501-1 : 2007.

1.3 The board has the nominal characteristics of:

Size (mm) 1200 x 450

Thickness (mm) 40, 50, 60, 75 and 100⁽¹⁾

(1) Other thicknesses available to order.

1.4 Only BBA-approved insulation retaining fixings and compatible wall ties should be used with the boards.

1.5 Cavity wall ties in accordance with BS DD 140-2 : 1987 or BS EN 845-1 : 2003 and BS 5628-3 : 2005, approved by the BBA, are suitable.

1.6 Where the overall cavity width exceeds 75 mm, additional vertical twist ties may be required for structural stability in accordance with BS 5628-3 : 2005 (see section 1.3 of this Certificate).

2 Delivery and site handling

2.1 The boards are delivered to site in packs wrapped in polythene. Each pack contains a label with the manufacturer's trade name and the BBA identification mark incorporating the number of this Certificate.

2.2 The product must be protected from prolonged exposure to sunlight and should be stored either under cover or protected with opaque polythene sheeting.

2.3 The board must be stored fully supported and flat on a firm, level and dry base, protected from the weather and raised above damp surfaces.

2.4 Care must be taken to avoid contact with solvents and bitumen products. The board must not be exposed to open flame or other ignition sources.

Assessment and Technical Investigations

The following is a summary of the assessment and technical investigations carried out on Jabwall Premium.

3 General

3.1 Jobwall Premium, when installed in accordance with this Certificate, is effective in reducing the U value (thermal transmittance) of new external cavity walls with masonry inner and outer leaves (where masonry includes clay and calcium silicate bricks, concrete blocks, natural and reconstituted stone blocks). It is essential that such walls are designed and constructed so as to incorporate the precautions given in this Certificate to prevent moisture penetration.



3.2 Buildings subject to national Building regulations should be constructed in accordance with the relevant recommendations of:

- BS 5628-3 : 2005. In particular, Clause 5.5 of the Code of Practice *Exclusion of water* should be followed in that the designer should select a construction appropriate to the local wind-driven rain index, paying due regard to the design detailing, workmanship and materials to be used⁽¹⁾.
- BS 8000-3 : 2001.

3.3 Other buildings not subject to these Regulations should also be built in accordance with the Standards given in 3.2 of this Certificate.

3.4 As with all cavity wall insulation, the construction and detailing should comply with good practice as described in the BBA joint publication *Cavity Insulation of Masonry Walls – Dampness Risks and How to Minimise Them*. They are particularly important in areas subject to severe or very severe driving rain.

3.5 The use of cavity battens and/or boards during construction is strongly recommended to prevent bridging by mortar droppings.

3.6 As with any other form of cavity wall insulation, where buildings need to comply with *NHBC Standards 2008* or *Zurich Building Guarantee Technical Manual 2007*, specifiers should observe the requirements of these documents.

Buildings up to and including 12 metres high

3.7 Where a residual cavity width of 50 mm or greater is specified the product can be used in any exposure zone. However, the use of the board does not preclude the need to apply any external render coat or other suitable finish in severe exposure zones where such application would be normal practice.

3.8 The minimum residual cavity width to be maintained during construction must be 25 mm. To achieve this requirement a greater nominal residual cavity width may need to be specified at the design stage to allow for inaccuracies inherent in the building process. The specifier may either:

- design a cavity width by consideration of the dimensional tolerances of the components which make up the wall by reference to the British Standards relating to the bricks, blocks and boards, or use the data from their respective manufacturers. In addition, allowance may need to be made for the quality of available building operatives and the degree of site supervision or control available, or
- design a nominal residual cavity width of 50 mm (a residual cavity nominally 50 mm wide will be required by the NHBC, where normal standards of tolerance and workmanship are adopted).

3.9 The size of residual cavity obtained in the processes described in section 3.8 is also subject to the following limitations in respect of exposure of the proposed building as set out in Table 1.

Table 1 Maximum allowable total exposure factors of different constructions

Construction	Maximum allowable exposure factor E
All external masonry walls protected by: rendering (to BS 5262) tile hanging slate hanging timber, plastic or metal weatherboarding or cladding	No restriction
One or more external masonry walls constructed from facing clay brickwork or natural stone, the porosity of which exceeds 20% by volume. Mortar joints must be flush pointed or weatherstruck.	100
One or more external masonry walls constructed from calcium silicate bricks, concrete blocks, reconstituted stone, or natural stone, the porosity of which is less than 20% by volume, or any material with raked mortar joints.	88

Buildings over 12 metres high and up to and including 25 metres high

3.10 The width of residual clear cavity to be achieved is to be a minimum of 50 mm, and the following requirements apply:

- from ground level the maximum height of continuous cavity walls must not exceed 12 metres; above 12 metres the maximum height of continuous cavity walls must not exceed 7 metres
- the specifier must take care when detailing to ensure that the introduction of the insulation does not affect the weather resistance of the wall. More than average site supervision is recommended during the installation of the product

- the exposure factor does not exceed 120
- where, for structural reasons, the cavity width is reduced, eg by the intrusion of ring beams, a minimum residual cavity width of 25 mm must be maintained and extra care must be taken with fixings and weatherproofing, eg inclusion of a cavity tray.

4 Practicability of installation

The product can be installed easily by operatives experienced with this type of product.

5 Thermal performance

5.1 Calculations of the thermal transmittance (U value) of specific external wall constructions should be carried out in accordance with BS EN ISO 6946 : 1997 and BRE report (BR 443 : 2006) *Conventions for U-value calculations*, using a declared thermal conductivity ($\lambda_{90/90}$ value) of $0.030 \text{ Wm}^{-1}\text{K}^{-1}$. The U value of a typical brick and block cavity wall construction will depend on the thickness of the board, the cavity width and the insulating value of the internal block leaf and finish. Example U values are given in Table 2.

Table 2 Typical cavity wall U values ($\text{Wm}^{-2}\text{K}^{-1}$)⁽¹⁾

Jabwall Premium width (mm)	Dense concrete block ($\lambda=1.13 \text{ Wm}^{-1}\text{K}^{-1}$) $d=1800 \text{ kgm}^{-3}$	Aerated concrete block ($\lambda=0.12 \text{ Wm}^{-1}\text{K}^{-1}$) $d=400 \text{ kgm}^{-3}$
40	0.52	0.40
50	0.44	0.35
65	0.36	0.31
75	0.32	0.28
100	0.26	0.23

(1) Assuming dense plaster thickness 13 mm ($\lambda=0.57 \text{ Wm}^{-1}\text{K}^{-1}$).



5.2 Subject to the selection of an appropriate insulation thickness and construction, walls can contribute to achieving the following design U values:

England and Wales and Northern Ireland

- $0.30 \text{ Wm}^{-2}\text{K}^{-1}$ standard for new thermal elements such as those constructed as part of an extension specified in Approved Documents L1B, Table 4, and L2B, Table 6
- $0.35 \text{ Wm}^{-2}\text{K}^{-1}$ thermal elements constructed as replacements for existing elements as specified in Approved Documents L1B, Table 4, and L2B, Table 6
- $0.35 \text{ Wm}^{-2}\text{K}^{-1}$ required for 'notional' buildings in SAP 2005 and buildings other than dwellings in SBEM
- $0.35 \text{ Wm}^{-2}\text{K}^{-1}$ limit average value specified in Approved Documents L1A, Table 2, and L2A, Table 4, and Technical Booklets F1, Table 2.2, and F2, Table 2.4 (see also section 5.1)
- $0.70 \text{ Wm}^{-2}\text{K}^{-1}$ limit for an individual element specified in Approved Documents L1A, Table 2, and L2A, Table 4, and Technical Booklets F1, Table 2.2, and F2, Table 2.4.

Scotland

- $0.20 \text{ Wm}^{-2}\text{K}^{-1}$ required for the 'simplified approach — solid fuel package 6' 'notional' dwelling in Mandatory Standard 6.1, clause 6.1.6⁽¹⁾ (see also section 5.3)
- $0.25 \text{ Wm}^{-2}\text{K}^{-1}$ required for 'notional' buildings in SAP 2005 (Scotland) and the 'simplified approach — packages 1 to 5' in Mandatory Standard 6.1, clause 6.1.6⁽¹⁾
- $0.27 \text{ Wm}^{-2}\text{K}^{-1}$ maximum U value for building elements of the insulation envelope for extensions or reconstruction of elements in Mandatory Standard 6.2, clauses 6.2.9⁽¹⁾ and 6.2.11⁽¹⁾
- $0.30 \text{ Wm}^{-2}\text{K}^{-1}$ limit average specified in Mandatory Standard 6.2, clause 6.2.1⁽¹⁾
- $0.70 \text{ Wm}^{-2}\text{K}^{-1}$ limit for an individual element specified in Mandatory Standard 6.2, clauses 6.2.1⁽¹⁾ and 6.2.9⁽¹⁾.

(1) Technical Handbook (Domestic).

5.3 Where a proposed wall U value is not better than (or is greater than in Scotland) the relevant 'notional' value specified in section 5.2, additional energy measures will be required in the building envelope and/or services to achieve the required overall carbon dioxide emission rate reduction of about 20% in dwellings (18% to 25% in Scotland) and 23% to 28% in buildings other than dwellings.

5.4 Compliance with the guidance referred to in section 5.2 will allow the use of the default psi values from Table 3 of BRE Information Paper IP/O6 *Assessing the effects of thermal bridging at junctions and around openings* and Table K1 of *The Government's Standard Assessment Procedure for Energy Rating of Dwellings* (SAP 2005), in Target Emission Rate calculations to SAP 2005 or the Simplified Building Energy Model (SBEM) ('simplified approach' in Scotland).

5.5 The product can maintain or contribute to maintaining continuity of thermal insulation at junctions between the external wall and the other building elements. Guidance in this respect, and on limiting heat loss by air infiltration, can be found in:

England and Wales — *Limiting thermal bridging and air leakage: Robust construction details for dwellings and similar buildings* TSO 2002

Scotland — Accredited Construction Details (Scotland)

Northern Ireland — Accredited Construction Details (version 1.0).

6 Liquid water penetration



6.1 When the product is used in situations where it bridges the dpc in walls, dampness from the ground will not pass through to the inner leaf provided the cavity wall is detailed in accordance with the requirements and provisions of the national Building Regulations:

England and Wales — Approved Document C2(a)

Scotland — Mandatory Standard 3.4, clause 3.4.1⁽¹⁾⁽²⁾

(1) Technical Handbook (Domestic).

(2) Technical Handbook (Non-Domestic).

Northern Ireland — Technical Booklet C, Section 1.6.

6.2 Constructions built in accordance with BS 5628-3 : 2005, will resist the transfer of precipitation to the inner leaf and satisfy the national Building Regulations:

England and Wales — Requirement C2(b)

Scotland — Mandatory Standard 3.10, clause 3.10.1⁽¹⁾⁽²⁾

(1) Technical Handbook (Domestic).

(2) Technical Handbook (Non-Domestic).

Northern Ireland — Regulation C4.

6.3 In all situations it is particularly important to ensure during installation that:

- the dpc should not project into cavity at ground-floor level as it can lead to catching mortar droppings
- installation is to be carried out to the highest level on each wall or the top edge of the insulation is protected by a cavity tray
- wall ties are installed correctly and are thoroughly clean
- boards are properly installed with weathered lap
- at lintel level, a cavity tray, stop ends and weepholes, must be provided
- excess mortar is cleaned from the cavity face of the leading leaf and any debris removed from the cavity
- mortar droppings are cleaned from the exposed edges of installed boards.

7 Condensation

Surface condensation



7.1 Walls will limit the risk of surface condensation adequately when the thermal transmittance (U value) does not exceed $0.7 \text{ Wm}^{-2}\text{K}^{-1}$ at any point, and the junctions with floors, roofs and openings are designed in accordance with *Limiting thermal bridging and air leakage: Robust construction details for dwellings and similar buildings* TSO 2002 or BRE Information Paper IP 1/06.



7.2 For buildings in Scotland, other constructions will also be acceptable where the thermal transmittance (U value) of the wall does not exceed $1.2 \text{ Wm}^{-2}\text{K}^{-1}$ at any point and openings and junctions with other elements comply with the guidance given in Section 8 of BS 5250 : 2002, BRE report (BR 262 : 2002) *Thermal insulation: avoiding risks* or Technical Booklet, Annex 6D, of the Scottish Building Regulations.

Interstitial condensation



7.3 Walls will limit the risk of interstitial condensation adequately when they are designed and constructed in accordance with BS 5250 : 2002 (Section 8 and Annex D).

7.4 The product has a nominal vapour resistivity exceeding $100 \text{ MNsg}^{-1}\text{m}^{-1}$ and, therefore, will provide a significant resistance to water vapour transmission. Joints between boards will facilitate the passage of water vapour under normal conditions of temperature and humidity.

7.5 If the product is to be used in the external walls of rooms expected to have high humidity, care must be taken to provide adequate permanent ventilation to avoid possible problems from the formation of interstitial condensation in the internal wall leaf.

8 Behaviour in relation to fire

8.1 The board may be classified according to BS EN 13501-1 : 2007 as a Class E material. The use of the board does not prejudice the fire-resistance properties of the wall. It is unlikely to become ignited within the cavity when used in the context of this Certificate. If fire does penetrate into an unventilated cavity, the amount of air present will be insufficient to support combustions, and flame spread will be minimal.



8.2 The requirements of the Building Regulations relating to fire spread in cavity walls can be met in buildings of all purpose groups without the need for cavity barriers, provided the construction complies with the provisions detailed in:

England and Wales — Approved Document B, Volume 1, Diagram 13 and Volume 2, Diagram 34

Northern Ireland — Technical Booklet E, Diagram 3.5.

8.3 A summary of these provisions is given here:

- the wall must consist of masonry inner and outer leaves, each at least 75 mm thick
- the cavity must not be more than 300 mm wide (Northern Ireland only)
- the cavity must be closed at the top of the wall and at the top of any opening
- in addition to the insulation only the following combustible materials shall be placed in, or exposed to, the cavity:
 - timber lintels, window or door frames, or end of timber joists
 - pipe, conduit or cable
 - dpc, flashing, cavity closer or wall tie
 - domestic meter cupboard, provided that there are not more than two cupboards to a dwelling, the opening in the outer leaf is not more than 800 mm by 500 mm for each cupboard, and the inner leaf is not penetrated except by a sleeve not more than 80 mm by 80 mm, which is fire-stopped.



8.4 For constructions not covered by sections 8.2 and 8.3 cavity barriers must be provided to comply with:

England and Wales — Approved Document B, Volume 1, Section 6 and Volume 2, Section 9

Scotland — Mandatory Standard 2.4, clauses 2.4.1⁽¹⁾ and 2.4.2⁽¹⁾, 2.4.7⁽¹⁾ and 2.4.9⁽²⁾

(1) Technical Handbook (Domestic).

(2) Technical Handbook (Non-Domestic).

Northern Ireland — Technical Booklet E, Paragraphs 3.27 to 3.30.



8.5 The product is combustible but may be used in a wall not more than one metre from a boundary, where no storey is at a height of more than 18 m above ground, unless the insulation is within a cavity of two leaves of masonry/concrete at least 75 mm thick with cavity barriers around all openings and at the top of the wall in accordance with Mandatory Standard 2.6, clauses 2.6.5⁽¹⁾, 2.6.6⁽²⁾ and Annex 2A.

(1) Technical Handbook (Domestic).

(2) Technical Handbook (Non-Domestic).

9 Proximity of flues and appliances

When installing the product in close proximity to certain flue pipes and/or heat-producing appliances, the following provisions to the national Building Regulations are acceptable:

England and Wales — Approved Document J

Scotland — Mandatory Standard 3.19

Northern Ireland — Technical Booklet L.

10 Maintenance



As the product is confined within the wall cavity and it has suitable durability (see section 11), maintenance is not required.

11 Durability



The product is durable, rot-proof, water resistant and sufficiently stable to remain effective as an insulation for the life of the building.

12 General

12.1 The walls are constructed leading with either the inner or outer leaf with the boards fixed to the cavity face of the leading leaf. It is recommended that the inner leaf be constructed ahead of the outer leaf, as the boards are fastened to the cavity face of the inner leaf. This gives a slightly enhanced thermal performance to the wall.

Supervision requirements (buildings over 12 metres and up to 25 metres in height)

12.2 To comply with this Certificate, the Certificate holder's specialists experienced in site practice and installation will attend the site to provide demonstrations to ensure correct installation from the outset.

12.3 Adequate supervision of the installation must be maintained and the Certificate holder's specialists must have right of access to site to ensure correct installation.

13 Procedure

13.1 A section of the leading leaf is built with the first row of wall ties, at approximately 600 mm horizontal spacing, where the insulation is to begin. The first run of boards may commence below damp-proof course level to provide some edge insulation for the floor (see Figure 1).

Figure 1 First run of boards

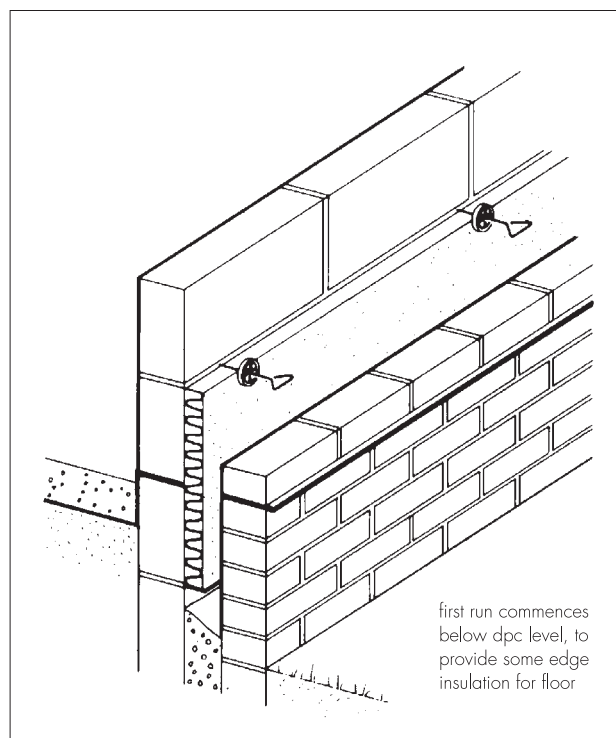

13.2 The leading leaf is then built up to the required height with wall ties placed at a vertical spacing of 450 mm. Excess mortar is cleaned from the cavity face of the leading leaf, and the boards are placed on the wall ties behind the retaining clips, to form closely butt-jointed runs. It is essential that all wall ties slope downwards towards the outer leaf (see Figure 2).

Figure 2 Wall tie detail

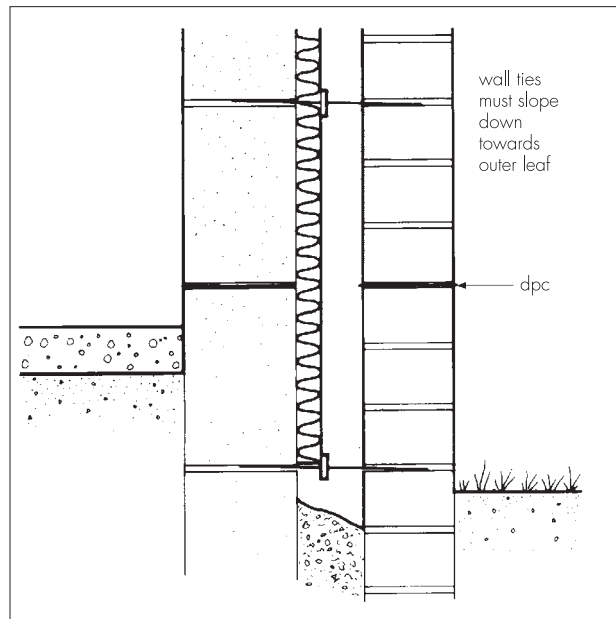

13.3 Horizontal spacing should be determined thus:

- where insulation retaining ties/clips are sufficient for structural purposes, horizontal spacing⁽¹⁾ should be 450 mm or 600 mm depending on the thickness of the thinner leaf
- where the thickness of the board is greater than 50 mm and therefore the overall cavity width exceeds 75 mm, vertical twist ties are required, in accordance with BS 5628 : 2005, and if they do not have insulation retaining clips additional insulation retaining ties and clips should be installed, spaced at 600 mm centres to give adequate retention of the board.

(1) Although a maximum horizontal spacing of 900 mm is permitted for structural purposes by BS 5628-3 : 2005, the spacing should be no more than 600 mm to ensure adequate retention of the boards.

13.4 The other leaf is then built up to the level of the top of the board.

Mortar droppings

13.5 After each section of the leading leaf is built, excess mortar should be removed from the cavity face and mortar droppings cleaned from exposed edges of the installed board, before installation of the next run of boards. Use of a cavity board is recommended to protect board edges and make cleaning easier. Also, a cavity batten will protect the installed boards and help to keep the cavity clean as the following leaf is built (see Figures 3 and 4).

Figure 3 Use of cavity board

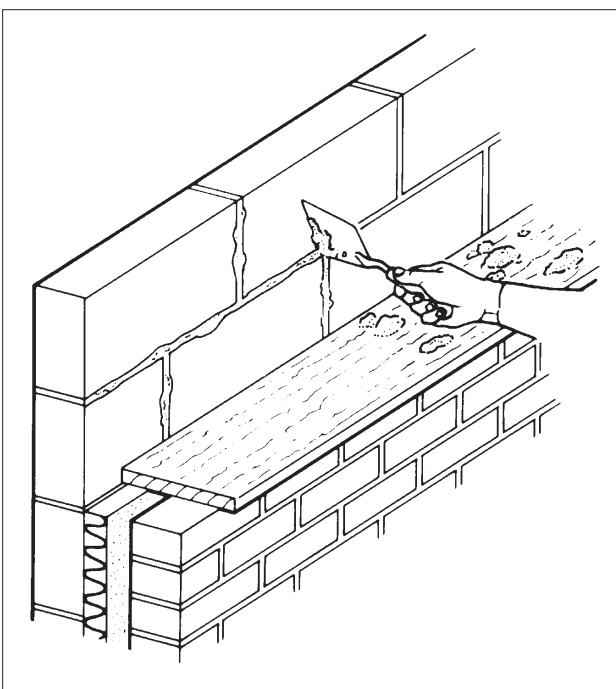
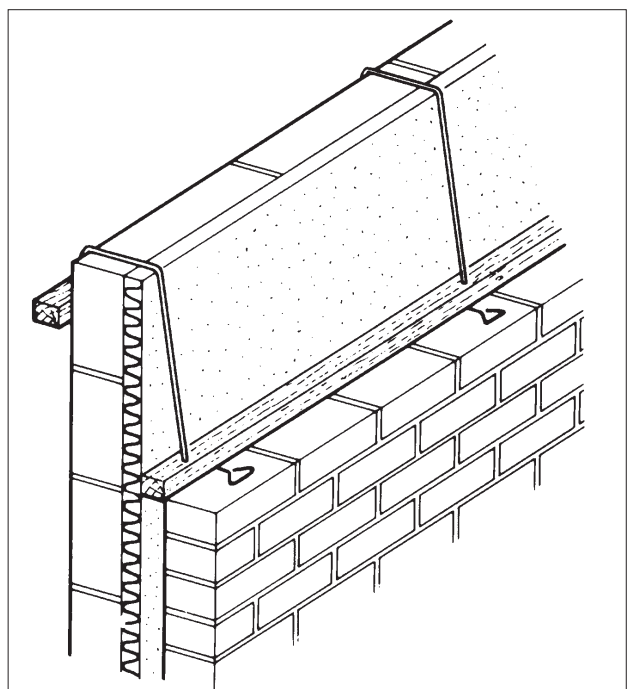

Figure 4 Use of cavity batten



Cut pieces

13.6 Boards can be cut, using a sharp knife or fine-toothed saw, to fit around areas like windows, doors and air bricks. It is essential that cut pieces completely fill the spaces for which they are intended and that no gaps are left in the insulation.

Protection

13.7 All building involving the boards, particularly work which is interrupted, must conform to BS 5628-3 : 2005, Sections 4, clauses 30 *Storage on site*, 35 *Protection against damage during construction*, and 36 *Supervision*.

Technical Investigations

14 Tests

As part of the assessment tests were carried out to determine:

- density of the boards
- dimensional accuracy
- suitability of fixing methods.

15 Investigations

15.1 A re-examination was made of the data on which Certificate 82/1042 was based.

15.2 Regular factory inspections have been carried out to ensure that quality is being maintained.

15.3 A user survey was carried out to assess the practicability of installation and to evaluate performance in use.

15.4 No failure of the system in use has been reported to the BBA.

Bibliography

- BS 5250 : 2002 *Code of practice for control of condensation in buildings*
- BS 5262 : 1991 *Code of practice for external renderings*
- BS 5628-3 : 2005 *Code of practice for the use of masonry — Materials and components, design and workmanship*
- BS 8000-3 : 2001 *Workmanship on building sites — Code of practice for masonry*
- BS DD 140-2 : 1987 *Wall ties — Recommendations for design of wall ties*
- BS EN 845-1 : 2003 *Specification for ancillary components for masonry — Ties, tension straps, hangers and brackets*
- BS EN 13163 : 2001 *Thermal insulation products for buildings — Factory made products of expanded polystyrene (EPS) — Specification*
- BS EN 13501-1 : 2007 *Fire classification of construction products and building elements. Classification using test data from reaction to fire tests*
- BS EN ISO 6946 : 1997 *Building components and building elements — Thermal resistance and thermal transmittance — Calculation method*

16 Conditions

16.1 This Certificate:

- relates only to the product/system that is named and described on the front page
- is granted only to the company, firm or person named on the front page — no other company, firm or person may hold or claim any entitlement to this Certificate
- is valid only within the UK
- has to be read, considered and used as a whole document — it may be misleading and will be incomplete to be selective
- is copyright of the BBA
- is subject to English law.

16.2 References in this Certificate to any Act of Parliament, Statutory Instrument, Directive or Regulation of the European Union, British, European or International Standard, Code of Practice, manufacturers' instructions or similar publication, are references to such publication in the form in which it was current at the date of this Certificate.

16.3 This Certificate will remain valid for an unlimited period provided that the product/system and the manufacture and/or fabrication including all related and relevant processes thereof:

- are maintained at or above the levels which have been assessed and found to be satisfactory by the BBA
- continue to be checked as and when deemed appropriate by the BBA under arrangements that it will determine
- are reviewed by the BBA as and when it considers appropriate.

16.4 In granting this Certificate, the BBA is not responsible for:

- the presence or absence of any patent, intellectual property or similar rights subsisting in the product/system or any other product/system
- the right of the Certificate holder to manufacture, supply, install, maintain or market the product/system
- individual installations of the product/system, including the nature, design, methods and workmanship of or related to the installation
- the actual works in which the product/system is installed, used and maintained, including the nature, design, methods and workmanship of such works.

16.5 Any information relating to the manufacture, supply, installation, use and maintenance of this product/system which is contained or referred to in this Certificate is the minimum required to be met when the product/system is manufactured, supplied, installed, used and maintained. It does not purport in any way to restate the requirements of the Health & Safety at Work etc Act 1974, or of any other statutory, common law or other duty which may exist at the date of this Certificate; nor is conformity with such information to be taken as satisfying the requirements of the 1974 Act or of any statutory, common law or other duty of care. In granting this Certificate, the BBA does not accept responsibility to any person or body for any loss or damage, including personal injury, arising as a direct or indirect result of the manufacture, supply, installation, use and maintenance of this product/system.