

Rockwool Ltd

26/28 Hammersmith Grove
Hammersmith
London W6 7HA

Tel: 01656 862621 Fax: 01656 862302
e-mail: customer.support@rockwool.co.uk
website: www.rockwool.co.uk



Agrément Certificate
90/2437
Product Sheet 1

ROCKSHIELD EXTERNAL WALL INSULATION SYSTEMS

THE ROCKSHIELD LW EXTERNAL WALL INSULATION SYSTEM

PRODUCT SCOPE AND SUMMARY OF CERTIFICATE

This Certificate relates to the Rockshield LW External Wall Insulation System, an external wall insulation system employing mineral wool insulation, with a glass-fibre reinforcing mesh and render finishes. It is for use on new and existing, domestic and non-domestic buildings.

AGRÉMENT CERTIFICATION INCLUDES:

- factors relating to compliance with Building Regulations where applicable
- factors relating to additional non-regulatory information where applicable
- independently verified technical specification
- assessment criteria and technical investigations
- design considerations
- installation guidance
- regular surveillance of production
- formal three-yearly review.



KEY FACTORS ASSESSED

Thermal performance — the system can be used to improve thermal performance of an external wall (see section 5).

Strength and stability — the system can adequately resist wind loads and in certain applications impact damage (see section 6).

Behaviour in relation to fire — the system has an external surface spread of flame Class 0 and there is no height restriction (see section 7).

Condensation — the system can contribute to limiting the risk of interstitial and surface condensation (see section 9).

Durability — the design life of the system under typical conditions has been considered as part of this assessment (see section 11).

The BBA has awarded this Agrément Certificate to the company named above for the system described herein. This system has been assessed by the BBA as being fit for its intended use provided it is installed, used and maintained as set out in this Certificate.

On behalf of the British Board of Agrément

Chris Hunt
Head of Approvals — Physics

Greg Cooper
Chief Executive

Date of First issue: 12 November 2009

Originally certificated on 9 July 1990

Certificate amended on 18 November 2010 with removal of height restriction and addition to section 7.2.

The BBA is a UKAS accredited certification body — Number 113. The schedule of the current scope of accreditation for product certification is available in pdf format via the UKAS link on the BBA website at www.bbacerts.co.uk

Readers are advised to check the validity and latest issue number of this Agrément Certificate by either referring to the BBA website or contacting the BBA direct.

British Board of Agrément
Bucknalls Lane
Garston, Watford
Herts WD25 9BA

©2009

tel: 01923 665300
fax: 01923 665301
e-mail: mail@bba.star.co.uk
website: www.bbacerts.co.uk

Regulations

In the opinion of the BBA, the Rockshield LW External Wall Insulation System if used in accordance with the provisions of this Certificate, will meet or contribute to meeting the relevant requirements of the following Building Regulations:



The Building Regulations 2000 (as amended) (England and Wales)

Requirement: A1	Loading
Comment:	The system can sustain and transmit wind loads to substrate wall. See section 6.1 of this Certificate.
Requirement: B4(1)	External fire spread
Comment:	The system is classified Class 0 and therefore can meet this Requirement. See sections 7.1 and 7.2 of this Certificate.
Requirement: C2(b)	Resistance to moisture
Comment:	The system provides a degree of protection against rain ingress. See sections 3.4 and 8.1 to 8.3 of this Certificate.
Requirement: C2(c)	Resistance to moisture
Comment:	The system contributes to minimising the risk of interstitial and surface condensation. See sections 9.1 and 9.3 of this Certificate.
Requirement: L1(a)(i)	Conservation of fuel and power
Comment:	The system can contribute to meeting this requirement. See sections 5.3 to 5.5 of this Certificate.
Requirement: Regulation 7	Materials and workmanship
Comment:	The system is acceptable. See sections 11.1 and 11.2 and the <i>Installation</i> part of this Certificate.



The Building (Scotland) Regulations 2004 (as amended)

Regulation: 8(1)(2)	Fitness and durability of materials and workmanship
Comment:	The system can contribute to a construction meeting this Regulation. See sections 10, 11.1 and 11.2 and the <i>Installation</i> part of this Certificate.
Regulation: 9	Building standards – construction
Standard: 1.1	Structure
Comment:	The system can sustain and transmit wind loads to the substrate wall. See section 6.1 of this Certificate.
Standard: 2.6	Spread to neighbouring buildings
Comment:	The system has a Class 0 surface and can satisfy this Standard, with reference to clauses 2.6.4 ⁽¹⁾⁽²⁾ . See section 7.1 of this Certificate.
Standard: 2.7	Spread on external walls
Comment:	The system incorporates materials which would not be classed as ‘non-combustible’ as defined in this Standard, with reference to clause 2.7.1 ⁽¹⁾⁽²⁾ . See section 7.2 of this Certificate.
Standard: 3.10	Precipitation
Comment:	Walls insulated with the system will provide a degree of protection against rain ingress satisfying this Standard, with reference to clause 3.10.1 ⁽¹⁾⁽²⁾ and 3.10.2 ⁽¹⁾⁽²⁾ . See sections 3.4 and 8.1 to 8.3 of this Certificate.
Standard: 3.15	Condensation
Comment:	Walls insulated with the system contribute to minimising the risk of interstitial and surface condensation satisfying this Standard, with reference to clauses 3.15.1 ⁽¹⁾ , 3.15.4 ⁽¹⁾ and 3.15.5 ⁽¹⁾ . See sections 9.2 and 9.3 of this Certificate.
Standard: 6.1(a)(b)	Carbon dioxide emissions
Standard: 6.2	Buildings insulation envelope
Comment:	The system can contribute to satisfying these Standards, with reference to clauses (or parts of) 6.1.1 ⁽¹⁾ , 6.1.2 ⁽¹⁾⁽²⁾ , 6.1.3 ⁽²⁾ , 6.1.5 ⁽²⁾ , 6.1.6 ⁽¹⁾ , 6.2.1 ⁽¹⁾⁽²⁾ , 6.2.3 ⁽¹⁾⁽²⁾ , 6.2.4 ⁽²⁾ , 6.2.6 ⁽¹⁾⁽²⁾ , 6.2.7 ⁽¹⁾⁽²⁾ , 6.2.8 ⁽²⁾ , 6.2.9 ⁽¹⁾⁽²⁾ , 6.2.10 ⁽¹⁾⁽²⁾ , 6.2.11 ⁽¹⁾ , 6.2.12 ⁽²⁾ and 6.2.13 ⁽¹⁾ . See sections 5.3 to 5.5 of this Certificate. (1) Technical Handbook (Domestic). (2) Technical Handbook (Non-Domestic).



The Building Regulations (Northern Ireland) 2000 (as amended)

Regulation: B2	Fitness of materials and workmanship
Comment:	The system is acceptable. See sections 11.1 and 11.2 and the <i>Installation</i> part of this Certificate.
Regulation: B3(2)	Suitability of certain materials
Comment:	The system is acceptable. See section 10 of this Certificate.
Regulation: C4(b)	Resistance to ground moisture and weather
Comment:	Walls insulated with the system provide a degree of protection against rain ingress and contribute to satisfy this Regulation See sections 3.4 and 8.1 to 8.3 of this Certificate.
Regulation: C5	Condensation
Comment:	Walls insulated with the system contribute to minimising the risk of interstitial and surface condensation satisfying this Regulation. See section 9.3 of this Certificate.
Regulation: D1	Stability
Comment:	The system can sustain and transmit wind loads to the substrate wall. See section 6.1 of this Certificate.

Regulation:	E5(a)	External fire spread
Comment:	The system has a Class 0 surface and can satisfy this Regulation. See sections 7.1 and 7.2 of this Certificate.	
Regulation:	F2(a)(i)	Conservation measures
Regulation:	F3	Target carbon dioxide Emissions Rate
Comment:	The system can contribute to satisfying these Regulations. See sections 5.3 to 5.5 of this Certificate.	

Construction (Design and Management) Regulations 2007

Construction (Design and Management) Regulations (Northern Ireland) 2007

Information in this Certificate may assist the client, CDM co-ordinator, designer and contractors to address their obligations under these Regulations.

See section: *2 Delivery and site handling (2.2)*

Non-regulatory Information

NHBC Standards 2008

NHBC accepts the use of the Rockshield LW External Wall Insulation System, when installed and used in accordance with this Certificate, in relation to *NHBC Standards, Chapter 6.9 Curtain walling and cladding*.

General

The Rockshield LW External Wall Insulation System, is applied to the outside of external walls of masonry, dense or no-fines concrete construction.

The insulation product is manufactured at the Certificate holder's premises in Pencoed, Bridgend, Mid-Glamorgan, CF35 6NY.

Technical Specification

1 Description

1.1 The Rockshield LW External Wall Insulation System (see Figure 1) comprises:

- Rockshield Adhesive Mortar — a mixture of white Portland cement, quartz sand and other additives supplied as a powder to which clean water is added
- mineral wool insulation slabs — Rockwool Dual Density 1000 mm x 500 mm in a range of thicknesses between 50 mm and 200 mm with an average density of 110 kg·m⁻³. Rockwool High Density 1000 x 500 mm in a range of thicknesses between 30 mm and 40 mm, with a minimum density of 126 kg·m⁻³ and a minimum cross-breaking strength of 25 kN·m⁻². The slabs are manufactured using conventional techniques and incorporate a phenolic resin binder and a mineral oil water repellent
- mechanical fixings — polypropylene mechanical fixings, approved by the Certificate holder
- Rockshield Light Plaster — a mixture of white Portland cement, quartz sand
- and other additives supplied as a powder to which clean water is added
- Rockshield Reinforcement Mesh — a one metre wide mesh of multi-stranded glass fibres with a polymer coating and a nominal weight of 160 g·m⁻²
- Rockshield Masonry Sealer — an emulsion containing fine quartz grains used as a bonding aid and pre-coat
- Rockshield Silcoplast finish — a silicone bonded textured plaster supplied as a paste in three grades, coarse 1.5 mm, 2.5 mm or 3.5 mm grain size. It is available in a range of colours
- Rockshield Colorsil — a micro-porous silicone-based façade paint used as a decorative finish
- ancillary materials include:
 - Rockshield Socket Profile — a metal trimming strip with a recessed water drip used as the base profile
 - Rockshield NB Edge Profile — a plastic meshed corner profile used as reinforcement for external corners and edges
 - Rockshield Sealing Tape — a self-adhesive compressed PVC-U foam tape.

Figure 1 Rockshield LW External Wall Insulation System

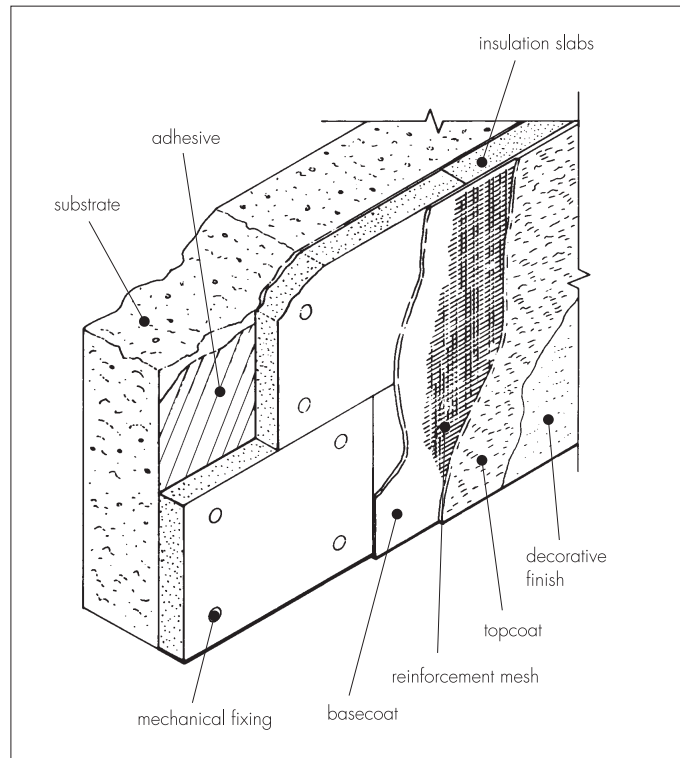

1.2 The insulation slabs are bonded to the external surfaces of walls using the adhesive and secured with mechanical fixings at the average frequency of eight fixings per square metre depending on individual specifications (see Figure 2). The basecoat is trowel applied to the insulation to a minimum thickness of approximately 8 mm to 12 mm and the reinforcement mesh is embedded immediately. Allowing 2 days drying time for the basecoat, a masonry sealer is then applied, then the topcoat is trowel applied to a thickness of approximately 1.5 mm to 3.5 mm depending on the grain size used.

Figure 2 Typical section at base level

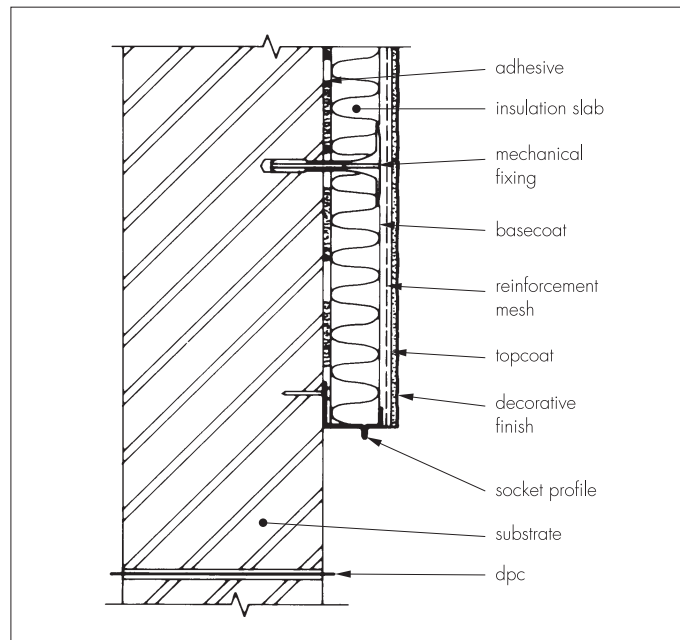

1.3 All components are subject to routine in-factory quality control.

2 Delivery and site handling

2.1 The insulation is delivered to site wrapped in polythene. Each pack carries the product identification and batch numbers.

2.2 Components are delivered to the site in bags and quantities as listed in Table 1. Each bag carries the BBA identification mark incorporating the number of this Certificate.

Table 1 Component supply details

Component	Quantity and package
Adhesive	25 kg bag
LW Basecoat	20 kg bag
Topcoat	25 kg tub
Decorative paint	15 kg tub
Masonry sealer	16 litre container
Reinforcement mesh	50 metre rolls by 1 metre wide
Mechanical fixings	Boxed by manufacturer

2.3 The insulation should be stored on a firm, clean, level base, off the ground and under cover until required for use. Care must be taken when handling the insulation to avoid damage.

2.4 The renders must be stored in dry conditions, off the ground, and be protected from moisture.

2.5 The Rockshield Silcoplast Finish and Colorsil paint should be stored in a safe area, under cover and protected from excessive heat and frost at all times.

Assessment and Technical Investigations

The following is a summary of the assessment and technical investigations carried out on the Rockshield LW External Wall Insulation System.

Design Considerations

3 General

3.1 The Rockshield LW External Wall Insulation System is effective in reducing the thermal transmittance (U value) of the walls of new and existing buildings. It is essential that the detailing techniques specified in this Certificate are carried out to a high standard if the ingress of water into the insulation is to be avoided and the full thermal benefit obtained from the system.

3.2 The system will improve the weather resistance of a wall and provide a decorative finish. However, it may be installed only where other routes for moisture penetration have been dealt with separately and where there are no signs of dampness on the inner surface of the wall, other than those caused solely by condensation. The system can be used to overcome condensation associated with the internal wall surface.

3.3 Existing buildings, subject to national Building Regulations, should have wall surfaces in accordance with section 1.2 *Site survey and preliminary work* in the *Installation* part of this Certificate.

3.4 New walls subject to national Building Regulations should be constructed in accordance with the relevant recommendations of:



- BS 5628-3 : 2005. In particular Clause 5.5.2 *Rain penetration*, of the Code of Practice should be followed in that the designer should select a construction appropriate to the local wind-driven rain index, paying due regard to the design detailing, workmanship and materials to be used
- BS 8000-3 : 2001.

3.5 Other walls, not subject to regulatory requirements should also be built in accordance with the requirements in section 3.4.

3.6 When using the system, consideration must be given to the overall design to minimise the risk of condensation and the recommendations of BS 5250 : 2002 should be followed.

4 Practicability of installation

The system should only be installed by installers who have been trained and approved by the Certificate holder (see section 1.4).

5 Thermal performance

5.1 Calculations of thermal transmittance (U value) should be carried out in accordance with BS EN ISO 6946 : 2007 and BRE report (BR 443 : 2006) *Conventions for U-value calculations*, using the manufacturer's declared thermal conductivity ($\lambda_{90/90}$ value) of $0.036 \text{ W}\cdot\text{m}^{-1}\cdot\text{K}^{-1}$ for the insulations.

5.2 The U value of a completed wall will depend on the selected insulation thickness and fixing method, the insulating value of the substrate masonry and its internal finish. Calculated U values for example constructions are given in Table 2.

Table 2 U values for Rockshield EWIS construction

Insulation thickness (mm)	U value ($\text{W}\cdot\text{m}^{-2}\cdot\text{K}^{-1}$)	
	HD Rockwool	DD Rockwool
30	0.72	–
40	0.60	–
50	0.51	0.51
60	–	0.45
70	–	0.40
80	–	0.36
90	–	0.33
100	–	0.30
110	–	0.28
120	–	0.26
130	–	0.24
140	–	0.22
150	–	0.21
160	–	0.20
170	–	0.19
180	–	0.18
190	–	0.17
200	–	0.16



5.3 When considering insulation requirements, designers should refer to the detailed guidance contained in the documents supporting the national Building Regulations. The U values shown in Table 2 indicate that the system can enable a wall to achieve typical design U values (as shown in Tables 3 and 4) referred to in those supporting documents.

Table 3 Typical design U values for walls — England and Wales, and Northern Ireland

Design U value ($\text{W}\cdot\text{m}^{-2}\cdot\text{K}^{-1}$)	Construction type
0.30	Mean for new extensions ⁽¹⁾
0.35	'Notional' mean in SAP and SBEM and limit mean for new-build
0.35	Mean for replacement, renovated and retained walls and non-domestic consequential improvements ⁽¹⁾
0.70	Individual limit for new-build and flexible approaches ⁽¹⁾

(1) Alternative/flexible approaches are described in the relevant documents supporting the national Building Regulations.

Table 4 Typical design U values for walls — Scotland

Design U value ($\text{W}\cdot\text{m}^{-2}\cdot\text{K}^{-1}$)	Construction type
0.20	'Notional' mean for dwellings in SAP and the 'simplified' approach: – solid fuel, package 6
0.25	– other fuels, packages 1-5
0.27	Mean for new extensions, conversions, alterations ⁽¹⁾
0.27	Mean for stand-alone buildings less than 50 m^2 .
0.30	'Notional' mean for non-domestic in SBEM and limit mean for new-build and stand-alone buildings of 50 m^2 or more
0.70	Individual limit for new-build, extensions, conversions, alterations, reconstructions and stand-alone buildings less than 50 m^2 .

(1) Alternative/flexible approaches are described in the relevant documents supporting the national Building Regulations.

5.4 For new buildings, walls with U values lower than (or the same as, for dwellings in Scotland) the relevant 'notional' value specified in Table 3 or 4 will contribute to a building meeting its Target Emission Rate. Walls with higher U values will require additional energy saving measures in the building envelope and/or services. For existing buildings, walls should be designed not to exceed the relevant U value in Table 3 or 4.

5.5 The system can maintain, or contribute to maintaining, continuity of thermal insulation around openings and at junctions between external walls and other building elements. Details shown in Figure 2 and Figure 5 of this Certificate will allow use of the default psi values for Accredited Construction details in Emission Rate calculations to SAP 2005 or the Simplified Building Energy Model (SBEM). Detailed guidance in this respect and on limiting heat loss by air infiltration can be found in:

England and Wales — TSO 2002 publication *Limiting thermal bridging and air leakage: Robust construction details for dwellings and similar buildings* or Accredited Construction Details (version 1.0).

Scotland — Accredited Construction Details (Scotland) or, for existing buildings, BR 262 *Thermal insulation: avoiding risks* 2002

Northern Ireland — Accredited Construction Details (version 1.0).

6 Strength and stability



6.1 When installed on suitable walls, the system can adequately transfer self weight, and negative and positive (suction and pressure) wind loads to the wall.

6.2 The ultimate wind load to be resisted by the system should be determined by calculating the wind load in accordance with BS EN 1991-1-4 : 2005 or BS 6399-2 : 1997 and multiplying by a load factor of 1.5 (as recommended in EN 1990 : 2002). Special consideration should be given to locations with high wind-load pressure coefficients (additional fixings or adhesive may be necessary).

6.3 Assessment of structural performance for individual installations should be carried out by a suitably qualified engineer or other appropriately qualified person to confirm that the substrate wall has adequate strength to resist the additional loads that may be applied as a result of installing the system ignoring any positive contribution that may occur from the system and that the proposed system and associated fixing layout provides adequate resistance to negative wind loads.

7 Behaviour in relation to fire



7.1 The insulation is classified as non combustible to BS EN 13501-1 : 2007. The external surfaces of the system are classified as Class 0 or 'low risk' as defined in the documents supporting the national Building Regulations. The system, therefore, may be used in subject to the provisions of:

England and Wales — Approved Document B, paragraph 8.4 volume 1 and paragraphs 12.5 and 12.6 volume 2 (see also Diagram 40)

Scotland — Mandatory Standards 2.6 and 2.7, clauses 2.6.1⁽¹⁾⁽²⁾ to 2.6.5⁽¹⁾⁽²⁾, 2.6.6⁽²⁾, 2.6.7⁽²⁾, 2.7.1⁽¹⁾⁽²⁾ and 2.7.2⁽²⁾ respectively and Annexes 2.C⁽¹⁾ and 2.E⁽²⁾

(1) Technical Handbook (Domestic).

(2) Technical Handbook (Non-Domestic).

Northern Ireland — Technical Booklet E, paragraph 4.3 (see also Diagram 4.1).

7.2 The behaviour in fire of external wall insulation is the subject of recommendations by the Building Research Establishment which, for this system, makes no restriction on the height of building to be treated. The system complies with BS 8414-1 : 2002.

8 Rain penetration



8.1 The system will provide a degree of protection against rain ingress. However, care should be taken to ensure that walls are adequately weathertight prior to its application.

8.2 Designers and installers should take particular care in detailing around openings, penetrations and movement joints to minimise the risk of rain ingress.

8.3 Guidance in BS 5628-3 : 2005, Table 11, indicates that externally insulated single leaf masonry walls (minimum 90 mm thick) are acceptable in exposure categories up to 'severe'.

9 Condensation

Surface condensation



9.1 Walls will limit the risk of surface condensation adequately when the thermal transmittance (U value) does not exceed $0.7 \text{ W}\cdot\text{m}^{-2}\cdot\text{K}^{-1}$ at any point and the junctions with other elements are designed in accordance with the relevant requirements of the publications referred to in section 5.



9.2 Walls and ceilings will adequately limit the risk of surface condensation when the thermal transmittance (U value) does not exceed $1.2 \text{ W}\cdot\text{m}^{-2}\cdot\text{K}^{-1}$ at any point. Guidance may be obtained from Section 8 of BS 5250 : 2002 and BRE report (BR 262 : 2002).

Interstitial condensation



9.3 Walls incorporating the system will adequately limit the risk of interstitial condensation when they are designed and constructed in accordance with BS 5250 : 2002 (Section 8 and Annex D).

10 Maintenance



Regular checks should be made on the installed system, particularly at joints, to ensure that ingress of water does not occur. This includes checks on joints in the system and on any penetrations through the system, such as those caused by external plumbing fittings, to identify leakage of rainwater into the system, enabling steps to be taken to correct the defects. Necessary repairs should be carried out immediately.

11 Durability



11.1 The system should remain effective for at least 30 years, provided any damage to the surface finish is repaired immediately, and regular maintenance is undertaken. See section 10.

11.2 The results of accelerated ageing tests in accordance with MOAT No 22 : 1988 indicate that the system is durable. The system should remain effective for at least 30 years, provided any damage to the surface finish is repaired immediately, and regular maintenance is undertaken including checks on joints in the system and on external plumbing fittings to identify leakage of rainwater into the system, enabling steps to be taken to correct the defects.

11.3 The finishes may become soiled in time, the rate depending on locality.

11.4 Tests conducted by the BBA indicate that when used in situations where walls are exposed but have some protection, eg walls of private dwellings and walls of communal dwellings above ground-floor level, the system has adequate resistance to possible damage. In other situations, eg walls of public buildings at ground-floor level, precautions may be required to reduce the risk of damage. Further information may be obtained from BRE Current Paper CP 6: 1981 *Assessment of external walls — Hard Body Impact Resistance*.

Installation

12 Site survey and preliminary work

12.1 A pre-installation survey of the property is carried out to determine suitability for treatment and any repairs necessary to the building structure before application of a system. A specification is prepared for each elevation of the building indicating:

- the position of beads
- detailing around windows, doors and at eaves
- dpc level
- exact position of expansion joints
- areas where flexible sealants must be used
- any alterations to external plumbing
- where required, the position of fire barriers.

12.2 The survey should include tests conducted on the walls of the building by the Certificate holder or their approved suppliers to determine the pull-out resistance of the proposed mechanical fixings. An assessment and recommendation is made on the type and number of fixings required to withstand the building's expected wind loading based on calculations using the test data, the relevant wind speed data for the site, and in the absence of a formal requirement, a safety factor of 3 should be used.

12.3 All necessary repairs to the building structure are completed before installation of the system is started.

12.4 Surfaces should be sound, clean, and free from loose material. The flatness of surfaces must be checked; this may be achieved using a straight edge spanning the storey height. Any excessive irregularities, ie greater than 10 mm, must be made good prior to installation to ensure that the insulation boards are installed with a smooth, in-plane finished surface.

12.5 Where surfaces are covered with an existing rendering it is essential that the bond between the background and the render is adequate. All loose areas should be hacked off and reinstated.

12.6 On existing buildings, purpose-made sills must be fitted to extend beyond the finished face of the system by a minimum of 30 mm. New buildings should incorporate suitably deep sills.

12.7 It is recommended that external plumbing be removed and alterations made to underground drainage, where appropriate, to accommodate repositioning on the finished face of the system.

12.8 New buildings should be of sound masonry or dense concrete construction.

12.9 Internal wet work, eg screeding or plastering, should be completed and allowed to dry prior to the application of the system.

13 Procedure

General

13.1 Application is carried out in accordance with the Certificate holder's current installation instructions.

13.2 Application of coating materials must not be carried out at temperatures below 5°C or above 30°C, nor if exposure to frost is likely, and the coating must be protected from rapid drying. Weather conditions should therefore be monitored to ensure correct curing conditions.

13.3 All rendering should be in accordance with the relevant recommendations of BS EN 13914-1 : 2005

Positioning and securing insulation boards

13.4 The base profile is secured to the external wall above the damp-proof course using the approved profile fixings at approximately 300 mm centres.

13.5 The adhesive is prepared for use by mixing the contents of each 25 kg bag with approximately six litres of water using an electrically driven paddle mixer to give a smooth, workable consistency. Care should be taken not to over-mix.

13.6 The adhesive is applied to the back of the slabs by either a comb to achieve a full bond, or as dabs for an uneven background.

13.7 The insulation slabs should be pressed firmly to the substrate immediately after application of the adhesive. Any delay may result in a weak bond.

13.8 The first run of insulation is positioned on the base profile. Holes are drilled into the substrate to a minimum depth of 50 mm through the insulation at 150 mm from each corner of each slab and at positions that will allow a minimum of eight fixings per square metre. The mechanical fixings are inserted and tapped firmly into place, securing the insulation to the substrate. Subsequent rows of slabs are positioned so that the joints are staggered and overlapped at the building corners (see Figure 3).

Figure 3 Arrangement of insulation slabs

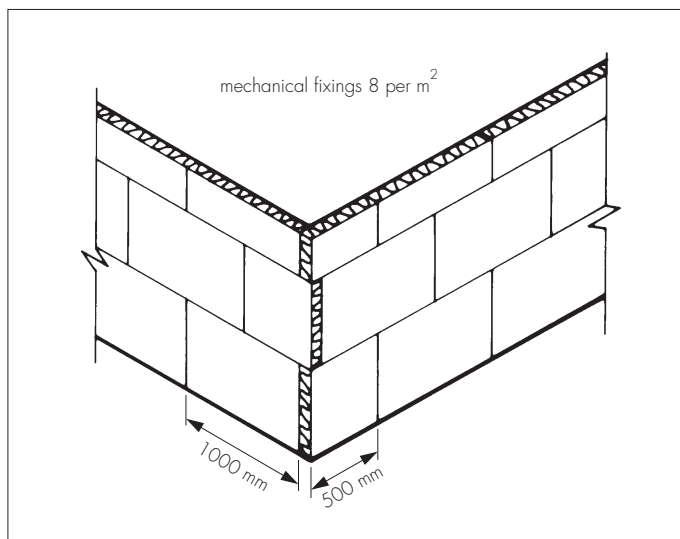

13.9 Care must be taken to ensure that all slab edges are butted tightly together, and alignment should be checked as work proceeds.

13.10 To fit around details such as doors and windows, insulation slabs may be cut with a sharp knife or a fine-tooth saw. If required, purpose-made window sills are fitted. They are designed to prevent water ingress and incorporate drips to shed water clear of the system.

13.11 Installation continues until the whole wall is completely covered including, where appropriate, the building soffits.

Movement joints

13.12 Movement joints in the substrate must be continued through the system. The joint detail using purpose-made metal trims is illustrated in Figure 4.

Figure 4 Vertical movement joint

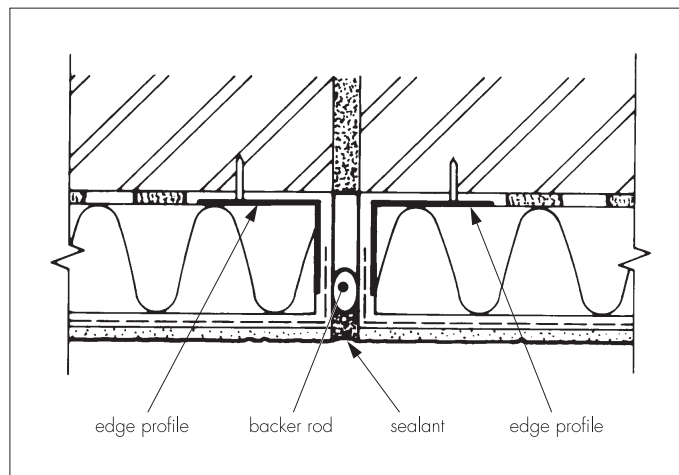

Reinforcing

13.13 The basecoat is prepared by mixing the contents of each 20 kg bag with approximately six litres of cold, clean water using the same method as for the adhesive.

13.14 The basecoat render is trowel applied to the surface of the dry insulation to a minimum thickness of 8 mm and a maximum thickness of 12 mm. The mesh is bedded immediately into the basecoat with 100 mm laps at joints. Additional pieces of reinforcing mesh are used diagonally at the corners of openings, as shown in Figure 5.

Figure 5 Additional reinforcement at openings

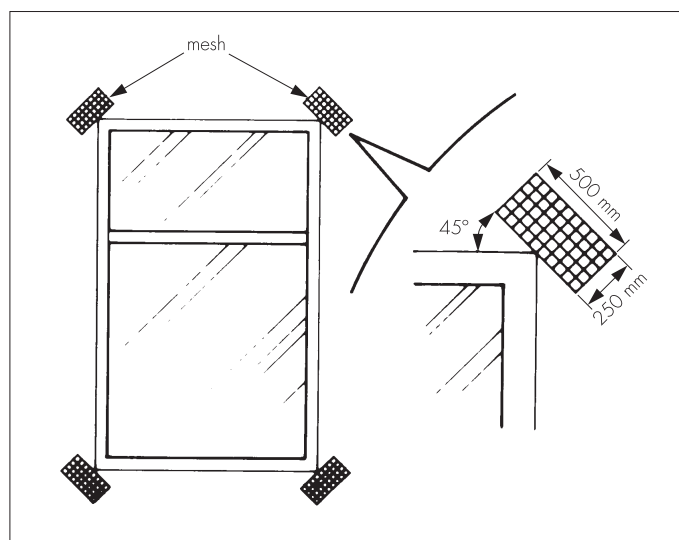

13.15 Prior to the render coat, a bead of clear silicone rubber mastic is gun applied at window and door frames, overhanging eaves, gas and electric meter boxes, wall vents or where the render abuts any other building material or surface.

13.16 Angle beads are fixed to all building corners and to door and window heads and jambs.

13.17 Expansion beads are fixed vertically in agreed positions. These beads are positioned at approximately seven metre centres along a building, the centres depending on the individual requirements of each job.

13.18 Stop beads are positioned vertically, eg at party wall positions where the adjoining house does not require treatment.

Rendering and finishing

13.19 The drying period of any render will depend on weather conditions; however, the basecoat must be left to harden for at least two days before the keying agent is applied by roller or brush. The keying agent is allowed to dry before application of the topcoat. The topcoat is ready mixed in 25 kg tubs. The topcoat is trowel applied to thicknesses of 1.5 mm, 2.5 mm or 3.5 mm depending on specification

13.20 To prevent the finish from drying too rapidly, continuous surfaces should be completed without a break.

13.21 Depending on weather conditions, the topcoat should be allowed to dry for at least two days before application of Colorsil decorative finish.

13.22 At the tops of walls the system should be protected by an adequate overhang or by an adequately sealed purpose-made flashing (see Figure 6).

Figure 6 Roof eaves detail

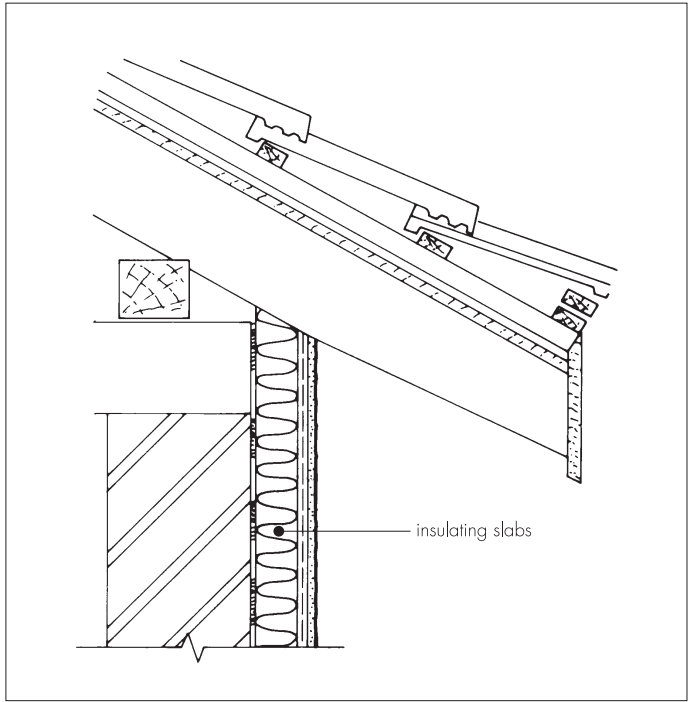

13.23 Care should be taken in the detailing of the system around openings and projections (see Figures 7, 8, 9 and 10).

Figure 7 Insulated window detail

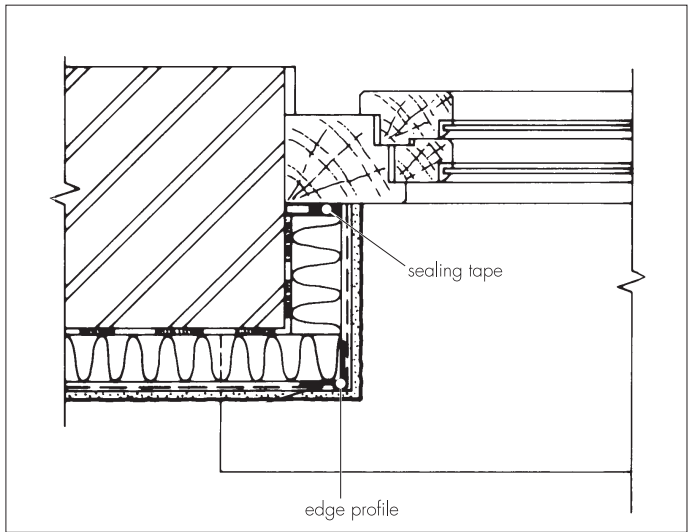

Figure 8 Uninsulated window reveal detail

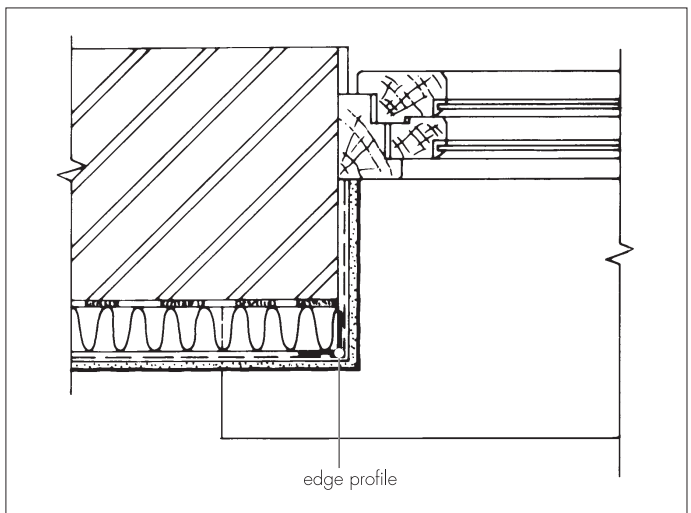

Figure 9 Window head detail

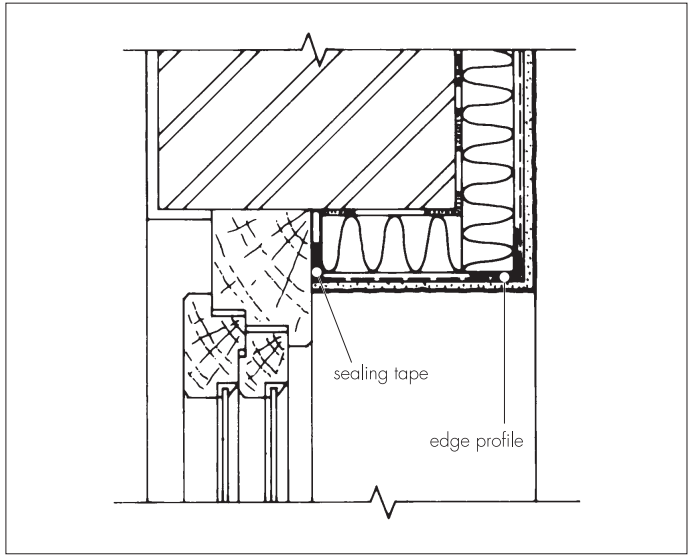
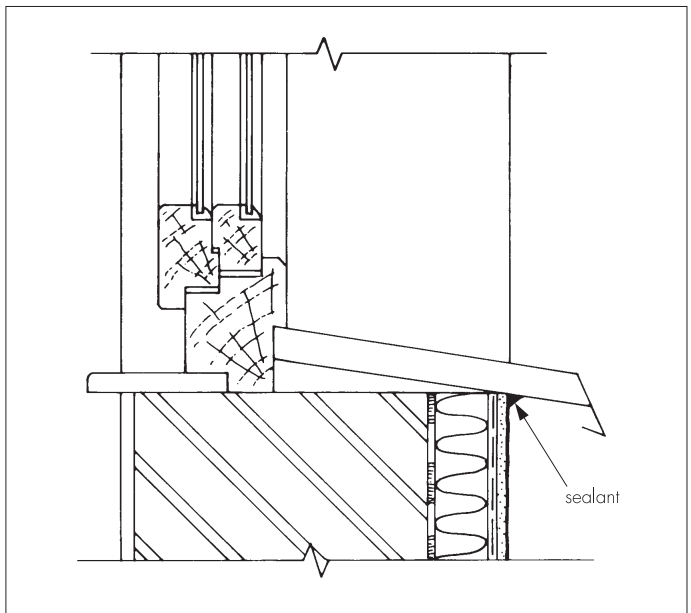

Figure 10 Window sill detail



13.24 On completion of the installation, external fittings, eg rainwater goods, are refixed through the system into the substrate.

14 General

Approved installers

14.1 Application of the system, within the context of this Certificate, is carried out by approved installers, an approved installer being a firm which:

- is employing operatives who have been trained and approved by the Certificate holder to install the system and who have been issued with the appropriate training cards by them
- has undertaken to comply with the Certificate holder's application procedure, which contains the requirement for each application team to include at least one member with a training card, and
- is subject to supervision by the Certificate holder, including site inspections.

14.2 Firms approved by the Certificate holder may also be approved to install the system under the BBA's Assessment and Surveillance Scheme for Installers of External Wall Insulation Systems. In addition to the requirements given in section 14.1, these installers will be subject to site and office inspections by the BBA prior to approval and while they remain approved.

15 Tests

15.1 Tests were carried out on the Rockshield LW External Wall Insulation System in accordance with MOAT No 22 : 1998 to determine:

- component characterisation
- flexural and compressive strength of renders
- density of slab
- heat/spray cycling
- resistance to freeze/thaw
- impact resistance
- water absorption of render
- water vapour permeability.

15.2 An examination was made of data relating to:

- non-combustibility tests to BS 476-4 : 1970
- fire propagation tests to BS 476-6 : 1989
- surface spread of flame tests to BS 476-7 : 1997
- pull-out strength of fixings
- durability of finish
- thermal conductivity to BS EN 12667 : 2001 .

16 Investigations

16.1 The manufacturing process, the methods adopted for quality control of manufactured and brought-in components, and details of the quality and composition of materials used, was examined.

16.2 An assessments into the risk of interstitial condensation was undertaken.

16.3 The practicability of installation and the effectiveness of detailing techniques were examined.

16.4 Visits were made to existing sites to assess the performance of the product in use.

Bibliography

- BS 476-4 : 1970 *Fire tests on building materials and structures — Non-combustibility test for materials*
- BS 476-6 : 1989 *Fire tests on building materials and structures — Method of test for fire propagation for products*
- BS 476-7 : 1997 *Fire tests on building materials and structures — Method of test to determine the classification of the surface spread of flame of products*
- BS 5250 : 2002 *Code of practice for control of condensation in buildings*
- BS 5628-3 : 2005 *Code of practice for the use of masonry — Materials and components, design and workmanship*
- BS 6399-2 : 1997 *Loading for buildings — Code of practice for wind loads*
- BS 8000-3 : 2001 *Workmanship on building sites — Code of practice for masonry*
- BS 8414-1 : 2002 *Fire performance of external cladding systems — Test methods for non-loadbearing external cladding systems applied to the face of a building*
- BS EN 12667 : 2001 *Thermal performance of building materials and products — Determination of thermal resistance by means of guarded hot plate and heat flow meter methods — Products of high and medium thermal resistance*
- BS EN 13501-1 : 2007 *Fire classification of construction products and building elements. Classification using test data from reaction to fire tests*
- BS EN 13914-1 : 2005 *Design, preparation and application of external rendering and internal plastering — External rendering*
- BS EN ISO 6946 : 1997 *Building components and building elements — Thermal resistance and thermal transmittance — Calculation method*
- MOAT No 22 : 1988 *UEAtc Directives for the Assessment of External Insulation Systems for Walls (Expanded Polystyrene Insulation Faced with a Thin Rendering)*

17 Conditions

17.1 This Certificate:

- relates only to the product/system that is named and described on the front page
- is granted only to the company, firm or person named on the front page — no other company, firm or person may hold or claim any entitlement to this Certificate
- is valid only within the UK
- has to be read, considered and used as a whole document — it may be misleading and will be incomplete to be selective
- is copyright of the BBA
- is subject to English law.

17.2 Publications and documents referred to in this Certificate are those that the BBA deems to be relevant at the date of issue or re-issue of this Certificate and include any: Act of Parliament; Statutory Instrument; Directive; Regulation; British, European or International Standard; Code of Practice; manufacturers' instructions; or any other publication or document similar or related to the aforementioned.

17.3 This Certificate will remain valid for an unlimited period provided that the product/system and the manufacture and/or fabrication including all related and relevant processes thereof:

- are maintained at or above the levels which have been assessed and found to be satisfactory by the BBA
- continue to be checked as and when deemed appropriate by the BBA under arrangements that it will determine
- are reviewed by the BBA as and when it considers appropriate.

17.4 In granting this Certificate, the BBA is not responsible for:

- the presence or absence of any patent, intellectual property or similar rights subsisting in the product/system or any other product/system
- the right of the Certificate holder to manufacture, supply, install, maintain or market the product/system
- individual installations of the product/system, including the nature, design, methods and workmanship of or related to the installation
- the actual works in which the product/system is installed, used and maintained, including the nature, design, methods and workmanship of such works.

17.5 Any information relating to the manufacture, supply, installation, use and maintenance of this product/system which is contained or referred to in this Certificate is the minimum required to be met when the product/system is manufactured, supplied, installed, used and maintained. It does not purport in any way to restate the requirements of the Health & Safety at Work etc Act 1974, or of any other statutory, common law or other duty which may exist at the date of this Certificate; nor is conformity with such information to be taken as satisfying the requirements of the 1974 Act or of any statutory, common law or other duty of care. In granting this Certificate, the BBA does not accept responsibility to any person or body for any loss or damage, including personal injury, arising as a direct or indirect result of the manufacture, supply, installation, use and maintenance of this product/system.

