

Icopal Limited

Barton Dock Road
Stretford
Manchester M32 0YL

Tel: 0161-865 4444 Fax: 0161-864 8433
e-mail: market.uk@icopal.com
website: www.icopal.co.uk



Agrément Certificate
91/2618
Product Sheet 4

ICOPAL POUR AND ROLL ROOF WATERPROOFING

ICOPAL VAPOUR CONTROL LAYERS

PRODUCT SCOPE AND SUMMARY OF CERTIFICATE

This Certificate relates to Icopal Vapour Control Layers, a range of elastomeric bitumen sheeting with aluminium foils, for use as high-resistance vapour control layers on built-up felt roofing systems and other roof waterproofing or insulation systems.

AGRÉMENT CERTIFICATION INCLUDES:

- factors relating to compliance with Building Regulations where applicable
- factors relating to additional non-regulatory information where applicable
- independently verified technical specification
- assessment criteria and technical investigations
- design considerations
- installation guidance
- regular surveillance of production
- formal three-yearly review.

KEY FACTORS ASSESSED

Resistance to water and water vapour — the products provide an effective control to the passage of liquid water and water vapour (see section 5).

Properties in relation to fire — in the opinion of the BBA, the products, when used in a suitable specification, will enable a roof to be unrestricted under Building Regulations (see section 6).

Resistance to wind uplift — when correctly specified, the system will resist the effects of any wind suction likely to occur in practice (see section 7).

Resistance to foot traffic — the products will accept the limited foot traffic and loads associated with installation and maintenance of the products without damage (see section 8).

Durability — under normal service conditions the products will provide a durable waterproof covering with a service life of at least 20 years (see section 10).

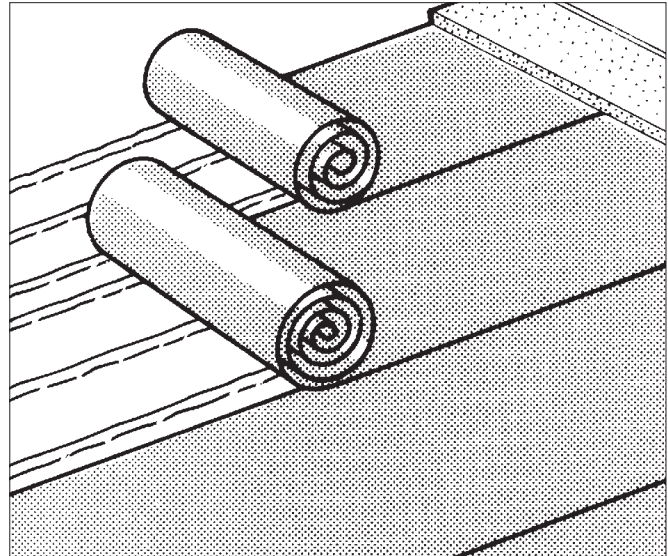

The BBA has awarded this Agrément Certificate to the company named above for the products described herein. These products have been assessed by the BBA as being fit for their intended use provided they are installed, used and maintained as set out in this Certificate.

On behalf of the British Board of Agrément

Simon Wroe
Head of Approvals — Materials

Greg Cooper
Chief Executive

Date of First issue: 11 February 2009

The BBA is a UKAS accredited certification body — Number 1113. The schedule of the current scope of accreditation for product certification is available in pdf format via the UKAS link on the BBA website at www.bbacerts.co.uk

Readers are advised to check the validity and latest issue number of this Agrément Certificate by either referring to the BBA website or contacting the BBA direct.

British Board of Agrément
Bucknalls Lane
Garston, Watford
Herts WD25 9BA

©2009

tel: 01923 665300
fax: 01923 665301
e-mail: mail@bba.star.co.uk
website: www.bbacerts.co.uk

Regulations

In the opinion of the BBA, Icopal Vapour Control Layers, if used in accordance with the provisions of this Certificate, will meet or contribute to meeting the relevant requirements of the following Building Regulations:



The Building Regulations 2000 (as amended) (England and Wales)

Requirement:	C2(c)	Resistance to moisture
Comment:		The products can contribute to enabling a roof to satisfy the requirements of this Regulation. See section 5 of this Certificate.
Requirement:	Regulation 7	Materials and workmanship
Comment:		The products are acceptable. See section 10 and the <i>Installation</i> part of this Certificate



The Building (Scotland) Regulations 2004 (as amended)

Regulation:	8(1)(2)	Fitness and durability of materials and workmanship
Comment:		The products can satisfy the requirements of this Regulation. See sections 9, 10 and the <i>Installation</i> part of this Certificate.
Regulation:	9	Building standards – construction
Standard:	3.15	Condensation
Comment:		The products can contribute to enabling a roof to satisfy this Standard, with reference to clauses 3.15.1 ⁽¹⁾ , 3.15.3 ⁽¹⁾ , 3.15.5 ⁽¹⁾ and 3.15.6 ⁽¹⁾ . See section 5 of this Certificate.
Regulation:	12	Building standards – conversions
Comment:		All comments given for these products under Regulation 9, also apply to this Regulation, with reference to clause 0.12.1 ⁽¹⁾⁽²⁾ and Schedule 6 ⁽¹⁾⁽²⁾ . (1) Technical Handbook (Domestic). (2) Technical Handbook (Non-Domestic).



The Building Regulations (Northern Ireland) 2000 (as amended)

Regulation:	B2	Fitness of materials and workmanship
Comment:		The products are acceptable. See section 10 and the <i>Installation</i> part of this Certificate.
Regulation:	B3(2)	Suitability of certain materials
Comment:		The products do not normally require maintenance. See section 9 of this Certificate.
Regulation:	C5	Condensation
Comment:		The products can contribute to enabling a roof to satisfy the requirements of this Regulation. See section 5 of this Certificate.

Construction (Design and Management) Regulations 2007

Construction (Design and Management) Regulations (Northern Ireland) 2007

Information in this Certificate may assist the client, CDM co-ordinator, designer and contractors to address their obligations under these Regulations.

See sections: 1 *Description* (1.2) and 2 *Delivery and site handling* (2.3 and 2.4).

Non-regulatory Information

NHBC Standards 2008

NHBC accepts the use of Icopal Vapour Control Layers, when installed and used in accordance with this Certificate, in relation to *NHBC Standards*, Chapter 7.1, *Flat roofs and balconies*.

Zurich Building Guarantee Technical Manual 2007

In the opinion of the BBA, Icopal Vapour Control Layers, when installed and used in accordance with this Certificate, satisfy the requirements of the *Zurich Building Guarantee Technical Manual*, Section 4 *Superstructure*, Sub-section *Flat roofs*.

General

This Certificate relates to Icopal Vapour Control Layers, for use as high-resistance barriers with built-up felt roofing systems and other roof waterproofing or insulation systems covered by a current Agrément Certificate.

Technical Specification

1 Description

1.1 The Icopal Vapour Control Layers range consists of:

- Vapourflex — an SBS modified bitumen, polyester (135 gm⁻²) reinforced sheet with a 38 µm aluminium foil
- Vapourbar — an SBS modified bitumen, hessian (105 gm⁻²) reinforced sheet with a 38 µm aluminium foil.

1.2 The membranes are manufactured to the nominal characteristics given in Table 1.

Table 1 Nominal characteristics

Characteristic (unit)	Vapourflex	Vapourbar
Thickness (mm)	1.8	1.8
Roll width (m)	1.0	1.0
Roll length (m)	20	20
Roll weight (kg)	40	36
Mass per unit area (kgm ⁻²)	2.0	1.8

1.3 Other materials for use with the products include:

- Xtra-Seal SF Bitumen Primer, Xtra-Seal QD Bitumen Primer and Xtra-Seal Bitumen Primer — for use in preparation of masonry and roof substrates prior to the application of the waterproofing system
- Anderson HT 125 Taping Strip — a 150 mm wide strip of polyester reinforced bitumen membrane used to tape plywood or orientated strand board prior to the application of the waterproofing system.

1.4 Quality control checks are carried out on the raw materials, coating mass and the final product. Checks on the final product include:

- weight
- length
- bitumen/polymer content
- weight of washed-out base
- filler content.

2 Delivery and site handling

2.1 The membranes are delivered to site in rolls in printed wrappers bearing the product name, manufacturer's name and BBA identification mark incorporating the number of this Certificate.

2.2 Rolls should be stored upright on a clean, level surface, kept dry, away from excessive heat and kept under cover.

2.3 Xtra-Seal QD Bitumen Primer and Xtra-Seal Bitumen Primer have flash points of 25°C and 40°C respectively and must be stored away from ignition sources and extremes of temperature must also be avoided. These products are classified as 'flammable' and 'harmful' under *The Chemicals (Hazard Information and Packaging for Supply) Regulations 2002* (CHIP3) and should be handled accordingly.

2.4 Xtra-Seal SF Bitumen Primer is a solvent-free bitumen emulsion. The recommended storage temperature range is between 5°C and 35°C and must not be stored under 0°C.

Assessment and Technical Investigations

The following is a summary of the assessment and technical investigations carried out on Icopal Vapour Control Layers.

Design Considerations

3 General

3.1 Icopal Vapour Control Layers, are for use where a high resistance to water vapour is required, as defined in the relevant recommendations of BS 6229 : 2003, in conjunction with either of the following waterproofing or insulation specifications:

- built-up felt roofing to the relevant recommendations of BS 8217 : 2005, or
- other roof waterproofing or insulation systems covered by a current Agrément Certificate when laid in accordance with, and within the limitations imposed by, that Certificate.

3.2 Suitable decks must be designed in accordance with the relevant recommendations of BS 8217 : 2005, the relevant British Standards listed in BS 6229 : 2003, Clause 5.3 and, where appropriate, *NHBC Standards Chapter 7.1 Flat roofs and balconies* or the *Zurich Building Guarantee Technical Manual*, Section 4, *Superstructure*, Sub-section *Flat roofs* pages 268 to 270.

4 Practicability of installation

Installation of Icopal Vapour Control Layers must be carried out only by competent roofing contractors.

5 Resistance to water and water vapour



The products provide an effective control to the passage of liquid water and water vapour. See section 14 (Table for *Physical properties — general*).

6 Properties in relation to fire

The fire rating of a roof containing the vapour control layers will depend on the insulation and/or roof waterproofing and it is unlikely to be adversely affected by the presence of the vapour control layer.

7 Resistance to wind uplift

The adhesion of the bonded products is sufficient to resist the effects of wind suction, elevated temperature and thermal shock conditions likely to occur in practice. See section 14 (Table for *Physical properties — general*).

8 Resistance to foot traffic

The products can accept, without damage, the limited foot traffic associated with installation and maintenance operations. Reasonable care should be taken to avoid sharp objects or concentrated loads. See section 14 (Table for *Physical properties — general*).

9 Maintenance



As the products are part of a built-up roof specification and they have suitable durability (see section 10), maintenance is not required. However, it must be ensured that damage occurring before enclosure is repaired (see section 13).

10 Durability



Accelerated laboratory tests confirm that satisfactory retention of physical properties is achieved. The products will have a life at least as long as that of the roof waterproofing. See section 14.3.

Installation

11 General

11.1 Installation of Icopal Vapour Control Layers is carried out in accordance with the manufacturer's instructions and the relevant Clauses BS 8217 : 2005.

11.2 Deck surfaces must be dry, clean and free from sharp projections such as nail heads and concrete nibs.

11.3 The products may be laid in conditions normal to roofing work and must not be laid in rain, snow or heavy fog. The membranes remain flexible at temperatures down to at least 0°C.

12 Procedure

12.1 Where appropriate the substrate should be primed with one of the following primers, Xtra-Seal SF Bitumen Primer, Xtra-Seal QD Bitumen Primer or Xtra-Seal Bitumen Primer.

12.2 When applying the products to a softwood substrate, a first layer of Anderson HT 125 should be nailed in accordance with BS 8217 : 2005 using galvanized large headed clout nails. The vapour control layer is then fully bonded in hot bitumen as normal.

12.3 In all other cases, the products should be fully bonded with hot bitumen.

12.4 The vapour control layers can be cut to the required size with a sharp knife.

13 Repair

In the event of damage, the sheets can be effectively repaired, prior to the installation of the upper layers of the system, using traditional methods for bonding bituminous felts.

14 Tests

14.1 Samples of the Icopal Vapour Control Layers were obtained from the Certificate holder for testing. The results of the tests carried out by the BBA are summarised in Tables 2 and 3.

Table 2 Physical properties — directional

Tests (units)	Mean results		Method ⁽¹⁾
	Longitudinal	Transverse	
Tensile strength (N per 50 mm)			BS 2782-3.320A (100 mm min ⁻¹)
Vapourflex	634	656	
Vapourbar	581	205	
Elongation at break (%)			BS 2782-3.320A (100 mm min ⁻¹)
Vapourflex	37	29	
Vapourbar	9	6	
Dimensional stability (free) (%)			MOAT 27 : 5.1.6.1
Vapourflex	-0.20	+0.02	
Vapourbar	-0.03	-0.01	

(1) The test documents are detailed in the *Bibliography*. Numbers in the table refer to sections/parts of the various documents.

Table 3 Physical properties — general

Tests (units)	Mean results		Method ⁽¹⁾
	Vapourflex	Vapourbar	
Water vapour transmission (gm ⁻² day ⁻¹)	0.16	0.04	BS 3177 (25°C/75% RH)
Water vapour resistance (MNsg ⁻¹)	1324	4663	BS 3177 (25°C/75% RH)
Static indentation			MOAT 27 : 5.1.9
substrate			
concrete	–	L ₂	
EPS	–	L ₁	
Dynamic indentation			MOAT 27 : 5.1.10
substrate			
perlite	–	L ₂	
EPS	–	L ₁	
Peel strength (N per 50 mm)			MOAT 31 : 6I
concrete	43	–	
timber	52	–	

(1) The test documents are detailed in the *Bibliography*. Numbers in the table refer to sections/parts of the various documents.

– Not tested.

14.2 When unrolling Vapourflex and Vapourbar at low temperature, in accordance with MOAT No 27 : 1983, test 5.4.3, the membranes performed satisfactorily.

14.3 When low temperature flexibility test on unaged samples of Vapourflex and Vapourbar and heat aged (28 days at 70°C) samples of Vapourbar in accordance with MOAT No 27 : 1983, test 5.4.2, the membranes performed satisfactorily.

15 Investigations

15.1 The manufacturing process was examined, including the methods adopted for quality control, and details were obtained of the quality and composition of the materials used.

15.2 A visit was made to a site in progress to assess the practicability of installation.

Bibliography

BS 2782-3.320A to 320F : 1976 *Methods of testing plastics — Mechanical properties — Tensile strength, elongation and elastic modulus*

BS 3177 : 1959 *Method for determining the permeability to water vapour of flexible sheet materials used for packaging*

BS 6229 : 2003 *Flat roofs with continuously supported coverings — Code of practice*

BS 8217 : 2005 *Reinforced bitumen membranes for roofing — Code of practice*

MOAT No 27 : 1983 *General Directive for the Assessment of Roof Waterproofing Systems*

MOAT No 31 : 1984 *Special Directives for the Assessment of Reinforced Homogeneous Waterproof Coverings of Styrene-Butadiene-Styrene (SBS) Elastomer Bitumen*

16 Conditions

16.1 This Certificate:

- relates only to the product/system that is named and described on the front page
- is granted only to the company, firm or person named on the front page — no other company, firm or person may hold or claim any entitlement to this Certificate
- is valid only within the UK
- has to be read, considered and used as a whole document — it may be misleading and will be incomplete to be selective
- is copyright of the BBA
- is subject to English law.

16.2 References in this Certificate to any Act of Parliament, Statutory Instrument, Directive or Regulation of the European Union, British, European or International Standard, Code of Practice, manufacturers' instructions or similar publication, are references to such publication in the form in which it was current at the date of this Certificate.

16.3 This Certificate will remain valid for an unlimited period provided that the product/system and the manufacture and/or fabrication including all related and relevant processes thereof:

- are maintained at or above the levels which have been assessed and found to be satisfactory by the BBA
- continue to be checked as and when deemed appropriate by the BBA under arrangements that it will determine
- are reviewed by the BBA as and when it considers appropriate.

16.4 In granting this Certificate, the BBA is not responsible for:

- the presence or absence of any patent, intellectual property or similar rights subsisting in the product/system or any other product/system
- the right of the Certificate holder to manufacture, supply, install, maintain or market the product/system
- individual installations of the product/system, including the nature, design, methods and workmanship of or related to the installation
- the actual works in which the product/system is installed, used and maintained, including the nature, design, methods and workmanship of such works.

16.5 Any information relating to the manufacture, supply, installation, use and maintenance of this product/system which is contained or referred to in this Certificate is the minimum required to be met when the product/system is manufactured, supplied, installed, used and maintained. It does not purport in any way to restate the requirements of the Health & Safety at Work etc Act 1974, or of any other statutory, common law or other duty which may exist at the date of this Certificate; nor is conformity with such information to be taken as satisfying the requirements of the 1974 Act or of any statutory, common law or other duty of care. In granting this Certificate, the BBA does not accept responsibility to any person or body for any loss or damage, including personal injury, arising as a direct or indirect result of the manufacture, supply, installation, use and maintenance of this product/system.

