

## IKO PLC

Appley Lane North  
Appley Bridge  
Wigan  
Lancashire WN6 9AB

Tel: 0844 412 7228 Fax: 0844 412 7229  
e-mail: technical@ikogroup.co.uk  
website: www.ikogroup.co.uk



Agrément Certificate  
**95/3133**  
Product Sheet 4

## IKO DAMP-PROOF COURSES

### DAMPROTEC SYSTEM

#### PRODUCT SCOPE AND SUMMARY OF CERTIFICATE

This Certificate relates to the Damprotec System, for use in providing horizontal, vertical, or stepped dpc's including cavity trays, in either solid or cavity walls of brick, block, stone or concrete.

#### AGRÉMENT CERTIFICATION INCLUDES:

- factors relating to compliance with Building Regulations where applicable
- factors relating to additional non-regulatory information where applicable
- independently verified technical specification
- assessment criteria and technical investigations
- design considerations
- installation guidance
- regular surveillance of production
- formal three-yearly review.



#### KEY FACTORS ASSESSED

**Behaviour under load** — the system will not extrude under load, up to the point of compressive failure of the wall (see section 5).

**Resistance to water and water vapour** — the system will provide an effective barrier against liquid water and water vapour (see section 6).

**Compatibility with other materials** — when used in normal construction, the system is compatible with all materials with which it will be in contact with, except for timber preservatives based on creosote or tar oils (see section 7).

**Durability** — when properly specified and installed, the system in normal circumstances, will remain effective during the lifetime of the building (see section 9).

The BBA has awarded this Agrément Certificate to the company named above for the system described herein. The system has been assessed by the BBA as being fit for its intended use provided it is installed, used and maintained as set out in this Certificate

On behalf of the British Board of Agrément

Simon Wroe  
Head of Approvals — Materials

Greg Cooper  
Chief Executive

Date of First issue: 13 July 2009

*The BBA is a UKAS accredited certification body — Number 113. The schedule of the current scope of accreditation for product certification is available in pdf format via the UKAS link on the BBA website at [www.bbacerts.co.uk](http://www.bbacerts.co.uk)*

*Readers are advised to check the validity and latest issue number of this Agrément Certificate by either referring to the BBA website or contacting the BBA direct.*

British Board of Agrément  
Bucknalls Lane  
Garston, Watford  
Herts WD25 9BA

©2009

tel: 01923 665300  
fax: 01923 665301  
e-mail: mail@bba.star.co.uk  
website: [www.bbacerts.co.uk](http://www.bbacerts.co.uk)

# Regulations

In the opinion of the BBA, the Damprotec System if used in accordance with the provisions of this Certificate, will meet or contribute to meeting the relevant requirements of the following Building Regulations:



## The Building Regulations 2000 (as amended) (England and Wales)

Requirement:	A1	Loading
Comment:	The system will not extrude under load, up to the point of failure of the wall, and will not adversely affect the ability of a properly designed and built wall to sustain and transmit compression loads. The presence of a dpc can reduce the shear and tensile strength of a wall at that point, and design may need to take account of this. See section 5.1 of this Certificate.	
Requirement:	C2(a)(b)	Resistance to moisture
Comment:	Properly installed in a correctly designed structure, the system forms an effective barrier to the movement of water within the wall, enabling compliance with this Requirement. See section 6 of this Certificate.	
Requirement:	Regulation 7	Materials and workmanship
Comment:	The system is acceptable. See section 9 and the <i>Installation</i> part of this Certificate.	



## The Building (Scotland) Regulations 2004 (as amended)

Regulation:	8(1)(2)	Fitness and durability of materials and workmanship
Comment:	The system can contribute to a construction satisfying this Regulation. See sections 8 and 9 and the <i>Installation</i> part of this Certificate.	
Regulation:	9	Building standards – construction
Standard:	1.1(a)(b)	Structure
Comment:	The system will not extrude up to the point of failure of the wall, and will not adversely affect the ability of the properly designed and build wall to sustain and transmit compression loads, with reference to clauses 1.1.1 <sup>(1)(2)</sup> and 1.1.3 <sup>(1)(2)</sup> . See section 5.1 of this Certificate.	
Standard:	3.4	Moisture from the ground
Standard:	3.10	Precipitation
Comment:	Properly installed in a correctly designed structure, the system forms an effective barrier to the movement of water within the wall, enabling compliance with these Standards, with reference to clauses 3.4.1 <sup>(1)(2)</sup> and 3.10.1 <sup>(1)(2)</sup> . See section 6 of this Certificate.	
Regulation:	12	Building standards – conversions
Comment:	All comments given for the system under Regulation 9, also apply to this Regulation, with reference to clause 0.12.1 <sup>(1)(2)</sup> and Schedule 6 <sup>(1)(2)</sup> . (1) Technical Handbook (Domestic). (2) Technical Handbook (Non-Domestic).	



## The Building Regulations (Northern Ireland) 2000 (as amended)

Regulation:	B2	Fitness of materials and workmanship
Comment:	The system is acceptable. See section 9 and the <i>Installation</i> part of this Certificate.	
Regulation:	B3(2)	Suitability of certain materials
Comment:	The system does not normally require maintenance. See section 8 of this Certificate.	
Regulation:	C4	Resistance to ground moisture and weather
Comment:	Properly installed in a correctly designed structure, the system forms an effective barrier to the movement of water within the wall, enabling compliance with this Regulation. See section 6 of this Certificate.	
Regulation:	D1	Stability
Comment:	The system will not extrude, up to the point of failure of the wall, and will not adversely affect the ability of a properly designed and built wall to sustain and transmit compression loads. See section 5.1 of this Certificate.	

## Construction (Design and Management) Regulations 2007

## Construction (Design and Management) Regulations (Northern Ireland) 2007

Information in this Certificate may assist the client, CDM co-ordinator, designer and contractors to address their obligation under these Regulations.

See sections: 1 *Description* (1.2) and 2 *Delivery and site handling* (2.5).

# Non-regulatory Information

## NHBC Standards 2008

NHBC accepts the use of the Damprotec System, when installed and used in accordance with this Certificate, in relation to *NHBC Standards*, Chapter 6.1 *External masonry walls*.

## Zurich Building Guarantee Technical Manual 2007

In the opinion of the BBA, the Damprotect System, when installed and used in accordance with this Certificate, satisfies the requirements of the *Zurich Building Guarantee Technical Manual, Section 3 Substructure, Sub-section dpc and dpm* (page 107).

### Technical Specification

#### 1 Description

1.1 Damprotect damp-proof course is a flexible black sheet material with grained surfaces. It consists a mixture of pitch, PVC, synthetic fibres and other additives.

1.2 The sheet is manufactured to dimensions of:

nominal thickness (mm)	1.10
nominal weight (kgm <sup>-2</sup> )	1.425
roll length (m)	20
roll widths (mm)	100, 112.5, 150, 225, 300, 337.5, 360, 450, 600, 900

1.3 Hyload preformed cavity tray units are made from 1.5 mm thick polymer sheet and are preformed, flexible units for angles in stepped or horizontal damp-proof coursing. Typical examples are shown in Figure 1. Cloaks to other designs can be fabricated to order.

Figure 1 Standard Hyload preformed cavity tray units (special sizes and shapes to order)

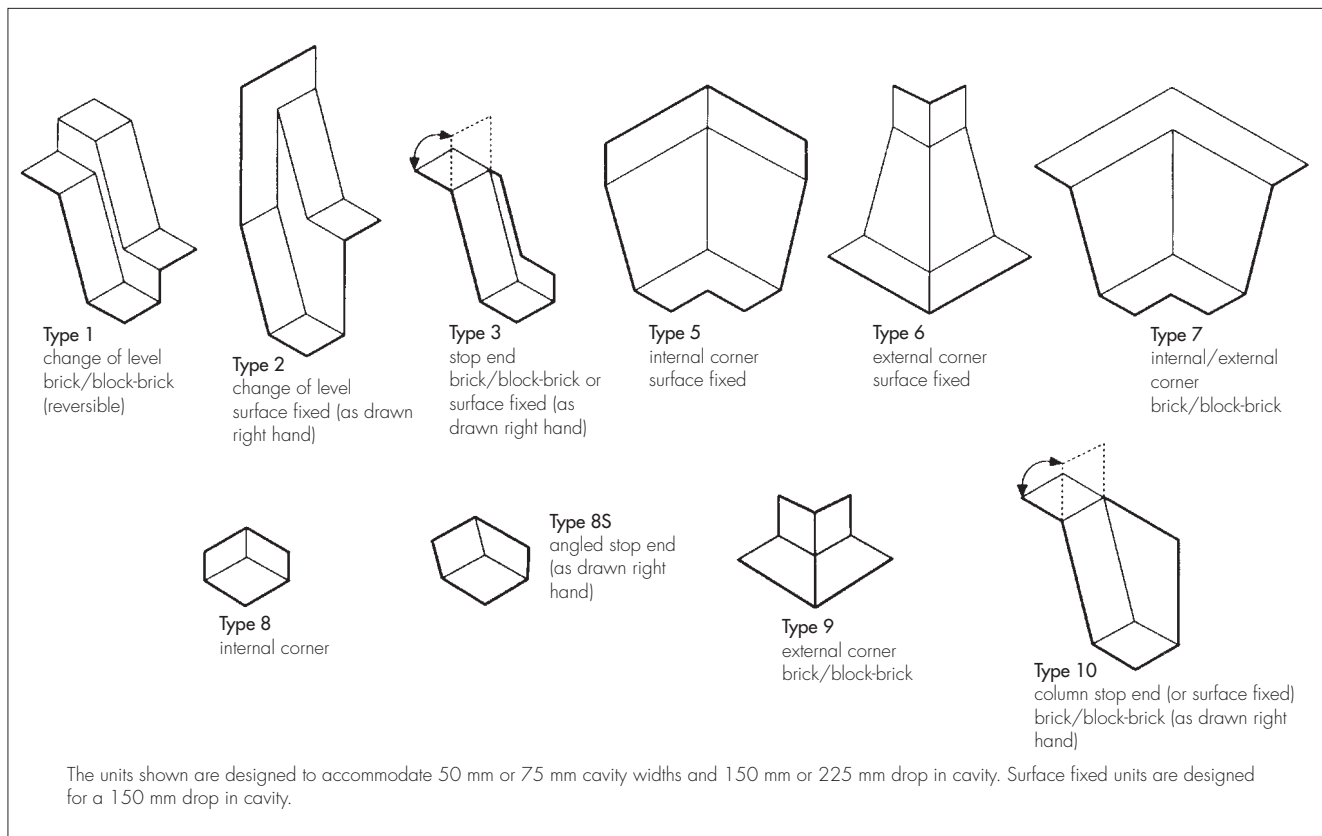

1.4 Hyload DPC Joint Support System consists of 350 mm by 200 mm reinforced supports of twin-walled polypropylene with a 120 mm self-adhesive strip protected by silicone release paper bonded to its upper surface. Joints are formed by means of a 100 mm wide self-adhesive tape protected on both sides by silicone release paper.

1.5 IKOpro SA Primer is used where required on concrete, brickwork, blockwork and steel.

1.6 Hyload DPC Lap Adhesive is a medium-viscosity synthetic rubber/resin adhesive of instant contact type. See section 11.1.

1.7 Hyload DPC Mastic is a thick synthetic rubber mastic with gap filling properties and is suitable for bonding Hyload to Hyload and to a range of common building materials. See section 13.1.

1.8 Hyload DPC fixing strip is a semi-rigid plastic strip, 25 mm by 3 mm by 2 m, pre-drilled at 150 mm centres.

1.9 Hyload DPC fixing pins are for use with Hyload DPC fixing strip for fixing to solid internal substrates such as blockwork, stone and concrete.

1.10 Quality control on the product includes checks on dimensions and by sampling, on low temperature flexibility, tensile strength, elongation, tear resistance and high-temperature stability.

## 2 Delivery and site handling

- 2.1 The dpc is delivered to site in rolls secured with a paper wrapper bearing the manufacturer's name and the BBA identification mark incorporating the number of this Certificate. The product name is stamped across the sheet at intervals along the length of the roll.
- 2.2 Rolls must be stored on end and under cover. Contact with organic solvents must be avoided.
- 2.3 Hyload preformed cavity tray units are delivered to site in cardboard boxes. A label bearing a description of the contents and the BBA identification mark incorporating the number of this Certificate is affixed to each box.
- 2.4 Hyload DPC Joint Support System is supplied in cardboard cartons, each containing 15 support units, a 10 m roll of self-adhesive tape and full fixing instructions.
- 2.5 IKOpro SA Primer is classified as 'flammable' and 'harmful' under *The Chemicals (Hazard Information and Packaging for Supply) Regulations 2002 (CHIP3)* and should be stored appropriately. The dpc container bears the appropriate hazard warning.

## Assessment and Technical Investigations

The following is a summary of the assessment and technical investigations carried out on the Damprotec System.

## Design Considerations

### 3 Use

- 3.1 The Damprotec System, when correctly specified and installed in accordance with this Certificate, provide satisfactory horizontal, vertical, or stepped damp-proof coursing (including cavity trays) in either solid or cavity walls of brick, block, stone or concrete. General standards of good design practice are given in BS 5628-3 : 2005.
- 3.2 Cavity trays, steps, angles and stop ends are preformed in the factory (see Figure 1).
- 3.3 The Hyload DPC Joint Support System provides an effective method of joining the dpc to itself or to Hyload cavity tray units.
- 3.4 The components may be used separately or with each other.

### 4 Practicability of installation

The system is designed to be installed by a bricklayer, experienced with this type of system.

### 5 Behaviour under load

-  5.1 The system will not extrude under load, up to the point of compressive failure of the wall, and will not adversely affect the ability of a properly designed and built wall to sustain and transmit compression. The presence of the dpc can, however, reduce the shear and tensile (and therefore, bending) strengths of a wall at that point, and designs may need to take account of this. Allowable stresses on the dpc are detailed in the product literature and further guidelines are available from the Certificate holder.
- 5.2 The system will withstand considerable movement of the wall, and is unlikely to be impaired by normally occurring movements up to the point where the wall itself is deemed to have failed.

### 6 Resistance to water and water vapour

-  When correctly specified and installed the system will provide an effective barrier against liquid water and water vapour either from a source external to the structure, or from one part of the structure to another.

### 7 Compatibility with other materials

The system is compatible with all materials with which it will be in contact within normal construction, with the exception of timber preservatives based on creosote or tar oils. It is unaffected by timber preservatives which are water-based solutions of salts. Where there is doubt about the compatibility with materials in contact, the advice of the Certificate holder's Technical Department should be sought.

### 8 Maintenance

-  As the system is confined within the wall and wall cavity and has suitable durability (see section 9), maintenance is not required. However, it must be ensured that damage occurring before enclosure is repaired (see section 15).

## 9 Durability



Results of artificial ageing tests and assessment of constituent materials indicate that a satisfactory performance in use and retention of physical properties are achieved. When properly specified and installed, the system will in normal circumstances remain effective for the lifetime of the building.

## Installation

### 10 General

10.1 Installation of the Damprotec System must follow normal good practice for the detailing of damp-proof courses, as set out in BS 5628-3 : 2005, and must be in accordance with the relevant clauses of BS 8000-3 : 2001, BS 8215 : 1991, BRE Digest 380 *Damp-proof courses*, and the manufacturer's instructions.

10.2 As with all flexible dpc's care should be taken to avoid impact damage from sharp objects (eg chisel) during installation.

### 11 Handling

11.1 The dpc is handled and cut as conventional flexible damp-proof courses. It retains sufficient flexibility to be used at the lowest temperature at which walls are normally built and does not become tacky in warm, ambient weather conditions.

11.2 It is difficult to form certain details with the dpc, particularly when bending the material through two angles at the same time. In such cases, care must be taken to achieve a satisfactory seal, and where necessary preformed cloaks should be used. Joints should be formed on site by means of the Hyload DPC Lap adhesive, Hyload DPC Mastic or the Hyload DPC Joint Support System. Care should be taken at temperatures below 5°C to avoid the risk of condensation on jointed surfaces which may affect the efficiency of the self-adhesive tape.

### 12 Installation practice

12.1 The following installation practices are essential:

- the dpc must extend through the full thickness of the wall or wall-leaf, including pointing, applied rendering or other facing material
- the dpc must be laid on a wet, even bed of mortar, and perforations in adjacent courses of brickwork must be closed with mortar, and project 5 mm beyond the finished face
- the dpc must always be sandwiched between wet mortar and not laid dry
- all lap joints in the dpc must have 100 mm overlap and be completely sealed (see appropriate clauses of section 13)
- Hyload Preformed Cavity Tray Units must be used at stop ends, and at all corners or changes in levels of cavity trays
- where used as a cavity tray, the dpc laps must be sealed.

12.2 When using the dpc with boot lintels or similar constructions, it is recommended that the material is installed to follow the lintel profile, where appropriate.

### 13 Jointing procedures

13.1 Lap joints must be bonded using one of the following methods:

- Hyload DPC Lap Adhesive is applied to each surface to be bonded, and when dry the two surfaces should be pressed firmly together
- Hyload DPC Mastic is spread on one surface, brought into contact with the second surface and pressed firmly by hand. If a shearing force is expected within 72 hours of bonding, then support against slippage should be provided.

#### Hyload DPC Joint Support System

13.2 All surfaces to be jointed should be clean and dry. Release paper protecting the self-adhesive strips should not be removed until the joint is ready to be formed. The support unit and tape should not be left exposed overnight or during periods of low temperatures.

13.3 When forming a lap joint using the support unit and self-adhesive tape the manufacturer's instructions should be followed.

13.4 The support unit should be fitted in such a way as to span the cavity, the ends of the support unit being bent so as to bear upon the inner and outer leaves of the wall for a distance of between 25 and 40 mm. If necessary, the support unit may be temporarily fixed in place [see Figure 2, (1) and (2)].

Figure 2 Application of the Damprotec System

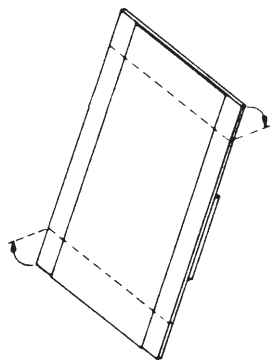

1 system joint support, bend ends to bear on inner and outer leaves by 25–40 mm

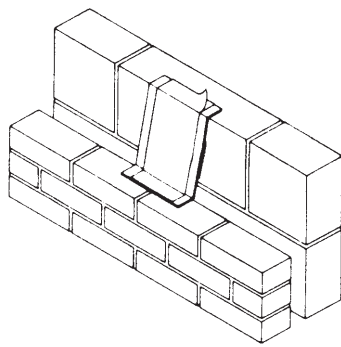

2 joint support prior to dpc application, only remove silicone release paper immediately prior to making joint

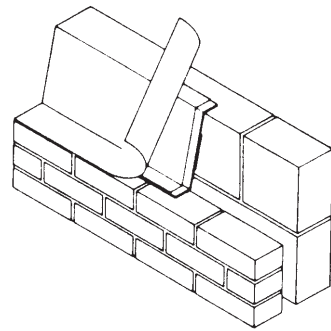

3 apply uniform pressure when positioning dpc on joint support

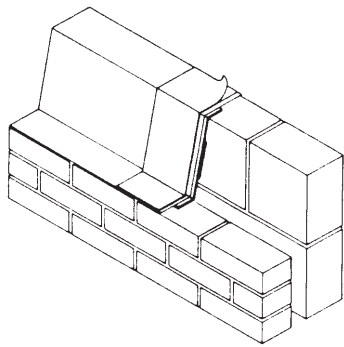

4 Hyload DPC Jointing Tape bonded to dpc

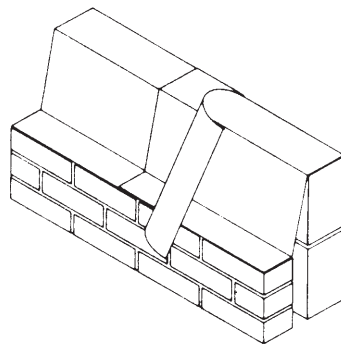

5 remove top silicone release paper and immediately lap and bond dpc

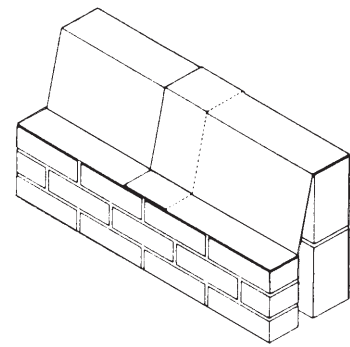

6 supported and watertight 100 mm wide joint

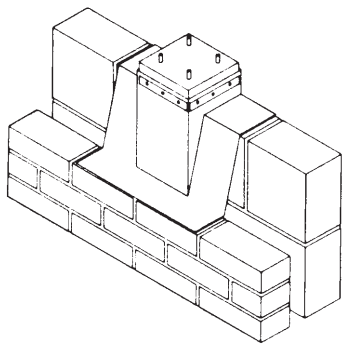

7 Preformed Hyload cavity tray unit bonded to primed face of concrete column using Hyload DPC Jointing Tape and mechanically fixed using Hyload DPC Fixing Strip

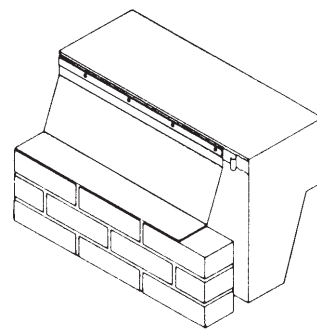

8 Damprotec bonded to primed face of edge beam using Hyload DPC Jointing Tape and mechanically fixed using Hyload DPC Fixing Strip

- All surfaces to be joined must be clean and dry.
- Only remove silicone release paper from adhesive at time of making joint.
- The support system must rest on each brick/block by between 25 mm and 40 mm.
- Apply uniform pressure when making joint.
- For ease of use, avoid exposure to low temperatures.
- If applying tape to brick/block or concrete, surfaces must be primed using IKOpro SA Primer.

13.5 The first layer of dpc or the cavity tray unit to be joined should be offered up to the support unit. The release paper should be removed from the adhesive strip and, by application of uniform pressure, the dpc or cavity tray unit bonded to it [see Figure 2, (3)].

13.6 A strip of self-adhesive tape should then be applied to the upper surface of the dpc or cavity tray unit over the area supported by the support unit [see Figure 2, (4)].

13.7 The layer of dpc to be lapped to the first should be placed in the usual way, the upper silicone release paper removed and the joint formed, ensuring that a full seal is achieved [see Figure 2, (5) and (6)].

13.8 Where the dpc or cavity tray unit is required to be bonded to a brick, block or concrete substrate it can be held, temporarily, in place by means of the self-adhesive tape bonded to the substrate, which must be primed with IKOpro SA Primer. A permanent mechanical fixing should then be installed using Hyload DPC Fixing Strip [see Figure 2, (7) and (8)].

## 14 Cleaning cavities

As with most other damp-proof course materials, damage can occur during cleaning of mortar droppings from the damp-proof course unless care is taken. The following recommendations should prevent damage occurring:

- cavity battens should be used to prevent excessive amounts of mortar droppings reaching the damp-proof course
- mortar droppings should be removed before they have had time to harden
- implements such as steel rods should never be used for cleaning
- damp-proof courses should be examined for damage as work proceeds.

## 15 Repair

Damaged dpc and cavity tray units should be replaced prior to the installation of brick, block or masonry courses above the dpc/cavity tray unit.

# Technical Investigations

## 16 Tests

16.1 The Damprotec System was assessed on the basis of the following tests carried out on products of a similar specification:

- thickness
- tensile strength and elongation at break
- flexibility at low temperatures
- resistance to water transmission under pressure
- water absorption
- resistance to compression at high temperatures
- weight per unit area
- handling characteristics
- water vapour permeability
- effect of ageing at high temperatures
- dimensional stability
- resistance to puncturing and point loading splitting under simulated service conditions.

16.2 The following tests were carried out on the preformed cavity tray units:

- tensile strength/elongation of sheet and welds
- tear strength of sheet and welds
- joint strength
- low temperature flexibility of sheet and welds.

## 17 Investigations

17.1 The manufacturing process was examined, including the method adopted for quality control, and details were obtained of the quality and composition of the materials used.

17.2 An examination was made of reports of shear and flexure tests carried out on products of similar specification to DD 86-1 : 1983. The results were found to be satisfactory.

# Bibliography

BS 5628-3 : 2005 *Code of practice for the use of masonry — Materials and components, design and workmanship*

BS 8000-3 : 2001 *Workmanship on building sites — Code of practice for masonry*

BS 8215 : 1991 *Code of practice for design and installation of damp-proof courses in masonry construction*

DD 86-1 : 1983 *Damp-proof courses — Methods of test for flexural bond strength and short term shear strength*

## 18 Conditions

18.1 This Certificate:

- relates only to the product/system that is named and described on the front page
- is granted only to the company, firm or person named on the front page — no other company, firm or person may hold or claim any entitlement to this Certificate
- is valid only within the UK
- has to be read, considered and used as a whole document — it may be misleading and will be incomplete to be selective
- is copyright of the BBA
- is subject to English law.

18.2 Publications and documents referred to in this Certificate are those that the BBA deems to be relevant at the date of issue or re-issue of this Certificate and include any: Act of Parliament; Statutory Instrument; Directive; Regulation; British, European or International Standard; Code of Practice; manufacturers' instructions; or any other publication or document similar or related to the aforementioned.

18.3 This Certificate will remain valid for an unlimited period provided that the product/system and the manufacture and/or fabrication including all related and relevant processes thereof:

- are maintained at or above the levels which have been assessed and found to be satisfactory by the BBA
- continue to be checked as and when deemed appropriate by the BBA under arrangements that it will determine
- are reviewed by the BBA as and when it considers appropriate.

18.4 In granting this Certificate, the BBA is not responsible for:

- the presence or absence of any patent, intellectual property or similar rights subsisting in the product/system or any other product/system
- the right of the Certificate holder to manufacture, supply, install, maintain or market the product/system
- individual installations of the product/system, including the nature, design, methods and workmanship of or related to the installation
- the actual works in which the product/system is installed, used and maintained, including the nature, design, methods and workmanship of such works.

18.5 Any information relating to the manufacture, supply, installation, use and maintenance of this product/system which is contained or referred to in this Certificate is the minimum required to be met when the product/system is manufactured, supplied, installed, used and maintained. It does not purport in any way to restate the requirements of the Health & Safety at Work etc Act 1974, or of any other statutory, common law or other duty which may exist at the date of this Certificate; nor is conformity with such information to be taken as satisfying the requirements of the 1974 Act or of any statutory, common law or other duty of care. In granting this Certificate, the BBA does not accept responsibility to any person or body for any loss or damage, including personal injury, arising as a direct or indirect result of the manufacture, supply, installation, use and maintenance of this product/system.