



Passivent Ltd

2 Brooklands Road
Sale
Cheshire M33 3SS

Tel: 0161-962 7113 Fax: 0161-905 2085
e-mail: info@passivent.com
website: www.passivent.com

**Agrément
Certificate
No 96/3273**

*Third issue**

Designated by Government
to issue
European Technical
Approvals

PASSIVENT SYSTEMS

Système de ventilation
Ventilationssystem

Product



• *THIS CERTIFICATE RELATES TO PASSIVENT VENTILATION SYSTEMS.*

- *The systems provide extract ventilation for occupants of new or existing dwellings or buildings of similar occupancy and condition.*
- *It is essential that the systems are installed and used in accordance with the Certificate holder's instructions and the provisions of this Certificate.*

These Front Sheets must be read in conjunction with the accompanying Detail Sheets, which provide information to specific systems.

Regulations – Detail Sheet 1

1 The Building Regulations 2000 (as amended) (England and Wales)

 The Secretary of State has agreed with the British Board of Agrément the aspects of performance to be used by the BBA in assessing the compliance of ventilation systems with the Building Regulations. In the opinion of the BBA, Passivent Systems, if used in accordance with the provisions of this Certificate, will meet or contribute to meeting the relevant requirements.

Requirement: **B2(1)**

Comment:

Internal fire spread (linings)

Wall- and ceiling-mounted components need not be considered as subject to this Requirement. See the relevant tinted areas of the *Behaviour in relation to fire* section of the accompanying Detail Sheets.

Requirement: **B3**

Comment:

Internal fire spread (structure)

The systems will meet this requirement where non-combustible ducting in combination with fire damper and suitable sleeving penetrates a compartment or separating floor. See the relevant tinted areas of the *Behaviour in relation to fire* section of the accompanying Detail Sheets.

Requirement: **B4(1)**

Comment:

External fire spread

Wall-mounted components constitute unprotected areas and may be used within otherwise protected areas. See the relevant tinted areas of the *Behaviour in relation to fire* section of the accompanying Detail Sheets.

Requirement:	B4(2)	External fire spread
Comment:		Roof-mounted components will not affect the rating of a roof. See the relevant tinted areas of the <i>Behaviour in relation to fire</i> section of the accompanying Detail Sheets.
Requirement:	C2(b)(c)	Resistance to moisture
Comment:		Externally mounted components will not affect the ability of a roof or wall to meet this Requirement. See the <i>Weathertightness</i> section of these Front Sheets and the relevant tinted areas of the <i>Condensation</i> section of the accompanying Detail Sheets.
Requirement:	F1	Means of ventilation
Comment:		The systems can meet this Requirement. See the relevant tinted areas of the <i>Ventilation</i> section of the accompanying Detail Sheets.
Requirement:	Regulation 7	Materials and workmanship
Comment:		The components are acceptable. See the tinted area of the <i>Durability</i> section of the accompanying Detail Sheets.

2 The Building (Scotland) Regulations 2004 (as amended)



In the opinion of the BBA, Passivent Systems, if used in accordance with the provisions of this Certificate, will satisfy or contribute to satisfying the various Regulations and related Mandatory Standards as listed below.

Regulation:	8	Fitness and durability of materials and workmanship
Regulation:	8(1)	Fitness and durability of materials and workmanship
Comment:		The systems can contribute to a construction meeting this Standard. See the tinted area of the <i>Durability</i> section and the <i>Installation</i> part of the accompanying Detail Sheets.
Regulation:	9	Building standards — construction
Standard:	2.2	Separation
Comment:		The systems will satisfy this Standard where non-combustible ducting in combination with fire damper and suitable sleeving penetrates a compartment or separating floor, with reference to clauses, 2.1.1 ⁽¹⁾ , 2.2.2 ⁽¹⁾ , 2.2.3 ⁽¹⁾ and 2.2.9 ⁽¹⁾ . See the relevant tinted areas of the <i>Behaviour in relation to fire</i> section of the accompanying Detail Sheets.
Standard:	2.4	Cavities
Comment:		Components mounted on internal wall and ceiling surfaces are of limited area and will not significantly affect fire spread with reference to clauses 2.4.3 ⁽¹⁾ , 2.4.4 ⁽¹⁾ , 2.4.6 ⁽¹⁾ of this Standard. See the relevant tinted areas of the <i>Behaviour in relation to fire</i> section of the accompanying Detail Sheets.
Standard:	2.5	Internal linings
Comment:		Roof-mounted components will not affect the rating of a roof, with reference to clauses 2.5.3 ⁽¹⁾ , 2.5.5 ⁽¹⁾ and 2.5.6 ⁽¹⁾ of this Standard. See the relevant tinted areas of the <i>Behaviour in relation to fire</i> section of the accompanying Detail Sheets.
Standard:	3.10	Precipitation
Comment:		Externally-mounted components will not affect the ability of the roof or wall to satisfy this Standard, with reference to clauses 3.10.1 ⁽¹⁾ , 3.10.2 ⁽¹⁾ , 3.10.3 ⁽¹⁾ , 3.10.5 ⁽¹⁾ , 3.10.6 ⁽¹⁾ and 3.10.7 ⁽¹⁾ . See the <i>Weathertightness</i> section of these Front Sheets.
Standard:	3.14	Ventilation
Comment:		The systems can satisfy this Standard, with reference to clauses 3.14.4 ⁽¹⁾ , 3.14.6 ⁽¹⁾ , and 3.14.8 ⁽¹⁾ . See the relevant tinted areas of the <i>Ventilation</i> section of the accompanying Detail Sheets.
Standard:	3.15	Condensation
Comment:		The systems will contribute to minimising the risk of surface condensation. See the relevant tinted areas of the <i>Condensation</i> section of the accompanying Detail Sheets.

(1) Technical Handbook (Domestic).

3 The Building Regulations (Northern Ireland) 2000 (as amended)



In the opinion of the BBA, Passivent Systems, if used in accordance with the provisions of this Certificate, will satisfy or contribute to satisfying the various Building Regulations as listed below.

Regulation:	B2	Fitness of materials and workmanship
Comment:		The systems are acceptable. See the tinted area of the <i>Durability</i> section of the accompanying Detail Sheets.
Regulation:	C4	Resistance to ground moisture and weather
Comment:		Externally mounted components will not affect the ability of the roof or wall to satisfy this Regulation. See the <i>Weathertightness</i> section of these Front Sheets.

Regulation:	C5	Condensation
Comment:		The systems will contribute to minimising the risk of surface condensation. See the relevant tinted areas of the <i>Condensation</i> section of the accompanying Detail Sheets.
Regulation:	E2	Means of escape
Comment:		Components mounted on internal wall or ceiling surface will not significantly affect a linings resistance to fire spread. See the relevant tinted areas of the <i>Behaviour in relation to fire</i> section of the accompanying Detail Sheets.
Regulation:	E3	Internal fire spread — Linings
Comment:		The systems as described in Detail Sheet 3 will satisfy this Regulation where non-combustible ducting in combination with fire damper and suitable sleeving penetrates a compartment or separating floor. See the relevant tinted areas of the <i>Behaviour in relation to fire</i> section of the accompanying Detail Sheets.
Regulation:	E4	Internal fire spread — Structure
Comment:		When used in an otherwise protected area, wall-mounted components may be disregarded provided the minimum distances from other unprotected areas are maintained. Roof-mounted components will not affect the rating of a roof. See the relevant tinted areas of the <i>Behaviour in relation to fire</i> section of the accompanying Detail Sheets.
Regulation:	K2	Means of ventilation
Comment:		The systems can satisfy this Regulation. The air inlets and outlets must be appropriately situated, for example by satisfying the relevant provisions of section 2 of the approved Document K. See the relevant tinted areas of the <i>Ventilation</i> section of the accompanying Detail Sheets.

4 Construction (Design and Management) Regulations 2007 Construction (Design and Management) Regulations (Northern Ireland) 1995 (as amended)

Information in this Certificate may assist the client, CDM co-ordinator or planning supervisor, designer and contractors to address their obligations under these Regulations.

See sections: *6 Delivery to site and storage (6.2)*, and *7 Combustion appliances* of these Front Sheets.

5 The Electrical Equipment (Safety) Regulations 1994 and the Electromagnetic Compatibility Regulations 2005

These Regulations implement the Low Voltage Directive 73/23/EEC (as amended by the CE Marking Directive 93/68/EEC) and the Electromagnetic Compatibility Directive 89/3336/EEC and require manufacturers to carry out assessment of their products against the criteria given in the Directives. Declarations of Conformity have been provided by Passivent Ltd. The BBA has not assessed the product for compliance with these Directives.

Technical Specification

6 Delivery to site and storage

6.1 Apart from ducting and its associated items, Passivent Systems components are individually boxed.

6.2 The products should be stored in clean, dry surroundings and protected from mechanical damage until ready for use.

7 Combustion appliances

When ventilating a room containing a combustion appliance care should be taken to ensure sufficient permanent openings in the room, under all circumstances, to permit the safe and efficient operation of the appliance. Guidance in this respect may be found in the following documents:

England and Wales

Approved Documents J and F1

Scotland

Mandatory Standards 3.17 and 3.21,

Northern Ireland

Technical Booklet L.

8 Weathertightness



The use of the ventilators will not affect the ability of a wall or roof to comply with:

England and Wales

Requirement C2

Scotland

Mandatory Standard 3.10, clauses 3.10.1⁽¹⁾, 3.10.2⁽¹⁾, 3.10.3⁽¹⁾, 3.10.5⁽¹⁾, 3.10.6⁽¹⁾, 3.10.7⁽¹⁾

Northern Ireland

Regulation C4.

(1) Technical Handbook (Domestic).

Conditions of Certification

9 Conditions

9.1 This Certificate:

- relates only to the product/system that is named and described on the front page
- is granted only to the company, firm or person named on the front page — no other company, firm or person may hold or claim any entitlement to this Certificate
- is valid only within the UK
- has to be read, considered and used as a whole document — it may be misleading and will be incomplete to be selective
- is copyright of the BBA
- is subject to English law.

9.2 References in this Certificate to any Act of Parliament, Statutory Instrument, Directive or Regulation of the European Union, British, European or International Standard, Code of Practice, manufacturers' instructions or similar publication, are references to such publication in the form in which it was current at the date of this Certificate.

9.3 This Certificate will remain valid for an unlimited period provided that the product/system and the manufacture and/or fabrication including all related and relevant processes thereof:

- are maintained at or above the levels which have been assessed and found to be satisfactory by the BBA
- continue to be checked as and when deemed appropriate by the BBA under arrangements that it will determine
- are reviewed by the BBA as and when it considers appropriate.

9.4 In granting this Certificate, the BBA is not responsible for:

- the presence or absence of any patent, intellectual property or similar rights subsisting in the product/system or any other product/system
- the right of the Certificate holder to manufacture, supply, install, maintain or market the product/system
- individual installations of the product/system, including the nature, design, methods and workmanship of or related to the installation
- the actual works in which the product/system is installed, used and maintained, including the nature, design, methods and workmanship of such works.

9.5 Any information relating to the manufacture, supply, installation, use and maintenance of this product/system which is contained or referred to in this Certificate is the minimum required to be met when the product/system is manufactured, supplied, installed, used and maintained. It does not purport in any way to restate the requirements of the Health & Safety at Work etc Act 1974, or of any other statutory, common law or other duty which may exist at the date of this Certificate; nor is conformity with such information to be taken as satisfying the requirements of the 1974 Act or of any statutory, common law or other duty of care. In granting this Certificate, the BBA does not accept responsibility to any person or body for any loss or damage, including personal injury, arising as a direct or indirect result of the manufacture, supply, installation, use and maintenance of this product/system.



In the opinion of the British Board of Agrément, Passivent Systems are fit for their intended use provided they are installed, used and maintained as set out in this Certificate. Certificate No 96/3273 is accordingly awarded to Passivent Ltd.

On behalf of the British Board of Agrément

Date of Third issue: 5th June 2007

A handwritten signature in black ink, appearing to read 'G. A. Cooper'.

Chief Executive

**Original Front Sheets issued 19th September 1996. This amended version includes reference to revised national Building Regulations, and new Conditions of Certification.*

Product

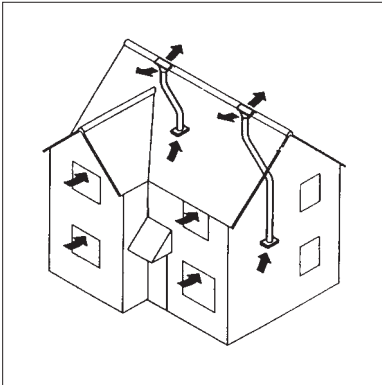

- THIS DETAIL SHEET RELATES TO THE PASSIVENT PSV SYSTEM.
- The system provides extract ventilation for occupants of new or existing dwellings or buildings of similar occupancy and condition.
- The system is designed to satisfy the principles of ventilation described in BRE Information Paper IP 13/94 Passive stack ventilation systems : design and installation.

This Detail Sheet must be read in conjunction with the Front Sheets, which give the product's position regarding the Building Regulations, general information relating to the product, and the Conditions of Certification respectively.

Technical Specification

1 Description

1.1 The Passivent PSV System comprises a number of components and relies on the stack effect and the effect of air passing over the roof to vent air from wet rooms, eg kitchens, bathrooms, WCs and utility rooms to the outside. The vented air is replaced by air from dry rooms that each have a window or wall-mounted air inlet (see Figures 1 and 2).

1.2 The system components are:

Air inlets

- Passivent External Canopy Grille Vent (PVCG4) — manufactured from aluminium with a polyester paint finish and plastic end caps, mounted on the outside of a straight window frame or head, or on a Passivent Overglass Vent Bar (PVOG). Used in conjunction with an internal Window Inlet Vent (PVFV4) or Window Inlet Humidity-Sensitive Vent (A101)
- Wall Inlet Fresh 90 — plastic internal and external grilles and tubular wall-sleeve
- Airbrick Grille (PV250) — manufactured in plastic. An adaptor is provided for use with the Wall Inlet Humidity-Sensitive Vent (A111) and cavity sleeve.

Air inlets — humidity-sensitive

Units include a humidity-sensitive element which controls the grille flap orientation and hence the area of the ventilation opening. Operating range is 47% to 65% relative humidity providing maximum ventilation only when humidity is high.

- Window Inlet Humidity-Sensitive Vent (A101) — a plastic body fitted internally to a straight window frame or head or on a Passivent Overglass Vent Bar (PVOG). Compatible with the external Canopy Grille (PVCG4)
- Wall Inlet Humidity-Sensitive Vent (A111) — a plastic body fitted internally on a wall and includes a cavity sleeve. The inlet, together with a cavity sleeve, is used in conjunction with an external Airbrick Grille (PV250) and adaptor
- Wall Inlet Humidity-Sensitive Fresh Humatic Vent (99 H) — plastic internal and external grilles and tubular-wall sleeve.

Air inlets — acoustic

- Wall Inlet Fresh 80 dB, Fresh 90 dB and Fresh 100 dB — similar to Fresh 90 but includes a sound absorbing lining to the wall sleeve.

Air inlets — acoustic and humidity-sensitive

- Wall Inlet Acoustic Humidity-Sensitive Vent (A111db) — same as the A111 vent but includes a sound absorbing lining to the wall sleeve
- Wall Inlet Acoustic Humidity-Sensitive Fresh Vent (99HdB) — same as the 99H vent but incorporates an integral sound absorbing lining to the wall sleeve.

Air extract

- Humidity-Sensitive Extract Vent (A161) — a plastic body incorporating the same humidity-sensitive element found in the humidity-sensitive air inlet vents. Fitted to the base of a duct connecting kitchens, bathrooms, WC or utility room to the outside.

Figure 1 Components

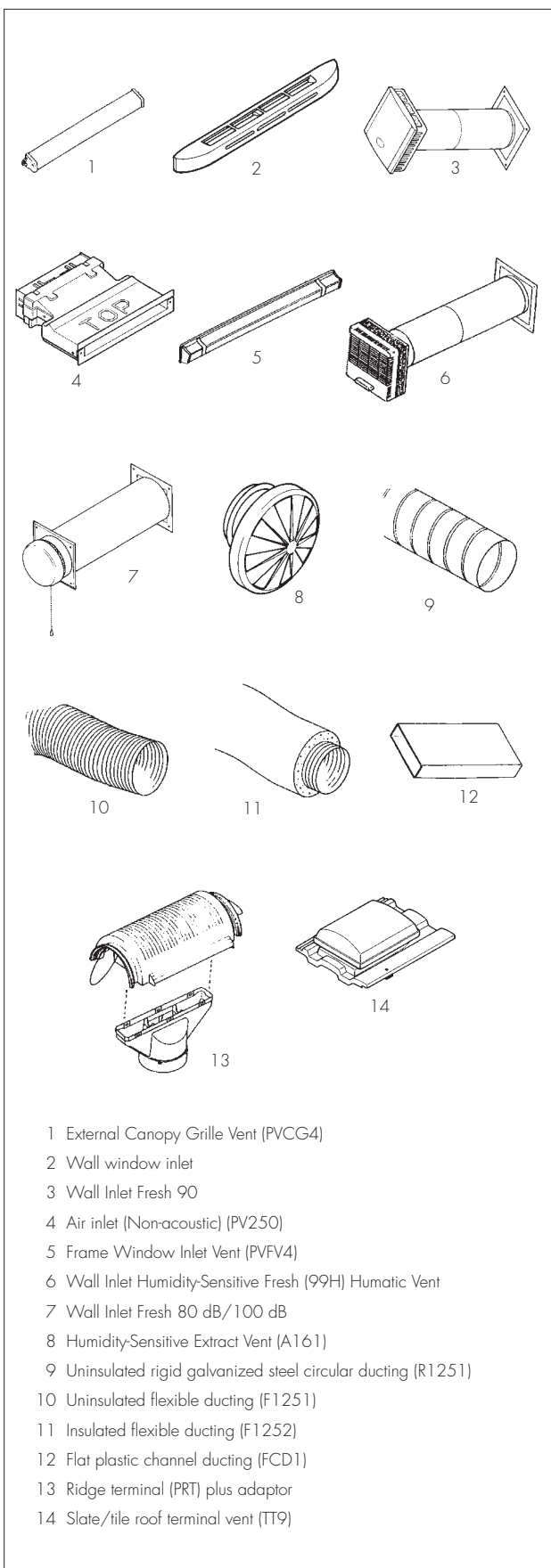
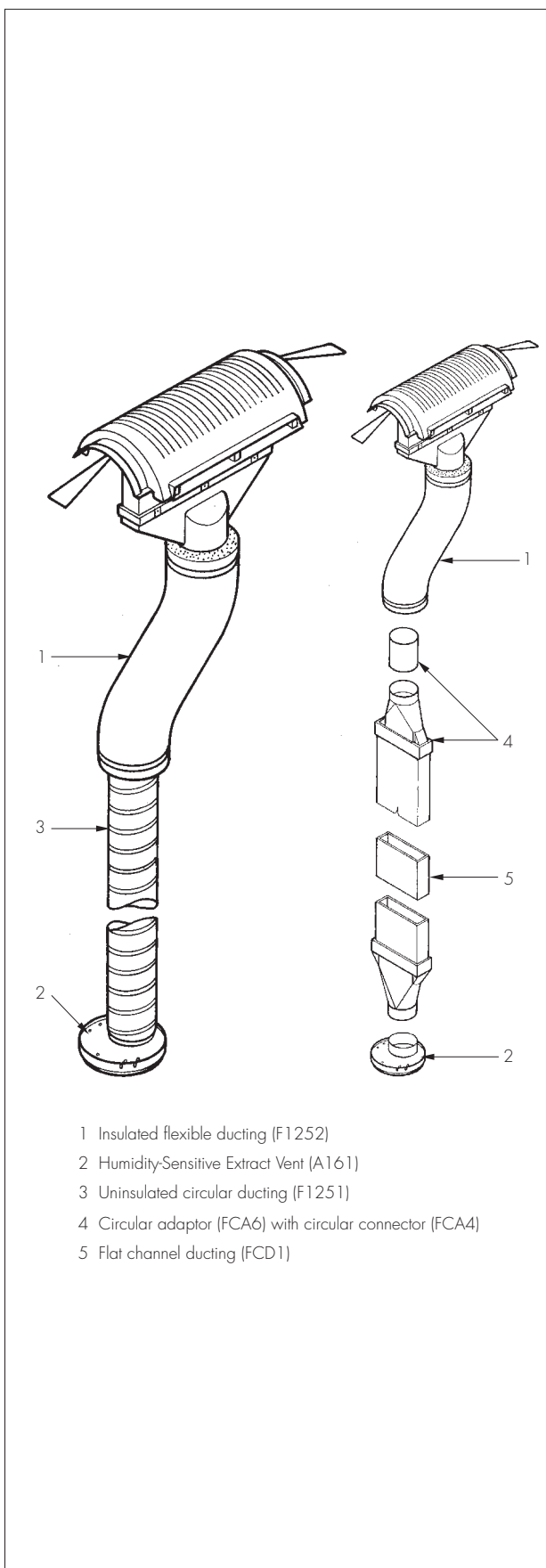

Figure 2 Ducting/terminals



Ducting

- rigid or flexible circular ducting (F1251) — available with an internal diameter of 125 mm. Flexible ducting (F1252) with 25 mm of insulation (thermal conductivity $\leq 0.04 \text{ Wm}^{-1}\text{K}^{-1}$), is provided for use in unheated parts of a building
- flat plastic channel ducting (FCD1), 204 mm by 60 mm — can be accommodated within a stud wall.

Roof terminals

- ridge terminals (PRT) — manufactured in ABS in a range of profiles with acrylic resin surface finishes
- slate/tile terminal vent (TT9) — manufactured in ABS in a range of profiles with acrylic resin surface finish. Used only at high level, a maximum 0.5 m down from the ridge.

Accessories

1.3 A range of accessories is available:

- Overglass Vent Bar (PVOG)
- acoustic wall cowl, for use with 99HdB
- air transfer wall grille (ATG1), for internal walls
- air transfer door grille (K145), for internal doors
- ductwork fire damper (FD125) and backplate (FD180)
- sleeved fire damper (FDA125)
- duct tape (X331)
- speedclamps (X332)
- circular ducting straight connector (MC01) (FC01)
- ridge terminal adaptor (G504), for use with circular ducts
- flat channel; rectangular/circular adaptor (FCA6), end cap (FCA2), straight connector (FCA3), wall plate (FCA5) and circular connector (FCA4).

Design Data

2 General

2.1 The Passivent System comprises separate ducts taken from the ceilings or walls of the kitchen, bathroom, WC and utility room to separate terminals on the roof (see Figure 3). The extract grille on the lower end of each duct includes a humidity controlled louvre which modulates the level of extraction dependent on the level of humidity. Wall- or window-mounted background ventilators are provided in the remaining rooms and, where necessary, internal grilles are used to aid airflow from the dry rooms to replace the air extracted from the wet rooms.

Figure 3 Typical layout

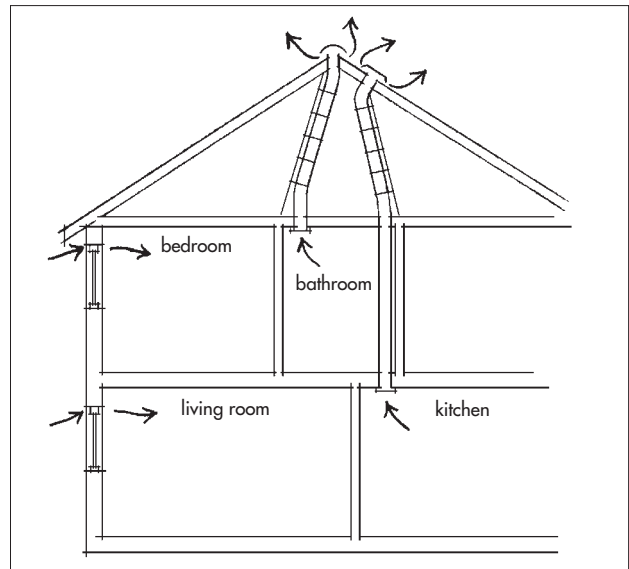

2.2 The system is designed to satisfy the principles of ventilation described in BRE Information Paper IP 13/94, including:

- separate ducting and outlets for each wet room to avoid crossflow
- design/location of ducting outlets to minimise risk of adverse airflow due to prevailing wind speed and direction
- maintaining vertical or near vertical ducting to minimise resistance to airflow.

2.3 Stack ventilation is recognised as an energy-efficient means of ventilation.

2.4 It is essential that the systems are designed and installed in accordance with this Certificate and the Certificate holder's instructions.

3 Ventilation



3.1 The system can provide adequate means of ventilation for people in a building. See:

England and Wales

Approved Document F, Table 1.2b and 1.4

Scotland

Mandatory Standard 3.14, clauses 3.14.1⁽¹⁾ and 3.14.6⁽¹⁾

(1) Technical Handbook Domestic.

Northern Ireland

Technical Booklet K, Note (1) to Table 3.2.

3.2 Ventilation performance is calculated in accordance with the design principles of CIBSE Guide A: *Environmental design*. The pressure driving the airflow is the sum of the wind and stack induced pressure which exceeds the sum of the duct loss and duct inlet and outlet loss. The Certificate holder provides a comprehensive design service for each building type to determine

adequate ventilation rates, taking into account the following parameters:

- internal/external temperature difference
- average wind velocity at roof terminal height
- pressure loss coefficients for ducts, inlet, outlet and extract grilles
- degree of shelter
- orientation of façade elements
- air leakage through gaps in building elements
- air inlet area through vents
- moisture vapour generation rates.



3.3 Air inlets are not required in 'wet' rooms but should otherwise be sited in accordance with the following provisions:

England and Wales

Approved Document F

Scotland

Regulation 9, Mandatory Standard 3.14, clauses 3.14.4⁽¹⁾, 3.14.5⁽¹⁾, 3.14.6⁽¹⁾ (see also section 1.1 of this Detail Sheet)

(1) Technical Handbook (Domestic).

Northern Ireland

Technical Booklet K.



3.4 Extract terminals should be located in the ceiling or on a wall less than 400 mm below the ceiling in accordance with

Approved Document F (Table 1.4).

4 Condensation



4.1 The use of the system will contribute to satisfying the requirements for limiting the risk of surface condensation in:

England and Wales

Approved Document C2(c)

Scotland

Mandatory Standard 3.15, clauses 3.15.1⁽¹⁾ and 3.15.3⁽¹⁾

(1) Technical Handbook (Domestic).

4.2 The risk of condensation is greatest when a building is drying out after construction. Guidance on preventing condensation from this and other sources is given in BRE Digest 369 *Interstitial condensation and fabric degradation* and in BRE report (BR 262 : 2002) *Thermal insulation : Avoiding risks*.

5 Behaviour in relation to fire



5.1 Ventilation grilles mounted on an internal wall or ceiling are of limited area and need not be taken into account when considering the classification of the lining's resistance to fire spread.



5.2 The use of wall-mounted air bricks or grilles in an otherwise protected area is unrestricted provided the minimum distances from other unprotected areas are maintained as given in:

England and Wales

Approved Document B, Diagram 20

Northern Ireland

Technical Booklet E, Diagram 4.4.



5.3 In Scotland, ventilators mounted on an external wall that is on a boundary or within 500 mm of a boundary must not project beyond the boundary. (See also section 10.2).



5.4 The introduction of slate or ridge vents in a traditional roof construction does not affect the normal AA rating of such a construction.

5.5 A single house is a single fire compartment, however, as for other services penetrating an element of construction, care should be taken to ensure that the edges of an opening in the floor are adequately constructed to ensure that the integrity of the remainder of the floor is maintained. However, in three-storey houses care should be taken not to prejudice escape routes, eg by encasing ductwork in half-hour fire-resistant boarding.

6 Noise

6.1 Noise ingress through external vents can in some circumstances be intrusive, for example close to busy roads or near airports. In such circumstances the use of sound attenuating ductwork should be considered at the design stage. In accordance to BS 5925 : 1991. Additional information can be found in CIBSE Guide B : 2005 *Heating, Ventilating, Air Conditioning, Refrigeration*, Sections 2, 3 and 12.

6.2 The acoustic air inlets achieve appreciable reductions in airborne sound transmission when compared to non-acoustic components. The results of sound insulation measurements to BS EN ISO 140-3 : 1995 are shown in Table 1.

Table 1 Airborne sound insulation

	Fresh 99H	A111	Fresh 80	Fresh 90
$D_{n,e,w}$ (dB)	45	41	46	43

7 Maintenance

7.1 In general, no maintenance will be required. However, periodic removal and washing of the extract grilles and filter is recommended. The humidity controlled lever which controls the grille flap orientation is pre-set in the factory and should not require adjustment.

7.2 There is little risk of blockage or damage to ducts and air terminals in normal use; however, should they occur, performance would be impaired. Occasional inspection, therefore, is recommended.

8 Durability



8.1 The components are made of durable materials and, should have a life equal to that of the building in which they are installed.

8.2 During the lifetime of externally mounted products some fading should be expected due to UV degradation but this will not affect the product's performance.

8.3 Data obtained by the BBA show that the humidity-sensitive control element retains its properties when subject to accelerated conditions of grease vapour and dust accumulation. Assessments of performance in use also support the element's durability.

Installation

9 General

9.1 Installation of the Passivent System must comply with the provisions of this Certificate and the Certificate holder's instructions and preferably be carried out by a Passivent Mastercare trained installer holding a current certificate issued by the Certificate holder.

9.2 The Certificate holder provides a comprehensive design service and layout plans for each project.

10 Procedure

10.1 Air inlets must be appropriately sited on external walls or windows. Ventilator sleeves in wall-mounted inlets should be installed with a slight downward tilt to the outside.

10.2 Systems are more effective if they are placed in the ceiling or wall near (but not directly over) a cooker. The positioning of the duct that runs from the kitchen ceiling is usually constrained by the layout of the rooms above, since the duct needs to run either in a corner, where it can be boxed in, or in a cupboard or stud partition wall. If the extract is not near the cooker it should preferably be away from the window, on the opposite side of the

cooker. Each extract must have its own duct running to the roof. For buildings subject to the Building (Scotland) Regulations, a fire damper is installed behind the extract, unless the ducting is non-combustible, or encased in half-hour fire-resistant boarding.

10.3 All ductwork should be as near vertical as possible, take the shortest possible path and be firmly secured. Care should be taken to ensure flexible ducting does not sag and has smooth bends. Insulated ductwork must be used in unheated spaces. No section of duct should be at an angle of more than 45° to the vertical and have no more than two bends per duct.

10.4 Ridge terminals must be sited to allow as near vertical duct runs as possible. Where ridge terminals are not practical, slate/tile terminals may be used, but they must be as close to the ridge as possible and a maximum of 0.5 m down.

Technical Investigations

The following is a summary of the technical investigations carried out on the Passivent System.

11 Investigations

11.1 An examination was made of data relating to:

- airflow characteristics
- resistance to rain ingress
- effect of UV and heat ageing
- resistance to impact
- durability of humidity sensing element
- acoustic performance.

11.2 The fabrication process and the assembly procedure, including the methods adopted for factory production control, were examined and found satisfactory by the BBA.

11.3 Visits to sites were conducted and the practicability of installation assessed.

11.4 A survey of users of the system was conducted.

11.5 The effect of the installation of the system on security against intrusion was assessed.

Bibliography

BS 5925 : 1991 *Code of practice for ventilation principles and designing for natural ventilation*

BS EN ISO 140-3 : 1995 *Acoustics — Measurement of sound insulation in buildings and of building elements — Laboratory measurements of airborne sound insulation of building elements*



On behalf of the British Board of Agrément

Head of Approvals
— Physics

Chief Executive

Date of Fourth issue: 20 July 2009

**Original Detail Sheet issued 19th September 1996. This amended version includes clarification of the reference to the England and Wales Building Regulations.*

Product

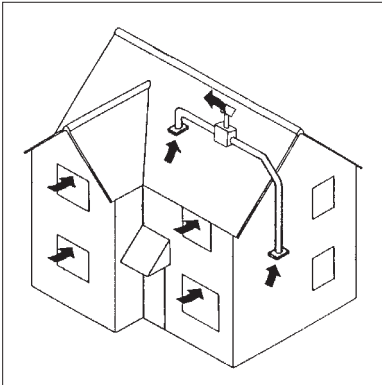

- THIS DETAIL SHEET RELATES TO THE PASSIVENT AV SYSTEM.
- The system provides extract ventilation for occupants of new or existing dwellings or flats, or buildings of similar occupancy and condition.
- The system provides assisted ventilation via ducting and a centrally located continuously running fan.

This Detail Sheet must be read in conjunction with the Front Sheets, which give the product's position regarding the Building Regulations, general information relating to the product, and the Conditions of Certification, respectively.

Technical Specification

1 Description

1.1 The Passivent AV System comprises a number of components and includes a continuously running fan to vent air from wet rooms, eg kitchens, bathrooms, WCs and utility rooms to the outside. The vented air is replaced by air from dry rooms which each have a window or wall-mounted air inlet (see Figure 1).

1.2 The system components are:

Extract fans

- The Passivent Central Extract Fan A151 — comprises a continuously running 65 watt fan rated up to 300 m³h⁻¹. A 125 mm diameter inlet spigot is connected to the extract fan via ducting and a single 150 mm diameter outlet spigot is connected to the roof terminal via ducting.

Air inlets

- Passivent External Canopy Grille Vent (PVCG4) — manufactured from aluminium with a polyester paint finish and plastic end caps, mounted on the outside of a straight window frame or head, or on a Passivent Overglass Vent Bar (PVOG). Used in conjunction with an internal Window Inlet Vent (PVFV4) or Window Inlet Humidity-Sensitive Vent (A101)
- Wall Inlet Fresh 90 — polystyrene 3630 internal and external grilles and tubular wall-sleeve
- Airbrick Grille (PV250) — manufactured in plastic. An adaptor is provided for use with the

Wall Inlet Humidity-Sensitive Vent (A111) and cavity sleeve.

Air inlets — humidity-sensitive

Units include a humidity-sensitive element which controls the grille flap orientation and hence the area of the ventilation opening. Operating range is 47% to 65% relative humidity providing maximum ventilation only when humidity is high:

- Window Inlet Humidity-Sensitive Vent (A101) — a polystyrene body fitted internally to a straight window frame or head or on a Passivent Overglass Vent Bar (PVOG). Compatible with the external Canopy Grille (PVCG4)
- Wall Inlet Humidity-Sensitive Vent (A111) — a polystyrene body fitted internally on a wall and includes a cavity sleeve. The inlet, together with a cavity sleeve, is used in conjunction with an external Airbrick Grille (PV250) and adaptor
- Wall Inlet Humidity-Sensitive Fresh Humatic Vent (99H) — plastic internal and external grilles and tubular-wall sleeve.

Air inlets — acoustic

- Wall Inlet Fresh 80 dB, Fresh 90 dB and Fresh 100 dB — similar to Fresh 90, but includes a sound absorbing lining to the wall sleeve.

Air inlets — acoustic and humidity-sensitive

- Wall Inlet Acoustic Humidity-Sensitive Vent (A111dB) — same as the A111 but includes a sound absorbing lining to the wall sleeve
- Wall Inlet Acoustic Humidity-Sensitive Fresh Vent (99HdB) — same as the 99H vent but incorporates an integral sound absorbing lining to the wall sleeve.

Figure 1 Components

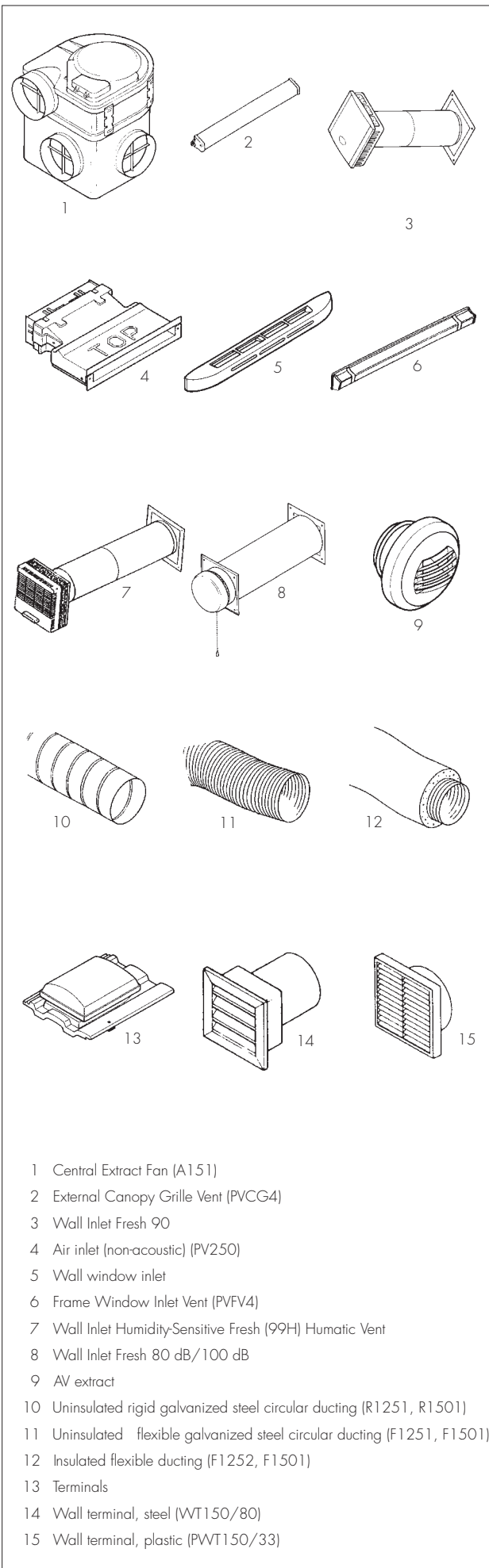

Air extract

- Humidity-Sensitive Extract Vent (A121, A133) — a polystyrene 3630 body incorporating the same humidity-sensitive element found in the humidity-sensitive air inlet vents. Fitted on walls or ceilings and connecting wet rooms to the outside via ductwork and central extract fan
- the A121 model is often sited in bathrooms and kitchens (extract rate 15–75 m³h⁻¹)
- the A133 model incorporates an electrically powered boost control with remote switch (allowing extract rates of up to 150 m³h⁻¹ for 30 minutes)
- the A141 model is often sited in separate WCs (individual extract rates to provide either 15, 30, 45 or 60 m³h⁻¹).

Ducting

- rigid or flexible circular ducting (R1251 and F1251) — available with an internal diameter of 125 mm
- rigid or flexible circular ducting (R1501 and F1501) — available with an internal diameter of 150 mm
- flexible ducting (F1252 and F1502) with 25 mm of insulation $\leq 0.040 \text{ Wm}^{-1}\text{K}^{-1}$, is provided for use in unheated parts of a building.

Roof terminals

- slate/tile terminal vent (TT13) — manufactured in plastic in a range of profiles with acrylic resin surface finish.

Wall terminals

- wall terminal (PWT 150/80) — a galvanized steel external grille and tubular wall sleeve, mounted on walls or gable ends
- wall terminal (WT 150/33) — a plastic external grille and tubular wall sleeve, mounted in walls or gable ends.

Accessories

1.3 A range of accessories is available:

- Overglass Vent Bar (PVOG)
- acoustic wall cowl, for use with 99HdB
- air transfer wall grille (ATG1), for internal walls
- air transfer door grille (K145), for internal doors
- straight sleeve couplings, 125 mm and 150 mm diameter duct (MCO1, MC02, FC01 and FC02)
- 90° bends for 125 mm and 150 mm diameter duct (B9001 and B9002)
- equal Tee junctions 125 mm and 150 mm diameter duct (ET01 and ET02)
- straight reducer, 150 mm to 125 mm diameter duct (RD0201)
- reducing Tee junction, 125 mm onto 150 mm diameter duct (RT0201)

- staggered cross piece, 125 mm onto 150 mm diameter duct (STO201)
- ductwork fire damper (FD125 and FD150) and backplate (FD180)
- sleeved fire damper (FDA125 and FDA150)
- duct tape (X331)
- speedclamps (X332).

Design Data

2 General

2.1 The Passivent AV System comprises ducts taken from the ceilings or walls of the kitchen, bathroom, WC and utility room to roof- or wall-mounted external grilles via a centrally-located extract fan (see Figure 2). The extract grille on the lower end of each duct includes a humidity controlled flap which modulates the level of extraction dependent on the level of humidity. Wall- or window-mounted background ventilators are provided in the remaining rooms and, where necessary, internal grilles are used to aid airflow from the dry rooms to replace the air extracted from the wet rooms.

Figure 2 Typical layout

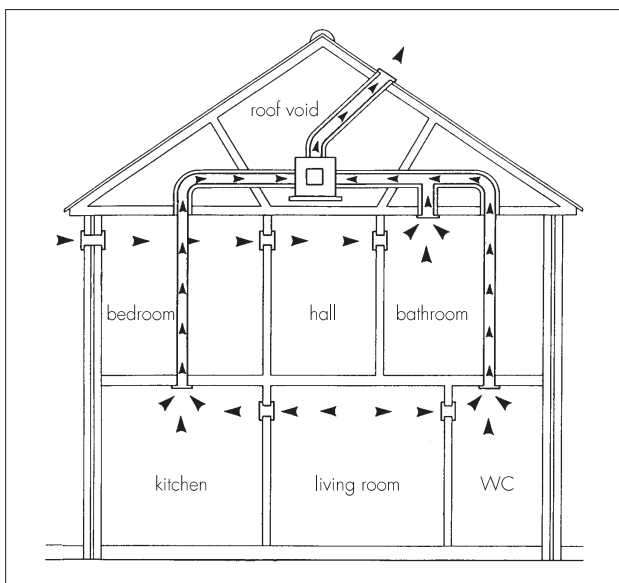

2.2 The system is suitable for houses and flats with the duct system and terminal fittings sized to take account of the required air flow rate and fan pressure performance.

2.3 It is essential that the systems are designed and installed in accordance with this Certificate and the Certificate holder's instructions.

3 Ventilation

 3.1 The system can provide adequate means of ventilation for people in a building. See:

England and Wales

Approved Document F, Tables 1.2b, 1.4 and Appendix E

Scotland

Mandatory Standard 3.14, clauses 3.14.1⁽¹⁾ and 3.14.6⁽¹⁾

(1) Technical Handbook (Domestic).

Northern Ireland

Technical Booklet K, Note (1) to Table 3.2.

3.2 Ventilation performance is calculated in accordance with the design principles of CIBSE Guide A : 2006 *Environmental design*. The pressure driving the airflow is the fan pressure which exceeds the sum of the duct loss and duct inlet and outlet loss. The Certificate holder provides a comprehensive design service for each building type to determine adequate ventilation rates.

 3.3 Extract terminals should be located in the ceiling or on a wall less than 400 mm below the ceiling in accordance with Approved Document F (Table 1.4).

 3.4 Air inlets are not required in 'wet' rooms but should otherwise be sited in accordance with the provisions given in:

England and Wales

Approved Document F

Northern Ireland

Technical Booklet K.

4 Condensation

 4.1 The use of the system will contribute to satisfying the requirements for limiting the risk of surface condensation in:

England and Wales

Approved Document C2(c)

Scotland

Mandatory Standard 3.15, clauses 3.15.1⁽¹⁾ and 3.15.3⁽¹⁾

(1) Technical Handbook (Domestic).

4.2 The risk of condensation is greatest when a building is drying out after construction. Guidance on preventing condensation from this and other sources is given in BRE Digest 369 *Interstitial condensation and fabric degradation* and in BRE report (BR 262 : 2002) *Thermal insulation : avoiding risks*.

5 Behaviour in relation to fire

 5.1 Ventilation grilles mounted on an internal wall or ceiling are of limited area and need not be taken into account when

considering the classification of the lining's resistance to fire spread.



5.2 The use of wall-mounted air bricks or grilles in an otherwise protected area is unrestricted provided the minimum distances from other unprotected areas are maintained as given in:

England and Wales

Approved Document B, Diagram 20

Northern Ireland

Technical Booklet E, diagram 4.4.



5.3 In Scotland, ventilators mounted on an external wall that is on a boundary or within 500 mm of a boundary must not project beyond the boundary. See also section 11.2.



5.4 The introduction of slate or ridge vents in a traditional roof construction does not affect the normal AA rating of such a construction.

5.5 A single house is a single fire compartment and ductwork may be treated like any other service, with no special precautions. However, in three-storey houses care should be taken not to prejudice escape routes, eg by encasing ductwork in half-hour fire-resistant boarding.



5.6 Where ducting has to penetrate a separating wall or floor care must be taken to ensure that the penetration has a period of fire resistance no less than that required for the wall or floor. Suitable fire dampers are available for this purpose.

6 Noise

6.1 Fan generated noise is minimal under normal operating conditions and will not exceed suggested design background noise levels in Table 1 of BRE Digest 398 *Continuous mechanical ventilation in dwellings*. When mounting the fan, care must be taken to isolate it from the building structure and ducting should be sized to keep air flows below approximately 4 ms^{-1} .

6.2 Noise ingress through external vents can in some circumstances be intrusive, for example close to busy roads or near airports. In such circumstances the use of sound attenuating ductwork should be considered at the design stage. Additional information can be found in CIBSE Guide B : 2005 *Heating, Ventilating, Air Conditioning, Refrigeration*

6.3 The acoustic air inlets achieve appreciable reductions in airborne sound transmission when compared to non-acoustic components. The results of sound insulation measurements to BS EN ISO 140-3 : 1998 are shown in Table 1.

Table 1 Airborne sound insulation

	Fresh 99 H	A111	Fresh 80	Fresh 90
$D_{n,e,w}$ (dB)	45	41	46	43

7 Provision of an electrical supply

7.1 For electrical safety, provision of an electrical supply and the connection of the unit to the supply should be carried out by a qualified electrician.

7.2 The A133 extract is connected to a suitable main electrical supply.

7.3 The control unit should be connected to a suitable mains electrical supply through a fused double-pole isolating switch. A fuse rated at a maximum of 3 amps should be used.

7.4 In England and Wales, all installations must meet the requirements of The Building Regulations 2000 (as amended) (England and Wales), Part P — *Electrical Safety*. Notification should be made to the Local Authority Building Control in advance of installation. As an alternative to this procedure, electrical connections can be carried out by a person registered with a government-approved competent persons scheme for electrical work, such as the Electrical Self-Assessment Scheme (ELECSEA), using materials suitable for the purpose.

7.5 In Scotland, to meet the requirements of Mandatory Standard 4.5, with reference to clause 4.5.1⁽¹⁾ of The Building (Scotland) Regulations 2004 (as amended), all installations should be designed, constructed and tested such that they are in accordance with the requirements of BS 7671 : 2001.

(1) Technical Handbook — (Domestic).

8 Maintenance

8.1 When the fan is mounted care should be taken to ensure that it remains accessible for maintenance. The fans are fitted with a sealed-for-life bearing not requiring maintenance or lubrication.

8.2 In general, maintenance will not be required to other components. The humidity controlled lever which controls the grille flap orientation is pre-set in the factory and should not require adjustment.

8.3 There is little risk of blockage or damage to ducts and air terminals in normal use, however, should they occur, performance would be impaired. Occasional inspection, therefore, is recommended.

9 Durability



9.1 The components are made of durable materials and, if installed in accordance with the provisions of this Certificate, should have a life equal to that of the building in which they are installed.

9.2 During the lifetime of externally mounted products some fading should be expected due to UV degradation but this will not affect the product's performance.

9.3 Data obtained by the BBA show that the humidity-sensitive control element retains its properties when subject to accelerated conditions of grease vapour and dust accumulation. Assessments of performance in use also support the element's durability.

Installation

10 General

10.1 Installation of the Passivent AV System must comply with the provisions of this Certificate and the Certificate holder's instructions and preferably be carried out by a Passivent Mastercare trained installer holding a current certificate issued by the Certificate holder.

10.2 The Certificate holder provides a comprehensive design service and layout plans for each project.

11 Procedure

11.1 Air inlets must be appropriately sited on external walls or windows. Ventilator sleeves in wall-mounted inlets should be installed with a slight downward tilt to the outside.

11.2 Systems are more effective if they are placed in the ceiling or wall near (but not directly over) a cooker. If the extract is not near the cooker it should preferably be away from the window, on the opposite side of the cooker. Each extract must have its own duct running directly or via other extract ducting (see Figure 2) to the central fan. For buildings subject to the Building (Scotland) Regulations, a fire damper is installed behind the extract, unless the ducting is non-combustible, or encased in half-hour fire-resistant boarding.

11.3 All ductwork should be firmly secured and joints well taped. Insulated ductwork must be used in unheated spaces. Spigot connections must be taped and speedclamped.

11.4 Outlet terminals must be sited away from windows and ventilation inlets, preferably more than 2 m distant.

Technical Investigations

The following is a summary of the technical investigations carried out on the Passivent AV System.

12 Tests

Tests carried out to determine durability of new inlet.

13 Investigations

13.1 An examination was made of data relating to:

- fan performance
- electrical safety
- airflow characteristics
- resistance to rain ingress
- effect of UV and heat ageing
- resistance to impact
- durability of humidity sensing element
- acoustic performance.

13.2 The fabrication process and the assembly procedure, including the methods adopted for factory production control, were examined and found satisfactory by the BBA.

13.3 Visits to sites were conducted and the practicability of installation assessed.

13.4 A survey of users of the system was conducted.

13.5 The effect of the installation of the system on security against intrusion was assessed.

Bibliography

BS 7671 : 2001 *Requirements for electrical installations. IEE Wiring Regulations. Sixteenth Edition*

BS EN ISO 140-3 : 1995 *Acoustics — Measurement of sound insulation in buildings and of building elements — Laboratory measurement of airborne sound insulation of building elements*



On behalf of the British Board of Agrément

Head of Approvals
— Physics

Chief Executive

Date of Fourth issue: 20 July 2009

**Original Detail Sheet issued 19th September 1996. This amended version includes clarification of the reference to the England and Wales Building Regulations.*