

Tremco illbruck Ltd

Bentall Business Park
Glover
Washington
Tyne and Wear NE37 3JD

Tel: 0191-419 0505 Fax: 0191-419 2200
e-mail: sales@tremco-illbruck.co.uk
website: www.tremco-illbruck.com



Agrément Certificate
No 97/3331

PRODUCT SHEET 1 – COMPRIBAND SUPER

PRODUCT SCOPE AND SUMMARY OF CERTIFICATE

This Certificate relates to Compriband Super for use as a weathertight seal in structural and expansion joints in new or existing joints in structural units of timber, plastics, masonry, metal or concrete.

AGRÉMENT CERTIFICATION INCLUDES:

- factors relating to compliance with Building Regulations where applicable
- factors relating to additional non-regulatory information where applicable
- independently verified technical specification
- assessment criteria and technical investigations
- design considerations
- installation guidance
- regular surveillance of production
- formal three-yearly review.



KEY FACTORS ASSESSED

Weathertightness the product will resist the passage of wind-driven rain, snow, run-off water and dust into the interior of the building (see section 4).

Durability — the product has a service life of up to 25 years (see section 5).

The BBA has awarded this Agrément Certificate for Compriband Super to Tremco illbruck Ltd as fit for its intended use provided it is installed, used and maintained as set out in this Agrément Certificate.

On behalf of the British Board of Agrément

Date of First issue: 19 February 1997

Date of Third issue: 28 March 2008

Head of Approvals
— Materials

Chief Executive

The BBA is a UKAS accredited certification body — Number 113. The schedule of the current scope of accreditation for product certification is available in pdf format via the UKAS link on the BBA website at www.bbacerts.co.uk

Readers are advised to check the validity and latest issue number of this Agrément Certificate by either referring to the BBA website or contacting the BBA direct.

British Board of Agrément
Bucknalls Lane
Garston, Watford
Herts WD25 9BA

©2008

tel: 01923 665300
fax: 01923 665301
e-mail: mail@bba.star.co.uk
website: www.bbacerts.co.uk

Regulations

In the opinion of the BBA, Compriband Super, if used in accordance with the provisions of this Certificate, will meet or contribute to meeting the relevant requirements of the following Building Regulations:



The Building Regulations 2000 (as amended) (England and Wales)

Requirement:	C2(a)(b)	Resistance to moisture
Comment:		The product will contribute to a wall meeting this Requirement. See sections 4.1 and 4.2 of this Certificate.
Requirement:	Regulation 7	Materials and workmanship
Comment:		The product is acceptable. See section 5 and the <i>Installation</i> part of this Certificate



The Building (Scotland) Regulations 2004 (as amended)

Regulation:	8(1)	Fitness and durability of materials and workmanship
Comment:		The use of the product satisfies the requirements of this Regulation. See section 5 and the <i>Installation</i> part of this Certificate.
Regulation:	9	Building standards – construction
Standard:	3.10	Precipitation
Comment:		The product will contribute to satisfying this Standard, with reference to clauses 3.10.1 ⁽¹⁾⁽²⁾ and 3.10.7 ⁽¹⁾⁽²⁾ of this Standard. See sections 4.1 and 4.2 of this Certificate.
Regulation:	12	Building standards – conversions
Comment:		All comments given for this product under Regulation 9, also apply to this Regulation, with reference to clause 0.12.1 ⁽¹⁾⁽²⁾ and Schedule 6 ⁽¹⁾⁽²⁾ . (1) Technical Handbook (Domestic). (2) Technical Handbook (Non-Domestic).



The Building Regulations (Northern Ireland) 2000 (as amended)

Regulation:	B2	Fitness of materials and workmanship
Comment:		The product is acceptable. See section 5 and the <i>Installation</i> part of this Certificate.
Regulation:	C4	Resistance to ground moisture and weather
Comment:		The product will contribute to a wall satisfying this Regulation. See sections 4.1 and 4.2 of this Certificate.

Construction (Design and Management) Regulations 2007

Construction (Design and Management) Regulations (Northern Ireland) 2007

Information in this Certificate may assist the client, CDM co-ordinator, designer and contractors to address their obligations under these Regulations.

See section: 1 *Description* (1.2).

Non-regulatory Information

NHBC Standards 2007

NHBC accepts the use of Compriband Super, when installed and used in accordance with this Certificate, in relation to *NHBC Standards*, Chapter 6.1, *External masonry walls*, Chapter 6.2, *External timber framed walls*, Chapter 6.9, *Curtain walling and cladding*.

Zurich Building Guarantee Technical Manual 2007

In the opinion of the BBA, the use of Compriband Super, in relation to this Certificate, is not subject to the requirements of this Technical Manual.

General

This Certificate relates to Compriband Super for use as a weathertight seal in structural and expansion joints in new or existing joints in structural units of timber, plastics, masonry, metal or concrete.

1 Description

1.1 Compriband Super is designed to form a primary weather seal. It is manufactured from blocks of soft polyester urethane foam cut sheet, evenly impregnated with a mixture of acrylic resin compound, tackifiers and UV blocking pigments. An adhesive layer is applied during the process to one side of the material to aid final installation. The impregnated foam is then compressed by approximately 85% before forming into rolls, and cutting to the required size.

1.2 Dimensions of the tapes are given in Table 1. Any width (ie joint depth) can be supplied up to 600 mm. Alternative widths are available to suit individual requirements.

Table 1 Tape dimensions⁽¹⁾

Size	Gap size (mm)	Recommended tape width joint depth (mm)	Fully expanded thickness (mm)	Roll length (m)
2	2	10	10	8
3	2-3	10	15	6
4	3-4	15	20	6
5	4-5	15	25	4
6	5-6	15	30	4
8	7-8	20	40	4
10	9-10	25	50	4
12	10-12	30	60	4
16	14-16	40	80	3
20	17-20	50	100	3
25	22-25	60	125	3

(1) The table assumes that the material is used under 80% compression for a full weather seal. Lower compression ratios may be suitable for less demanding applications. Gaps of greater than 25 mm may be sealed using two or three sections of tape laminated together, the Certificate holder's advice must be sought.

1.3 When installed into a joint the tape begins to expand and fill the gap (see Figure 1). The expanding tape accommodates undulating surface irregularities in the joint. To provide a weather seal the material should be used under 80% compression.

Figure 1 Typical tape installation

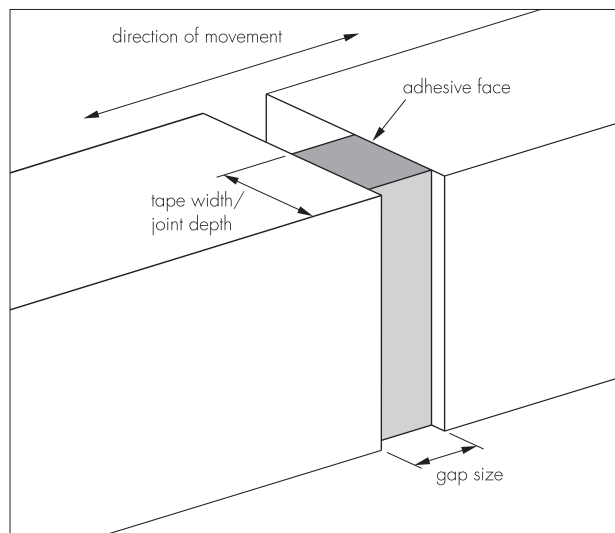

1.4 When on the roll, the adhesive layer is protected by a siliconised release liner.

1.5 Quality control checks are carried out on the foam, impregnating mixture and on the finished product.

2 Delivery and site handling

2.1 Tapes are supplied in pre-compressed rolls, interleaved between siliconised paper. Tapes are delivered in cartons (the contents vary according to size of tapes) bearing the manufacturer's name, a detailed description of the contents and an adhesive label bearing the BBA identification mark incorporating the number of this Certificate.

2.2 Tapes should be stored horizontally in cool, dry conditions in the original packaging; excessive weight should not be placed on the cartons.

Assessment and Technical Investigations

The following is a summary of the assessment and technical investigations carried out on Compriband Super.

Design Considerations

3 Use

Compriband Super is satisfactory for use to provide a weather seal to structural and expansion joints, and in new or existing joints in structural units of timber, plastics, masonry, metal or concrete.

4 Weathertightness



4.1 To achieve optimum resistance to water penetration, the tape should be used under 80% compression, i.e. the tape thickness is five times the gap size to be sealed.

4.2 The tapes are not designed to withstand a head of water, the advice of the Certificate holder should be sought, where this is required.

5 Durability



On the basis of data from accelerated laboratory tests and performance in service, a service life of up to 25 years is anticipated.

Installation

6 General

6.1 Installation of Compriband Super must be carried out in accordance with the manufacturer's instructions. Compriband Super may be installed in all conditions likely to occur in practice; however, care should be taken when used at lower ambient temperatures (see section 6.3).

6.2 Joints must be clean and free from debris, eg dirt, mortar residue, likely to obstruct adhesion. The inner surfaces of the joints to be filled should be as smooth as possible. To achieve a perfect seal in masonry the changes in level at mortar joints must be as small as possible.

6.3 The tape will start to re-expand gradually as soon as it is unwound from the roll. The rate of re-expansion is temperature dependent (see Table 2). At low ambient temperatures the rate of recovery after installation can be accelerated by the gentle application of heat from an indirect heat source. At high ambient temperatures the tapes should be stored in a cool environment (fridge or freezer) to retard expansion immediately prior to installation.

Table 2 Approximate recovery time to 80% compression

Temperature(°C)	Recovery time to 80% compression
3	10 hours
10	2 hours
20	5 mins
30	2 mins

7 Procedure

7.1 The size of tape needed is determined by the dimensions of the gap. The tape width (joint depth) should not be less than the recommendation shown in Table 1.

7.2 When using the tapes to seal between prefabricated units during construction, the seal must be attached to the unit already in position. The adjoining unit can then be fitted.

7.3 Joints should be designed and the tapes positioned so that differential movement between panels does not tend to force the product out of the joint.

7.4 The product can be cut using scissors or a knife.

7.5 The product should be jointed by using excess length and forming tight butt joints, apart from very small sections where overlapping can be used (see Figure 2).

7.6 The silicone release paper must be removed and the tape positioned in the joint before significant expansion of the tape occurs.

7.7 Care must be taken not to stretch the material at any point, especially at intersections. The product should be cut overlapped at corners to ensure that it can expand without restriction (see Figure 3 and 4).

Figure 2 Joint detail

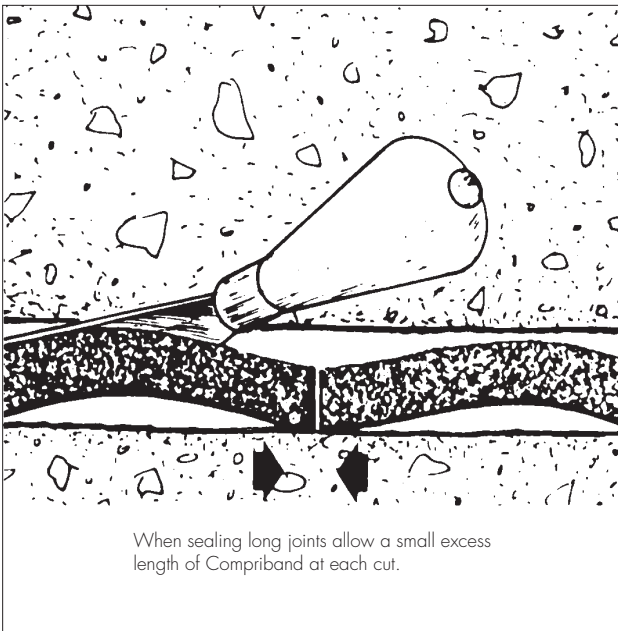

Figure 3 Intersection detail

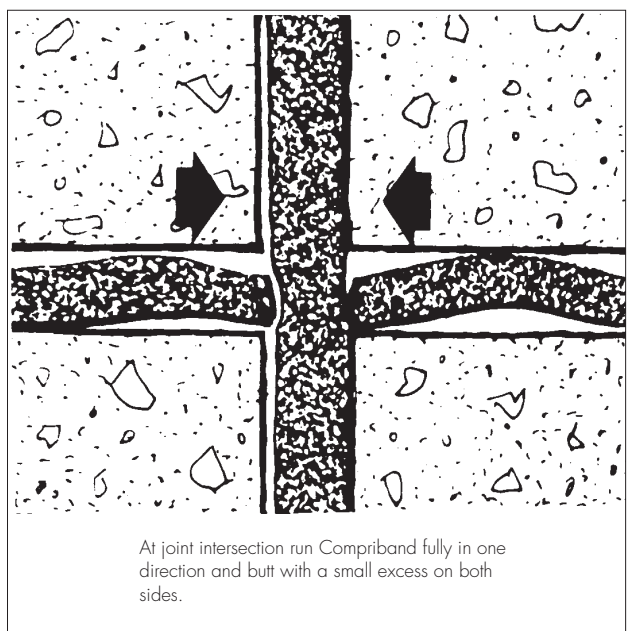
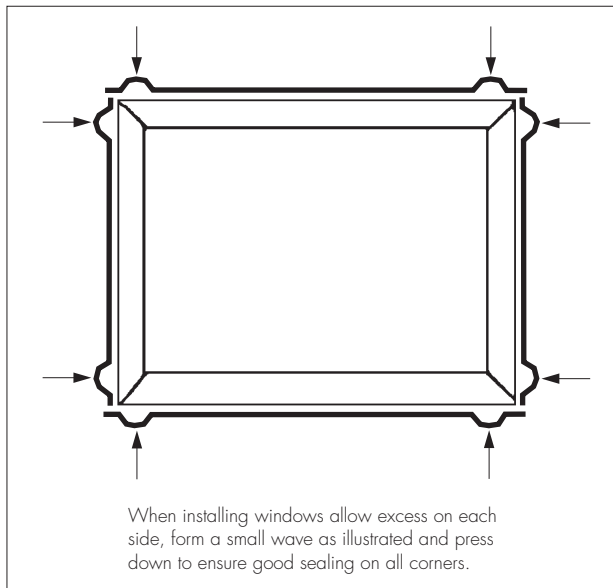

Figure 4 Corner detail



Technical Investigations

8 Tests

Tests were carried out in Germany by the Hessian Agricultural Experimental Establishment in Darmstadt, MPA Nordrhein Westfalen, and the Institute of Building Materials Science and Materials Testing at Hanover University. The results of the tests, which are typical values for the material, are summarised in Table 3.

Table 3 Physical properties of foam prior to impregnation — general

Test (units)	Result	Method ⁽¹⁾
Tensile strength (Nmm ⁻²)	0.16	DIN 53571
Elongation at break (%)	188	DIN 53571
Density of foam (kgm ⁻³)	38.5	

(1) The test documents are detailed in the *Bibliography*.

9 Investigations

9.1 A factory inspection was carried out to assess and examine the manufacturing process and quality control methods.

9.2 An investigation was carried out of test data obtained by a Dutch Agrément body (KOMO) on Compriband Super. The data from the following tests were found to be acceptable:

- dimensions
- distribution of impregnation agent
- resistance to water, salts and alkaline environments
- resistance to deformation
- effect on building materials.
- resistance to low temperature breakage
- resistance to UV ageing
- resistance to wind-driven rain

9.3 Compriband Super shares common raw materials with Compriband 600, (Agrément Certificate No 96/3309). Test data relating to Compriband 600 where applicable has been used as supporting evidence to complete the technical investigations for Compriband Super.

Bibliography

DIN 53571 : 1978 *Testing of flexible cellular materials; Tensile strength testing, determination of tensile strength and elongation at break*

10 Conditions

10.1 This Certificate:

- relates only to the product/system that is named and described on the front page
- is granted only to the company, firm or person named on the front page — no other company, firm or person may hold or claim any entitlement to this Certificate
- is valid only within the UK
- has to be read, considered and used as a whole document — it may be misleading and will be incomplete to be selective
- is copyright of the BBA
- is subject to English law.

10.2 References in this Certificate to any Act of Parliament, Statutory Instrument, Directive or Regulation of the European Union, British, European or International Standard, Code of Practice, manufacturers' instructions or similar publication, are references to such publication in the form in which it was current at the date of this Certificate.

10.3 This Certificate will remain valid for an unlimited period provided that the product/system and the manufacture and/or fabrication including all related and relevant processes thereof:

- are maintained at or above the levels which have been assessed and found to be satisfactory by the BBA
- continue to be checked as and when deemed appropriate by the BBA under arrangements that it will determine
- are reviewed by the BBA as and when it considers appropriate.

10.4 In granting this Certificate, the BBA is not responsible for:

- the presence or absence of any patent, intellectual property or similar rights subsisting in the product/system or any other product/system
- the right of the Certificate holder to manufacture, supply, install, maintain or market the product/system
- individual installations of the product/system, including the nature, design, methods and workmanship of or related to the installation
- the actual works in which the product/system is installed, used and maintained, including the nature, design, methods and workmanship of such works.

10.5 Any information relating to the manufacture, supply, installation, use and maintenance of this product/system which is contained or referred to in this Certificate is the minimum required to be met when the product/system is manufactured, supplied, installed, used and maintained. It does not purport in any way to restate the requirements of the Health & Safety at Work etc Act 1974, or of any other statutory, common law or other duty which may exist at the date of this Certificate; nor is conformity with such information to be taken as satisfying the requirements of the 1974 Act or of any statutory, common law or other duty of care. In granting this Certificate, the BBA does not accept responsibility to any person or body for any loss or damage, including personal injury, arising as a direct or indirect result of the manufacture, supply, installation, use and maintenance of this product/system.

