



Freefoam Plastics Limited

Central Commercial Park
Centre Park Road
Cork
Ireland

Tel: 00 353 21 4966 311 Fax: 00 353 21 4965 273
e-mail: marketing@freefoam.com
website: www.freefoam.com

| | |
|------|----|
| (41) | n7 |
|------|----|

**Agrément
Certificate
No 99/3585**
Second issue*

Designated by Government
to issue
European Technical
Approvals

FREEFOAM WHITE PVC-U ROOF TRIM SYSTEM

Accessoires en PVC-U pour toits
Zubehör (von PVC-U) für Dächer

Product



• THIS CERTIFICATE OF CONFIRMATION RELATES TO THE FREEFOAM WHITE PVC-U ROOF TRIM SYSTEM, COMPRISING FASCIA, SOFFIT AND BARGE BOARDS, SOFFIT VENTILATOR, AND ACCESSORIES.

• The system is for external use on roofs as a substitute for timber or other conventional materials.

• It is essential that the system is installed in accordance with the manufacturer's instructions and the Design Data and Installation parts of this Certificate.

This Certificate is a confirmation of Irish Agrément Certificate No 95/0062 issued by the IAB.

Regulations

1 The Building Regulations 2000 (as amended) (England and Wales)



The Secretary of State has agreed with the British Board of Agrément the requirements of the Building Regulations to which roofline systems can contribute in achieving compliance. In the opinion of the BBA, the Freefoam White PVC-U Roof Trim System, if used in accordance with the provisions of this Certificate, will meet or contribute to meeting the relevant requirements.

Requirement: C2(b)

Resistance to moisture

Comment:

The system will contribute to providing protection against the penetration of moisture to the inner surface of the building on which it is installed. See section 7.1 of this Certificate.

Requirement: C2(c)

Resistance to moisture

Comment:

When used in accordance with this Certificate, the soffit ventilators can contribute to enabling a roof to meet this Requirement. See sections 7.4 to 7.13 of this Certificate.

Requirement: Regulation 7

Materials and workmanship

Comment:

The components of the system are acceptable. See section 12.1 of this Certificate.

Electronic Copy

2 The Building (Scotland) Regulations 2004



In the opinion of the BBA, the Freefoam White PVC-U Roof Trim System, if used in accordance with the provisions of this Certificate, will satisfy or contribute to satisfying the various Regulations and related Mandatory Standards as listed below.

| | | |
|-------------|------|--|
| Regulation: | 8 | Fitness and durability of materials and workmanship |
| Regulation: | 8(1) | Fitness and durability of materials and workmanship |
| Comment: | | The system can contribute to a construction satisfying this Regulation. See section 12.1 and the <i>Installation</i> part of this Certificate |
| Regulation: | 9 | Building standards – construction |
| Standard: | 3.10 | Precipitation |
| Comment: | | The system will contribute to satisfying this Standard, with reference to clause 3.10.1 ⁽¹⁾⁽²⁾ by giving protection against the penetration of moisture to the inner surface of the building on which it is installed. See section 7.1 of this Certificate. |
| Standard: | 3.15 | Condensation |
| Comment: | | The soffit ventilators can contribute towards enabling a roof to meet this Standard, with reference to clauses 3.15.1 ⁽¹⁾ and 3.15.4 ⁽¹⁾ . See sections 7.4 to 7.13 of this Certificate. (1) Technical Handbook (Domestic). (2) Technical Handbook (Non-Domestic). |

3 The Building Regulations (Northern Ireland) 2000



In the opinion of the BBA, the Freefoam White PVC-U Roof Trim System, if used in accordance with the provisions of this Certificate, will satisfy or contribute to satisfying the various Building Regulations as listed below.

| | | |
|-------------|----|--|
| Regulation: | B2 | Fitness of materials and workmanship |
| Comment: | | The components of the system are acceptable. See section 12.1 of this Certificate. |
| Regulation: | C4 | Resistance to ground moisture and weather |
| Comment: | | The system will contribute to providing protection against the penetration of moisture to the inner surface of the building on which it is installed. See section 7.1 of this Certificate. |
| Regulation: | C5 | Condensation |
| Comment: | | The soffit ventilators can contribute towards enabling a roof to meet this Regulation. See sections 7.4 to 7.13 of this Certificate. |

4 Construction (Design and Management) Regulations 1994 (as amended)

Construction (Design and Management) Regulations (Northern Ireland) 1995 (as amended)

Information in this Certificate may assist the client, planning supervisor, designer and contractors to address their obligations under these Regulations.

See sections: 8 *Practicability of installation* and 13 *General* (13.3).

Technical Specification

5 Description

5.1 The Freefoam White PVC-U Roof Trim System is for external use at the roofline as a substitute for timber or other conventional materials.

5.2 The system comprises a range of cellular PVC-U (PVC-UE) boards (see Figure 1), ancillary components including a rigid soffit ventilator, rigid hollow soffits and other extruded trims, and injection moulded joints and end caps (see Figure 2).

5.3 The soffit ventilator provides a means of ventilating the roof void.

5.4 The cellular boards comprise a closed-cell cellular PVC-U core beneath an outer weathering, impact-modified, glossy PVC-U skin. The soffit ventilator, rigid hollow soffits and other extruded trims are composed of impact-modified PVC-U and the injection mouldings of PVC-U.

5.5 Characteristics of the cellular boards are shown in Table 1.

5.6 The cellular boards are manufactured by co-extruding a high-impact PVC-U compound onto a foamable PVC-U compound, cooling and forming to section. Cellular PVC-U is formed during the process by the evolution of gas from sodium bicarbonate present in the foamable PVC-U compound.

Table 1 Characteristics of boards

| | Plain fascia FW | Ogee fascia FO | Magnum fascia FMS | Soffit board GPB | Magnum Xtra FMXS | Magnum round nose FMR | Magnum Duo FMD | Magnum ogee FMO |
|---|--------------------|-------------------|----------------------|---------------------|---------------------|--------------------------|-------------------|--------------------|
| Standard length (m) | 5 | 5 | 5 | 5 | 5 | 5 | 5 | 5 |
| Nominal thickness (mm) | 10 | 10 | 18 | 10 | 25 | 18 | 15 | 18 |
| Minimum thickness of outer skin (mm) | 0.5 | 0.5 | 0.5 | 0.5 | 0.5 | 0.5 | 0.5 | 0.5 |
| Average density (kgm ⁻³) | 0.48 | 0.48 | 0.48 | 0.48 | 0.48 | 0.48 | 0.48 | 0.48 |

Figure 1 Cellular boards (all dimensions in mm)

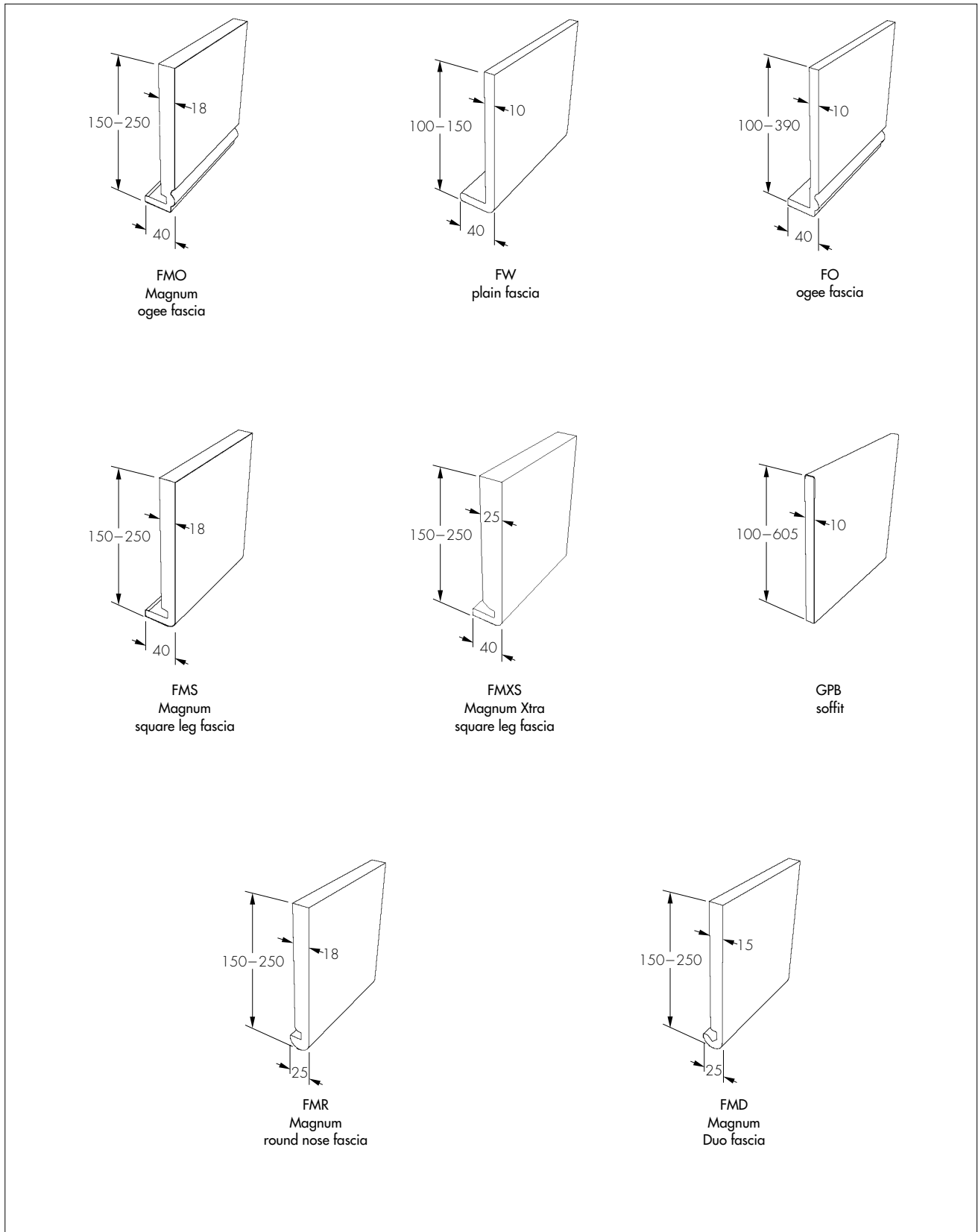
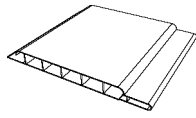
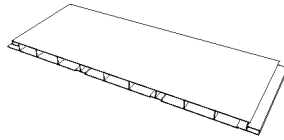

Figure 2 Ancillary components

rigid hollow soffits



F104



F110

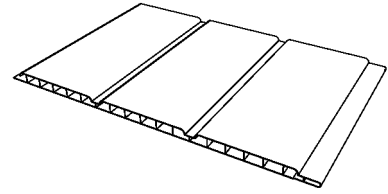

F112

fascia corners and joiners

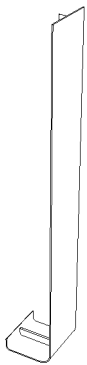

FWJ⁽¹⁾
plain
fascia
joiner

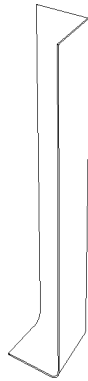

FWX⁽¹⁾
plain
fascia
corner



FOJ⁽²⁾
ogee
fascia
joiner

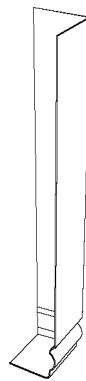

FOX⁽²⁾
ogee
fascia
corner

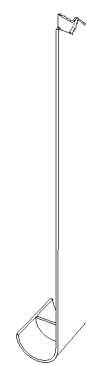

FMRJJ⁽³⁾
Magnum fascia
double-ended
round nose
joiner

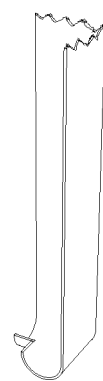

FMRXX⁽³⁾
Magnum fascia
double-ended
round nose
corner

soffit trims

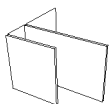

F105
'F' trim

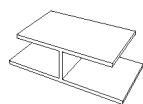

F106
centre joint trim

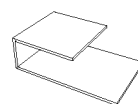

F107
'U'/starter trim

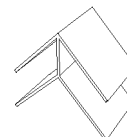

F108
external corner trim

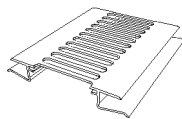

F109
soffit ventilator

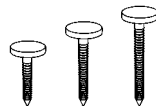

N40/N50/N60
plastop nails

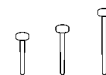

P25/P30/P40
plastop pins

(1) FWJ and FWX items are used with FMS (Magnum square leg fascia) and FMXS (Magnum Xtra square leg fascia).

(2) FOJ and FOX items are used with FO (ogee fascia) and FMO (Magnum ogee fascia).

(3) FURJ and FMRXX items are only available double-ended and are used with FMD (Magnum Duo fascia) and FMR (Magnum round nose fascia).

Electronic Copy

5.7 The ancillary components are manufactured using conventional extrusion and injection moulding techniques.

5.8 Continuous quality control is undertaken during manufacture. Checks include:

- appearance
- colour
- dimensions
- weight per metre
- impact strength
- heat reversion
- heat ageing.

5.9 Stainless steel, annular ring-shank nails with white plastic heads are available from the manufacturer for fixing cellular boards and ancillary components. 40 mm, 50 mm and 65 mm long, 3 mm shank diameter, 12 mm head diameter nails are recommended for fascia boards and 25 mm, 30 mm and 40 mm long, 2 mm shank diameter, 7 mm head diameter nails for other components. Secret fix, stainless steel cladding pins (30 mm long) are available for fixing soffit trims.

6 Delivery and site handling

6.1 The boards are delivered in packs sealed in polythene sleeves. Pack quantities vary dependent upon the type of profile.

6.2 The packs should be unloaded by hand to avoid damage, stored flat in the polythene sleeves on a clean, level surface in stacks not exceeding one metre in height and restrained from collapse. To avoid damage it is recommended that additional protection is provided when the planks are stored in the open.

Design Data

7 General



7.1 The Freefoam White PVC-U Roof Trim System is suitable for use externally to provide a protective and decorative trim at the roofline where timber or other conventional materials would normally be used.

7.2 The system must be fixed only to structurally sound building substrates, at centres not exceeding 600 mm. Rafter feet and gable ladders should be adequately supported by noggings to ensure rigidity. Replacement, rather than over fixing, of existing fascia, is recommended. Timber roof structures, to which the system is fixed, must be designed and/or constructed in accordance with the relevant Building Regulations and, as appropriate, in compliance with one of the following technical specifications:

- BS 5268-2 : 2002
- BS 5268-3 : 1998

- The Building Regulations 2000 (as amended) (England and Wales), Approved Document A1/2, Section 2A
- The Building Regulations (Northern Ireland) 2000, Part D *Structure*.

7.3 The cellular PVC-U components have a similar coefficient of thermal expansion to that of conventional solid PVC-U. A 5 mm gap should be provided at the end of each board (ie 10 mm between boards), to allow for movement. Care should be taken not to install the system in extremes of temperature. The recommended temperature for installation is between 5°C and 25°C.

Ventilation



7.4 The Freefoam soffit ventilator can contribute towards providing the necessary roof space ventilation. Guidance on the provision of adequate ventilation is given in the 2004 edition of the Approved Document C2 *Resistance to moisture* to the Building Regulations 2000 (as amended) (England and Wales) and in BS 5250 : 2002, Clause 8.4.

7.5 When providing roof space ventilation it is essential that the airway should not be allowed to become blocked by the loft insulation. This may be achieved by the use of a suitable BBA approved insulation retainer producing an air passage with an effective area (geometric free area) at least equal to that of the soffit ventilator used.

7.6 The soffit ventilator trim (without mesh) has a vented area of 25 298 mm² per metre run (equivalent to a continuous slot 25.3 mm wide at eaves level) and is suitable for the applications given in sections 7.7 to 7.9.

7.7 For roofs with a pitch of 15° or more, where both the ceiling and insulation are horizontal, soffit ventilators with a minimum vented area of 10 000 mm² per metre run, if used in accordance with section 7.5, can provide adequate ventilation to insulated loft spaces as set out in BS 5250 : 2002, Clause 8.4. The soffit ventilators should run along the eaves of the longest opposite sides of a rectangular roof to provide adequate cross-ventilation. The ventilators are suitable for use with traditional (semi-permeable) and high performance (impermeable) sarking felts. Consideration should be given to the use of high-level ventilation openings to increase the ventilation rate for roofs as recommended in BS 5250 : 2002, Clause 8.4. The use of high-level ventilation openings is strongly recommended in roofs with a pitch greater than 35° or roof spans in excess of 10 metres.

7.8 For roofs where the ceiling follows the pitch of the roof, soffit ventilators with a minimum vented area of 25 000 mm² per metre run, if used in conjunction with suitable high-level ventilation, can provide adequately for roof voids as set out in BS 5250 : 2002, Clause 8.4. It is essential that a

minimum unrestricted air space of 50 mm is maintained between the underside of the roof deck and the top of the insulation. Consideration should be given to the probability of the sarking felt bowing between rafters and it should be ensured that this does not reduce the gap between felt and insulation to less than 50 mm. Where there is an obstruction to the ventilation, eg rooflights or a change in pitch of roof, adequate ventilation, in accordance with the requirements of BS 5250 : 2002, Clause 8.4, should be provided above and below the obstruction using suitable ventilators. The required ventilation at high level and around obstructions may be achieved by using a suitable BBA approved ventilator.

7.9 For roofs with a pitch of less than 15°, soffit ventilators with a minimum vented area of 25000 mm² per metre run, if used in accordance with section 7.5, can provide adequate ventilation to insulated roof voids as set out in BS 5250 : 2002, Clause 8.4. When providing roof space ventilation for flat roofs, it is essential that a minimum unrestricted air space of 50 mm is maintained between the underside of the roof deck and the top of the insulation. Ventilation should be provided along two opposite sides of the deck: where possible these should be the two longest sides to achieve maximum cross-ventilation. The recommendations contained in BS 5250 : 2002, Clause 8.4, should be followed when planning the provision of ventilation to flat roofs, especially where spans exceed 5 metres, or for concrete deck roofs. Where a flat roof has a span of greater than 10 metres, or is not of a simple rectangular plan, more ventilation will be required, totalling at least 0.6% of the total area of the roof. It should be noted that cold, flat roof construction is generally unacceptable in Scotland and not the preferred option elsewhere in the UK⁽¹⁾.

(1) See BRE report (BR : 262) 2002 *Thermal insulation : avoiding risks*.

7.10 Where soffit ventilators are used in lean-to or mono-pitched roofs, high-level ventilation, in accordance with BS 5250 : 2002, Clause 8.4, must be provided.

7.11 Where a pitched roof abuts a wall, additional high-level ventilation must be arranged to provide an open area at least equal to a 5 mm slot running the full length of the abutment.

7.12 The soffit ventilator sections meet NHBC requirements for protection against the ingress of birds, rodents or large insects. A mesh incorporated into the ventilator, permissible in applications covered by section 7.7, will increase this protection.

7.13 The dimensions of the slots in the soffit ventilator are such that the risk of blockage is limited. However, the slots should be examined occasionally and cleared if necessary.

8 Practicability of installation

Special training is not required to install the roof trim system correctly, provided the manufacturer's instructions and the procedures outlined in section 14 of this Certificate are followed. However, normal precautions should be taken when installing boards at roof level.

9 Strength and stability

9.1 When installed in accordance with this Certificate, the system will withstand, without damage or permanent deflection, the wind loads likely to be encountered in the United Kingdom. In exposed locations care should be taken to ensure that all profiles are adequately fixed.

9.2 The system has adequate resistance to the hard and soft body impacts likely to occur in practice.

9.3 PVC-U gutters, as specified in BS 4576-1 : 1989, may be screw-fixed directly to the Magnum boards. Gutter bracket spacing must not exceed one metre; reduced spacings are recommended in the Scottish Highlands. Other lightweight gutters may also be screw-fixed to the Magnum board provided the maximum bracket loading, covered in BS 4576-1 : 1989, is not exceeded. For other boards, all gutters should be fixed through the fascia to rafter ends of other sound timber.

9.4 Magnum boards will support all eaves tiles in common usage in the UK (up to 10 kg load per 1 m length of fascia), provided they are installed in accordance with the requirements of this Certificate.

9.5 Apart from the exception detailed in section 9.4, the fascia boards are not loadbearing and must not be used independently to support fixtures such as roof tiles, gutters, other roof structure components, or television aerials. Suitably fixed telephone wires and power cables may be run along the boards, but the main brackets for these services should be fixed through the fascia to structurally sound timber.

10 Performance in relation to fire

10.1 When tested in accordance with BS 476-7 : 1997 the cellular boards achieved a Class 1Y surface spread of flame rating and rigid hollow soffit boards achieved a surface spread of flame rating of Class 2Y.

10.2 On exposure to fire, PVC-U tends to char and may fall away. The spread of flame along its surface is limited. It is unlikely that the roof trim system will significantly affect the overall fire performance of any roof in which it is installed.

10.3 Where it is normal practice to carry the eaves box over, between dwellings, it is important that the box is fire-stopped at compartment walls.

11 Maintenance

11.1 The system can be cleaned by washing with water and detergent. Solvent-based cleaners should not be used. The material can be cut and drilled, using normal woodworking tools, if repairs are required.

11.2 As with all PVC products, paint can adversely affect the impact strength of the cellular PVC-U sections, and the application of dark colours could lead to a risk of thermal distortion. Therefore, painting is not recommended.

12 Durability

 12.1 Accelerated weathering tests indicate that Freefoam cellular PVC-U is as durable as conventional solid PVC-U and that profiles will retain adequate impact resistance for a period in excess of 20 years.

12.2 The system will retain its decorative qualities for a period in excess of 20 years with only minor changes in surface appearance.

12.3 Where the timber substrate is preservative treated with copper/chrome/arsenic⁽¹⁾ or copper/chrome/boron, care must be taken to ensure that sufficient time is allowed for complete fixation of the preservative (approximately seven days) to avoid corrosion of screws and nails used to fix the components.

(1) CCA products should not be used in domestic applications according to European Union restrictions.

Installation

13 General

13.1 Installation of the Freefoam White PVC-U Roof Trim System must be carried out in accordance with the manufacturer's instructions and the requirements of this Certificate.

13.2 The components of the system are easy to work using normal woodworking tools for cutting, drilling and shaping. Handsaws should have a fine-toothed blade. Hand-held and bench-mounted power tools with a carbide-tipped blade should be run at speeds similar to, or higher than, those normally used for timber (see also section 8.2).

13.3 When using power tools to cut or shape the product, it is recommended that eye protection and a coarse-particle dust mask are used.

13.4 Fascia, soffit and barge boards should be fixed to preservative-treated, structurally sound timber at centres not exceeding 600 mm, using the nails or pins specified by the manufacturer. Rotten timber must be replaced by new treated timber.

13.5 Sarking felt should be checked to ensure that it is in good condition and extends onto the verge rafter and over a continuous tilting fillet and fascia

into the gutter at the eaves. Damaged or worn felt should be replaced.

13.6 For the Magnum board, gutter brackets may be fixed directly into the board at spacings not greater than one metre, using the screws recommended by the manufacturer. The screws should penetrate the rear face of the board. For all other boards, gutter brackets are screwed through the fascia board into rafter feet or other timber support (see section 9.3).

13.7 Soffit ventilators should be installed so that the roof ventilation conforms to the relevant Building Regulations.

14 Procedure

14.1 Selected boards and accessories are assembled and cut to size.

14.2 Rafter feet are cut to a line.

14.3 Noggings, soffit bearers, battens, eaves fillets, brackets and other additional timber supports are fixed to a sound substrate.

14.4 Protective films should be removed just prior to fixing, ie peeled off as nailing progresses along the board.

14.5 The summary for the installation details of fascia, soffit and barge boards (see sections 14.6 to 14.16) should be read with reference to the typical installation diagrams shown in Figure 3.

Fascias

14.6 Fascia boards are fixed to rafter feet at centres not exceeding 600 mm, using two specified ring-shanked nails. Magnum boards may be fixed directly to rafter feet using 65 mm long nails. For other boards it is normal practice to fix⁽¹⁾ to the rafter feet through a 25 mm thick, marine plywood backing board or equivalent previously fixed to the rafter timbers.

(1) Using nails at least 40 mm long.

14.7 Butt joints between fascia boards should be made at the rafter with a 10 mm wide expansion gap between and with both boards fixed to the rafter foot. A joiner trim is fixed to one board only with a specified 25 mm or 30 mm long nail or a suitable low-modulus silicone sealant.

14.8 At corners both boards are fixed to sound timber, allowing a 5 mm expansion gap at the end of each board. A corner trim is fixed to the end of one board as described in section 14.7.

Soffits

14.9 Soffits are made from cellular soffit boards or rigid hollow soffits. The latter may be used lengthways or in short lengths at right angles to the wall. To give a tongue-and-groove effect, the indented face should be exposed.

Electronic Copy

14.10 The soffit should fit into or onto the fascia and into a trim or onto a nogging on the wall.

14.11 The boards are fixed to rafter feet, soffit bearers, or other timber support at centres along their length, not exceeding 600 mm, and across their width, not exceeding 150 mm, using the specified 30 mm nails.

14.12 Where required, soffit boards may be joined along their length or width using a joint trim.

14.13 To comply with building regulations a ventilator trim is incorporated into the soffit, as necessary.

Barge boards

14.14 Barge boards are installed by fixing fascia boards to a gable ladder or noggings, using the procedures given in sections 14.6 and 14.7.

14.15 Barge boards meeting at a ridge should be mitred to the appropriate angle.

14.16 Box ends are constructed from fascia board and trims to suit the roof pitch and overhead requirement. Any timber framework required in the construction of the box end must be preservative treated.

Figure 3 Typical installation details

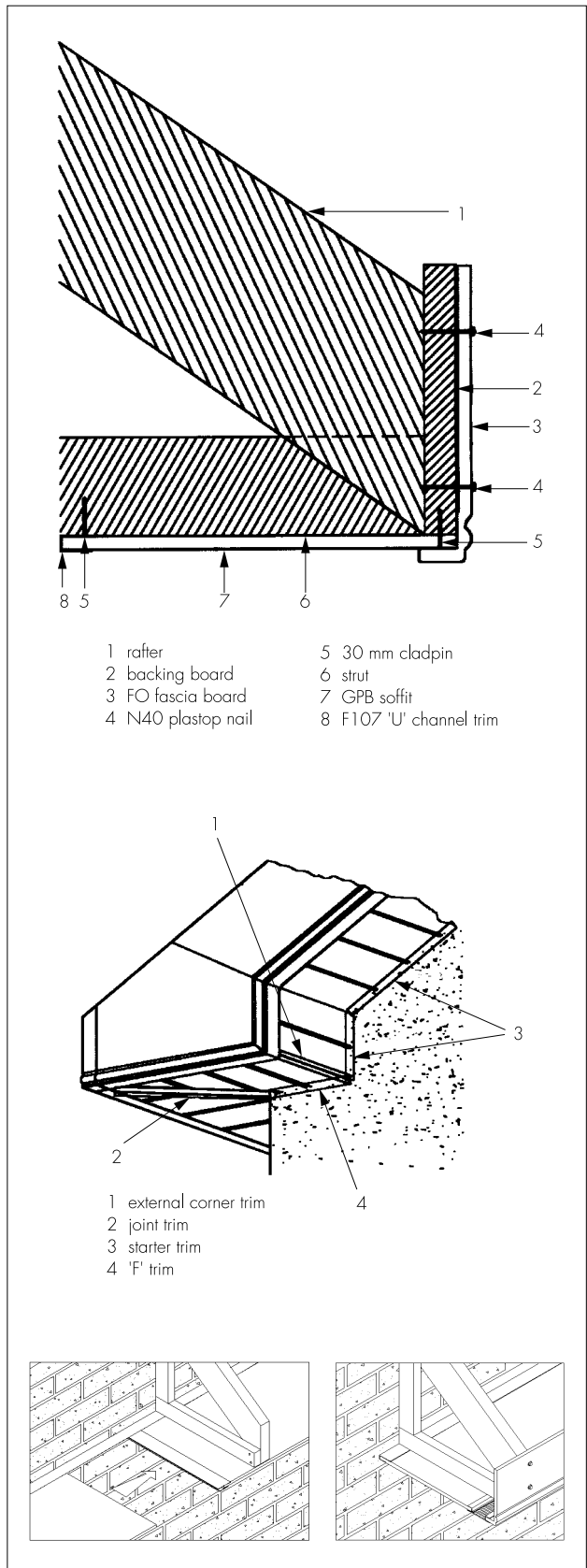

Technical Investigations

The following is a summary of the technical investigations carried out on the Freefoam White PVC-U Roof Trim System.

15 Tests

Tests were carried out to determine:

weight per linear metre

- density
- ash content
- impact strength
- dimensional stability
- resistance to impact after UV ageing
- resistance to impact at low temperature
- accelerated weathering
- natural weathering
- nail pull-through
- water absorption
- heat reversion
- resistance to acetone
- Vicat softening temperature
- flexural strength and modulus of elasticity
- resistance to heat ageing
- resistance to tile and gutter loading.

16 Investigations

16.1 Following the determination of nail pull-through values, calculations were undertaken to establish the resistance of the product to wind suction.

16.2 The dimensions of cellular boards and trims were checked.

16.3 An assessment was made of the acceptability of the soffit ventilator in meeting ventilation requirements.

16.4 An examination was made of existing data relating to:

- surface spread of flame
- colour stability.

16.5 The manufacturing process, including the methods adopted for quality control, were examined and details were obtained of the quality and composition of the materials used.

16.6 The practicability of the installation was assessed.

Bibliography

BS 476-7 : 1997 *Fire tests on building materials and structures — Method of test to determine the classification of the surface spread of flame of products*

BS 4576-1 : 1989 *Specification for unplasticized polyvinyl chloride (PVC-U) rainwater goods and accessories*

BS 5250 : 2002 *Code of practice for control of condensation in buildings*

BS 5268-2 : 2002 *Structural use of timber — Code of practice for permissible stress design, materials and workmanship*

BS 5268-3 : 1998 *Structural use of timber — Code of practice for trussed rafter roofs*

Conditions of Certification

17 Conditions

17.1 This Certificate:

- relates only to the product/system that is named and described on the front page
- is granted only to the company, firm or person named on the front page — no other company, firm or person may hold or claim any entitlement to this Certificate
- is valid only within the UK
- has to be read, considered and used as a whole document — it may be misleading and will be incomplete to be selective
- is copyright of the BBA
- is subject to English law.

17.2 References in this Certificate to any Act of Parliament, Regulation made thereunder, Directive or Regulation of the European Union, Statutory Instrument, Code of Practice, British Standard, manufacturers' instructions or similar publication, are references to such publication in the form in which it was current at the date of this Certificate.

17.3 This Certificate will remain valid for an unlimited period provided that the product/system and the manufacture and/or fabrication including all related and relevant processes thereof:

- are maintained at or above the levels which have been assessed and found to be satisfactory by the BBA
- remain covered by a valid Irish Agrément; and
- are reviewed by the BBA as and when it considers appropriate.

17.4 In granting this Certificate, the BBA is not responsible for:

- the presence or absence of any patent, intellectual property or similar rights subsisting in the product/system or any other product/system
- the right of the Certificate holder to manufacture, supply, install, maintain or market the product/system
- individual installations of the product or system, including the nature, design, methods and workmanship of or related to the installation
- the actual works in which the product/system is installed, used and maintained, including the nature, design, methods and workmanship of such works.

17.5 Any information relating to the manufacture, supply, installation, use and maintenance of this product/system which is contained or referred to in this Certificate is the minimum required to be met when the product/system is manufactured, supplied, installed, used and maintained. It does not purport in any way to restate the requirements of the Health & Safety at Work etc Act 1974, or of any other statutory, common law or other duty which may exist at the date of this Certificate or in the future; nor is conformity with such information to be taken as satisfying the requirements of the 1974 Act or of any present or future statutory, common law or other duty of care. In granting this Certificate, the BBA does not accept responsibility to any person or body for any loss or damage, including personal injury, arising as a direct or indirect result of the manufacture, supply, installation, use and maintenance of this product/system.



In the opinion of the British Board of Agrément, the Freefoam White PVC-U Roof Trim System is fit for its intended use provided it is installed, used and maintained as set out in this Certificate. Certificate No 99/3585 is accordingly awarded to Freefoam Plastics Limited.

On behalf of the British Board of Agrément

Date of Second issue: 27th November 2006

Chief Executive

**Original Certificate issued on 8th March 1999. This amended version includes reference to revised Building Regulations, additional fascia boards and associated trims, a revised Bibliography and new Conditions of Certification.*

Electronic Copy

British Board of Agrément

P O Box No 195, Bucknalls Lane
Garston, Watford, Herts WD25 9BA
Fax: 01923 665301

©2006

e-mail: mail@bba.star.co.uk
website: www.bbacerts.co.uk



For technical or additional information,
contact the Certificate holder (see
front page).
For information about the Agrément
Certificate, including validity and
scope, tel: Hotline 01923 665400,
or check the BBA website.