

## Link Middle East Ltd

P O Box 16846  
Jebel Ali  
Dubai  
United Arab Emirates  
Tel: 00 971 4 8816750 Fax: 00 971 4 8816250  
e-mail: lmedubai@emirates.net.ae  
website: lmewireproducts.com



Agrément Certificate  
**00/3682**  
Product Sheet 1

### LINK MIDDLE EAST (LME) EARTH RETENTION AND PROTECTION SYSTEMS

### LME WOVEN HEXAGONAL MESH GABION BOXES, MATTRESSES AND SAC GABIONS

#### PRODUCT SCOPE AND SUMMARY OF CERTIFICATE

This Certificate relates to LME Woven Hexagonal Mesh Gabion Boxes, Mattresses and Sac Gabions, containers formed from a woven hexagonal mesh of galvanized or Galvan-coated wire additionally PVC-coated, where required, for use in temporary and long-term earth retention, soil reinforcement, river training and erosion control applications.

#### AGRÉMENT CERTIFICATION INCLUDES:

- factors relating to compliance with Building Regulations where applicable
- factors relating to additional non-regulatory information where applicable
- independently verified technical specification
- assessment criteria and technical investigations
- design considerations
- installation guidance
- regular surveillance of production
- formal three-yearly review.



#### KEY FACTORS ASSESSED

**Structural performance** — the products, when used correctly in a fully designed application, will have adequate strength to resist the anticipated loads (see section 5).

**Durability** — when used in dry, land-retaining applications, the powder-coated mesh may be considered to have a life expectancy of 120 years (see section 7).

The BBA has awarded this Agrément Certificate to the company named above for the products described herein. These products have been assessed by the BBA as being fit for their intended use provided they are installed, used and maintained as set out in this Certificate.

On behalf of the British Board of Agrément

Date of First issue: 12 October 2010

Originally certified on 28 February 2000

Handwritten signature of Brian Chamberlain in black ink.

Brian Chamberlain

Head of Approvals — Engineering

Handwritten signature of Greg Cooper in black ink.

Greg Cooper

Chief Executive

*The BBA is a UKAS accredited certification body — Number 113. The schedule of the current scope of accreditation for product certification is available in pdf format via the UKAS link on the BBA website at [www.bbacerts.co.uk](http://www.bbacerts.co.uk)*

*Readers are advised to check the validity and latest issue number of this Agrément Certificate by either referring to the BBA website or contacting the BBA direct.*

British Board of Agrément  
Bucknalls Lane  
Garston, Watford  
Herts WD25 9BA

©2010

tel: 01923 665300  
fax: 01923 665301  
e-mail: [mail@bba.star.co.uk](mailto:mail@bba.star.co.uk)  
website: [www.bbacerts.co.uk](http://www.bbacerts.co.uk)

## Regulations

In the opinion of the BBA, LME Woven Hexagonal Mesh Gabion Boxes, Mattresses and Sac Gabions, if used in accordance with the provisions of this Certificate, will meet or contribute to meeting the relevant requirements of the following Building Regulations:



### **The Building Regulations 2010 (England and Wales)**

In the opinion of the BBA, LME Woven Hexagonal Mesh Gabion Boxes, Mattresses and Sac Gabions are not subject to these regulations.



### **The Building (Scotland) Regulations 2004 (as amended)**

In the opinion of the BBA, LME Woven Hexagonal Mesh Gabion Boxes, Mattresses and Sac Gabions are not subject to these regulations.



### **The Building Regulations (Northern Ireland) 2000 (as amended)**

In the opinion of the BBA, LME Woven Hexagonal Mesh Gabion Boxes, Mattresses and Sac Gabions are not subject to these regulations.

### **Construction (Design and Management) Regulations 2007**

### **Construction (Design and Management) Regulations (Northern Ireland) 2007**

Information in this Certificate may assist the client, CDM co-ordinator, designer and contractors to address their obligations under these Regulations.

See sections: *2 Delivery and site handling (2.1 and 2.4) and 9 Procedure (9.11 to 9.12 and 9.21) of this Certificate.*

## Non-regulatory Information

### **NHBC Standards 2010**

In the opinion of the BBA, the use of LME Woven Hexagonal Mesh Gabion Boxes, Mattresses and Sac Gabions, in relation to this Certificate, is not subject to the requirements of these Standards.

## General

This Certificate relates to LME Woven Hexagonal Mesh Gabion Boxes, Mattresses and Sac Gabions for use in earth retention, soil reinforcement, river training and erosion control applications.

Construction of the system is usually carried out by civil engineering or building contractors who must ensure that the installation of the system is in accordance with the Certificate holder's instructions and information given in this Certificate.

The gabions are marketed in the UK by Cerana Ltd (trading as Enviromesh), Garner Street Business Park, Etruria, Stoke-on-Trent, Staffordshire ST4 7BH. Tel: 0845 1360101; Fax: 0845 1360202; e-mail: [enquiries@enviromeshsolutions.com](mailto:enquiries@enviromeshsolutions.com); website: [www.enviromeshsolutions.com](http://www.enviromeshsolutions.com).

## Technical Specification

### **1 Description**

1.1 LME Woven Hexagonal Mesh Gabion Boxes, Mattresses and Sac Gabions are cages formed from woven hexagonal galvanized or Galfan-coated wire mesh with or without a PVC-U coating and are available as flat packs, individual flat panels or in rolls.

1.2 The panels are available in a range of standard sizes (see Table 1). Non-standard sizes are available to special order for specific design requirements.

*Table 1 Standard sizes of gabions*

Length (m)	Gabion		Mattress		Sac Gabion	
	Width (m)	Height (m)	Width (m)	Height (mm)	Width (m)	Height (m)
1	1	0.5 or 1			0.4 or 0.65	0.4 or 1.0
1.5	1	0.5 or 1			0.4 or 0.65	0.4 or 1.0
2 <sup>(1)</sup>	1 or 2	0.5 or 1			0.5 or 1.0	0.5 or 1.5
3 <sup>(1)</sup>	1 or 2	0.5 or 1	2 or 3	170, 230 or 300	0.65 or 1.0	1.0 or 2.25
4 <sup>(1)</sup>	1 or 2	0.5 or 1	2 or 3	170, 230 or 300		
5 <sup>(1)</sup>	2	0.5 or 1	2 or 3	170, 230 or 300		
6 <sup>(1)</sup>			2 or 3	170, 230 or 300		

(1) Diaphragms incorporated at 1 m intervals.

1.3 The wire used in the meshes is generally to BS EN 10218-2 : 1997 and BS EN 10223-3 : 1998 with an ultimate tensile strength of between 350 N·mm<sup>-2</sup> and 500 N·mm<sup>-2</sup> and with a minimum elongation at failure of 10% on a gauge length of 250 mm and drawn from rods complying with BS EN 10016-1 : 1995 and BS EN 10016-2 : 1995. The wire is galvanized or Galvan-coated (95% Zn/ 5% Al) in accordance with BS EN 10244-2 : 2009 (Table 2, Class A). The minimum zinc coating thickness for the various diameters is given in BS EN 10244-2 : 2009 (Table 1, Class A). Where necessary, the wire has an additional PVC-U coating (nominal thickness of 0.50 mm) in accordance with BS EN 10245-2 : 2001 applied by extrusion to the galvanized or coated wires prior to weaving (see Table 2).

*Table 2 Details of coatings*

Nominal core wire diameter (mm)	Minimum overall diameter of PVC-coated wire <sup>(1)</sup> (mm)	Tolerance on core diameter (± mm)	Minimum mass of zinc coating (g·m <sup>-2</sup> )
2.0	3.0	0.05	215
2.2	3.2	0.06	230
2.4	3.4	0.06	230
2.7	3.7	0.06	245
3.0	4.0	0.07	255
3.4	4.4	0.07	265
3.9	4.9	0.07	275

(1) Including PVC coating.

1.4 Details of mesh sizes, the wire used for the range of standard mesh/wire combinations and the associated lacing wire required for on-site fabrication are given in Table 3.

*Table 3 Standard mesh and wire sizes*

Mesh size <sup>(1)</sup> X x Y (mm)	Wire diameter <sup>(2)</sup> (mm)					
	Mesh		Selvedge		Lacing	
	Galvanized	PVC	Galvanized	PVC	Galvanized	PVC
60 x 80	2.0	3.0	2.4	3.4	2.2	3.2
60 x 80	2.2	3.2	2.7	3.7	2.4	3.4
60 x 80, 80 x 100	2.4	3.4	3.0	4.0	–	–
60 x 80, 80 x 100, 100 x 120	2.7	3.7	3.4	4.4	–	–
80 x 100, 100 x 120	3.0	4.0	3.9	4.9	–	–
100 x 120	3.4	4.4	4.4	5.4	–	–

(1) See Figure 1.

(2) To BS EN 10218-2 : 1997, tolerance class T1.

1.5 During fabrication, cut ends are mechanically selvedged with a wire of greater diameter than that used for the mesh wires (see Figure 1).

Figure 1 Selvedge detail

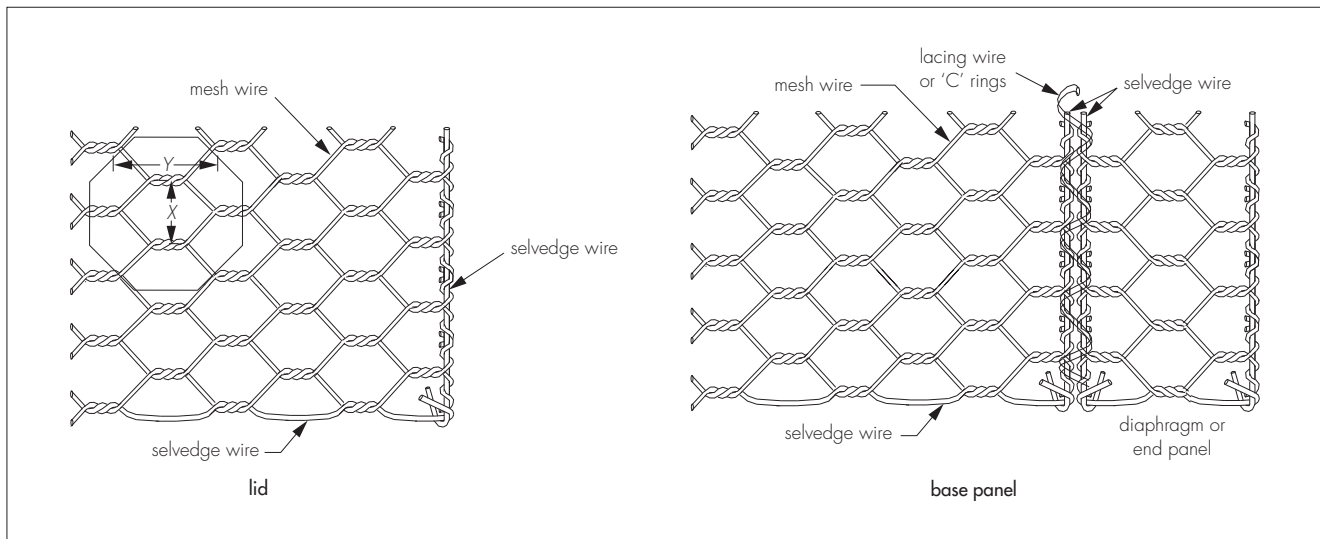

1.6 Box gabion end panels and diaphragms are selvedged along their upper edges in a similar manner to that described in section 1.5.

1.7 Mattresses above 3 m sizes consist of a separate base and a lid. The lid is formed by either a panel of mesh for each base or a roll of mesh used to cover several adjacent mattresses.

1.8 Mattress bases are fabricated from a single panel of mesh having sides formed by folding ends and diaphragms are formed by separate panels laced to base panels during the manufacture (see sections 9.18 to 9.21).

1.9 Steel lifting frames, with the appropriate number of slings/chains attached, are available and must be used to install pre-filled gabions (see section 9.12).

1.10 Quality control is carried out on raw materials, during production process and finished products.

## 2 Delivery and site handling

2.1 Generally, the gabions and mattresses are delivered to site in bales of from one to several bundles, with each bundle consisting of from 1 to 45 gabion boxes weighing up to a maximum of 1000 kg. The bundles of boxes are strapped together to form a bale, which has a maximum height of 2 m and maximum weight of from 2.5 tonnes to 3.5 tonnes.

2.2 The products should be stored in the open, but away from site traffic to avoid the risk of accidental damage, and should remain packaged until required.

2.3 A label bearing the BBA Certificate number, manufacturer's name, batch number and product code is attached to each bundle.

2.4 Bundles must be handled with due care to avoid damage to the coatings. Individual cages can be manhandled.

## Assessment and Technical Investigations

The following is a summary of the assessment and technical investigations carried out on LME Woven Hexagonal Mesh Gabion Boxes, Mattresses and Sac Gabions.

## Design Considerations

### 3 General

#### Gabion boxes

3.1 The design of gabion structures should be based on the principle of mass earth-retaining walls. Additional allowances may be made for the effect of the wire mesh.

3.2 In general, the density of filled gabions should be taken as 60% of the density of the solid material. A higher value may be appropriate in certain circumstances but this will be the responsibility of the consulting engineer who must ensure that the design value is achieved on site.

3.3 The stone infill to the gabions is normally sized between 100 mm and 200 mm and is of hard, durable stone as quarried or naturally occurring rounded stone.

3.4 Gabion walls can be constructed with a minimum radius of curvature of 25 m on plan without modification of the gabion structure.

## **Mattresses**

3.5 The design of the mattress structures should be based on the principles of hydraulic engineering and, where applicable, mass earth-retaining structures.

3.6 The density of filled mattresses should be taken as 60% of the density of the solid material. A higher value may be appropriate in certain circumstances but this will be the responsibility of the consulting engineer, who must ensure that the design value is achieved on site.

3.7 The stone infill to the mattresses is normally sized between 75 mm and 150 mm. The size will depend on the use of the product and the mesh size. In hydraulic structures, the nominal size of the stone should be 1.5 times the mesh size. To ensure adequate protection to the underlying soil, the stone size and grading should be chosen to ensure more than one layer within the mattress depth. The fill must be of hard, durable stone such as quarried or naturally occurring rounded stone.

3.8 Mattresses can be constructed to form curved sections by either cutting and folding units or by overlapping adjacent mattresses.

## **Sac Gabions**

3.9 There are no design standards that relate directly to Sac Gabions. Each structure must be designed by a competent consulting engineer using the principles of mass retaining structures.

## **4 Practicability of installation**

The products are designed to be installed by competent civil engineering or building contractors experienced with these types of products and are installed easily under normal site conditions.

## **5 Structural performance**

5.1 The design of the gabion box and mattress structures should be carried out by a suitably qualified engineer and should be in accordance with BS EN 1997-1 : 2004 and BS 6031 : 2009.

5.2 The magnitude and distribution of the earth pressures and earth resistance should be calculated in accordance with current design philosophy.

5.3 As in other earth-retaining structures, it is necessary to determine a suitable factor of safety against the principal modes of failure for parameters of:

- overall stability
- overturning
- shearing pressure
- sliding
- internal stability.

5.4 Watercourse linings, weirs and other hydraulic structures may require special consideration with regard to scour, uplift, wave action, and seepage.

5.5 The mesh specification should be chosen to achieve the required design life (see section 7).

5.6 If installed in accordance with this Certificate, the mesh has adequate strength to resist the loads associated with handling, positioning and filling.

5.7 Gabions and mattresses are permeable and, in general, will not permit hydrostatic pressure to build up. Gabion earth-retaining structures are not normally designed to withstand hydrostatic pressure.

5.8 Where cohesive materials, eg clay, are retained, water movement may cause it to exude into the gabion structure and block the passage of water. To reduce the risk of a build-up of hydrostatic pressure in these conditions, it may be necessary to provide additional granular layers behind the gabion structure to allow water to drain away.

5.9 Gabions and mattresses have adequate strength to permit pre-filling and placing by crane when designed in accordance with the manufacturer's instructions.

## **6 Maintenance and repair**

Routine maintenance is not normally required. However, damaged exposed mesh can be repaired by securing additional or replacement mesh as required.

## **7 Durability**

7.1 The specification for a particular installation must be chosen to achieve the required design life.

7.2 The life of a gabion structure is dependent on the specification of the mesh wire, the durability of the stone and, in the longer term, the stability of the consolidated mass of the infill material and the conditions of exposure encountered during its design life.

7.3 PVC-U coated, galvanized steel wire will not be affected by the chemicals normally encountered in earth-retaining structures.

7.4 Some local damage may occur to the PVC-U coating during installation and in exposed areas. Evidence from installations indicates that such damage will remain local and will not affect the integrity of the structure. Therefore, when used in dry land retaining walls, the PVC-U coated mesh may be considered to have a life expectancy of 120 years. The Galfan coating has better corrosion prevention than pure galvanizing and may be considered to give an increased design life compared to conventional galvanized wire in the same exposure conditions.

7.5 In severe conditions, including use in sea water, under aggressive conditions, eg polluted environments, or where the anticipated exposure conditions are uncertain, PVC-U-coated mesh should be used to ensure an optimum design life.

7.6 The life expectancy of the non-PVC-U-coated galvanized or Galfan-coated wire products may be estimated from the predicted loss of zinc/zinc aluminium coating based on exposure conditions.

7.7 The life expectancy of products used in river erosion and coastal protection schemes will also be affected by the scouring effects of fast flowing water.

## Installation

### 8 General

Installation of LME Woven Hexagonal Mesh Gabion Boxes, Mattresses and Sac Gabions must be in accordance with this Certificate and the Certificate holder's installation instructions.

### 9 Procedure

**In-situ filled gabion boxes** (see Figures 2 to 6)

9.1 Gabion boxes are opened and folded on a hard surface, pressing out any unwanted creases.

9.2 Front and rear sides, ends and diaphragms are lifted into position to form a box shape.

9.3 Top corners are secured and edges are joined together, using the appropriate lacing wire, starting from the top course in a continuous operation using alternate single and double twists. Alternatively, 'C' rings may be used in every mesh opening.

9.4 A number of empty gabion boxes may be placed in position on a flat surface and secured together as described in section 9.3.

9.5 The gabion boxes are filled with suitable stone such that the mesh lid bears down on the stone to a level approximately 50 mm to 75 mm overfull to allow for settlement of the infill due to self-weight.

9.6 When considered necessary for aesthetic or other considerations, the gabion may be filled whilst under tension. Gabion boxes are tensioned by applying a load, distributed over the full end panel of a row of gabion boxes, to the first cell which has been anchored in position.

9.7 Gabion boxes forming the exposed face of a structure should be filled to one-third height, braced from front to rear, filled to two-thirds height and again braced. Filling may then be completed.

9.8 The mesh lid is folded down, stretched into position and secured to the front, sides and diaphragms.

9.9 It is essential that each gabion box is properly secured to adjacent gabion boxes above, below and on each side, using the lacing wire or 'C' rings as described in section 9.3.

Figure 2 Gabion box folding

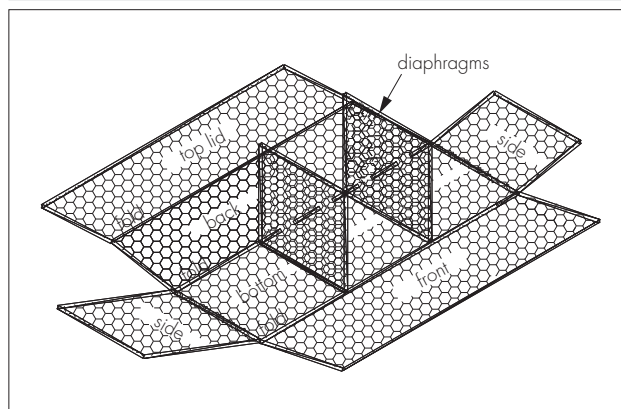

Figure 3 Gabion box panels lacing pattern

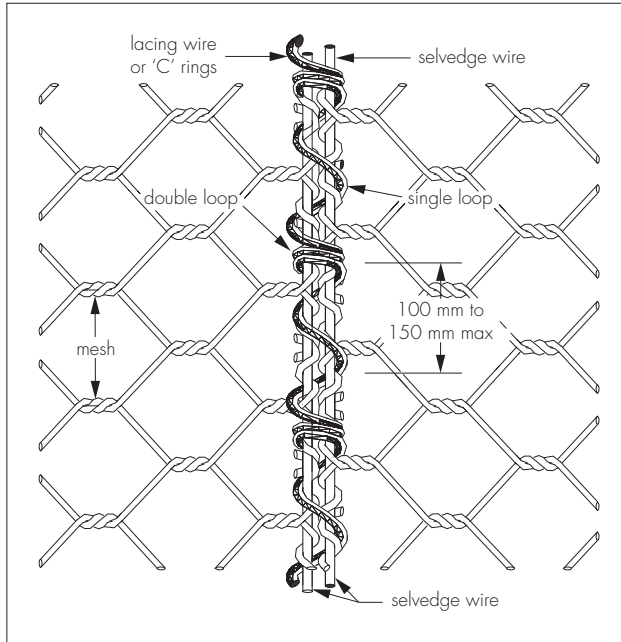

Figure 4 Gabion box forming

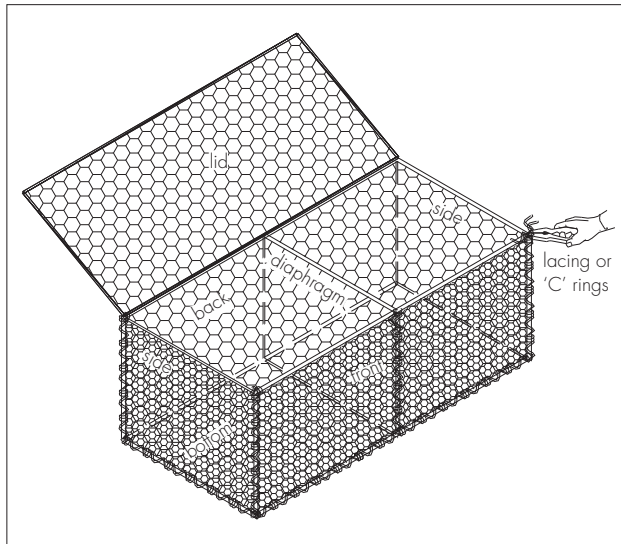

Figure 5 Bracing for gabion boxes

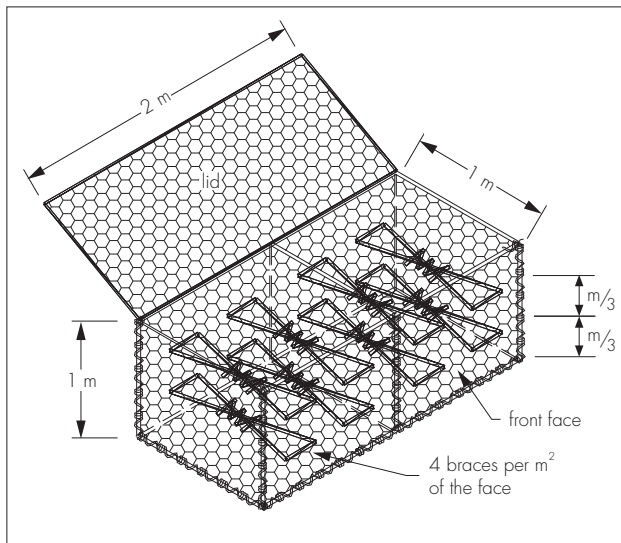
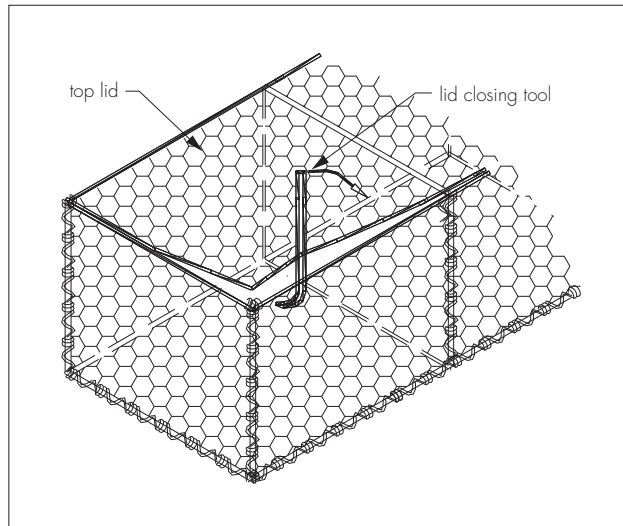

Figure 6 Lid closing for gabion boxes



### Pre-filled gabion boxes

9.10 Gabion boxes are constructed as described in sections 9.1 to 9.3, 9.5, 9.7 and 9.8, but with double loops throughout. However, it is advantageous to construct a slightly oversize frame within which the empty unit can be stretched taut.

9.11 After filling, the horizontal top edges are stiffened, if required, using reinforcing bars, typically 20 mm in diameter, to maintain shape during lifting. Bars should be removed after placement.

9.12 Purpose-made lifting frames and slings must be used for lifting filled units which weigh up to 1.8 tonnes per cubic metre.

### In-situ filled mattresses (see Figures 7 to 9)

9.13 Mattresses are opened and folded on a hard surface, pressing out any unwanted creases.

9.14 Ends, side panels and diaphragms are lifted into position and the ends and diaphragms are secured to the side panels using the method indicated in section 9.3.

9.15 The unit is placed in its final position and secured to adjacent mattresses, ensuring that diaphragms, ends and sides are taut.

9.16 Fill is placed into each compartment, working from the base of the slope upwards, until each cell is filled completely.

9.17 The lid is secured along each edge and diaphragm using lacing wire or 'C' rings as specified.

Figure 7 Preparation of mattresses

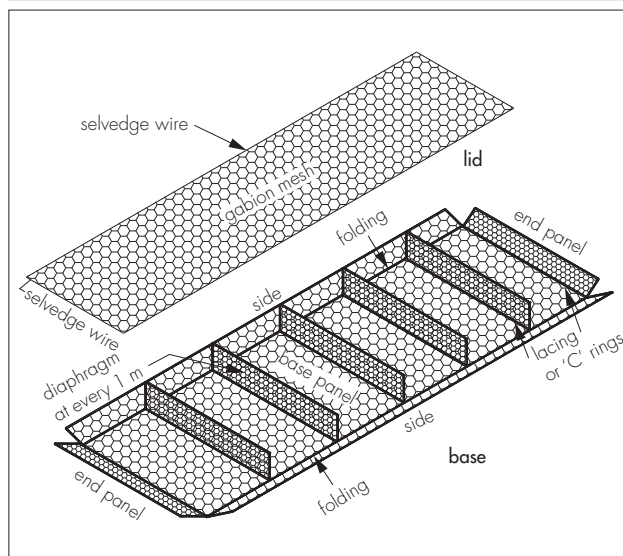

Figure 8 Gabion mattress panels jointing

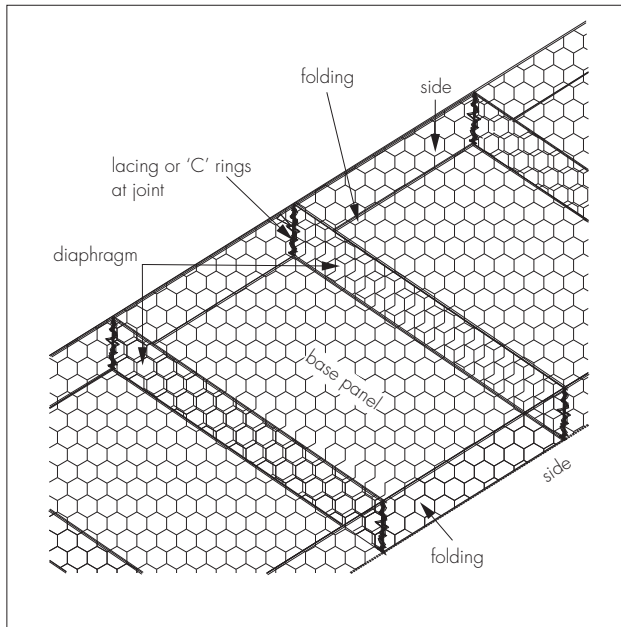
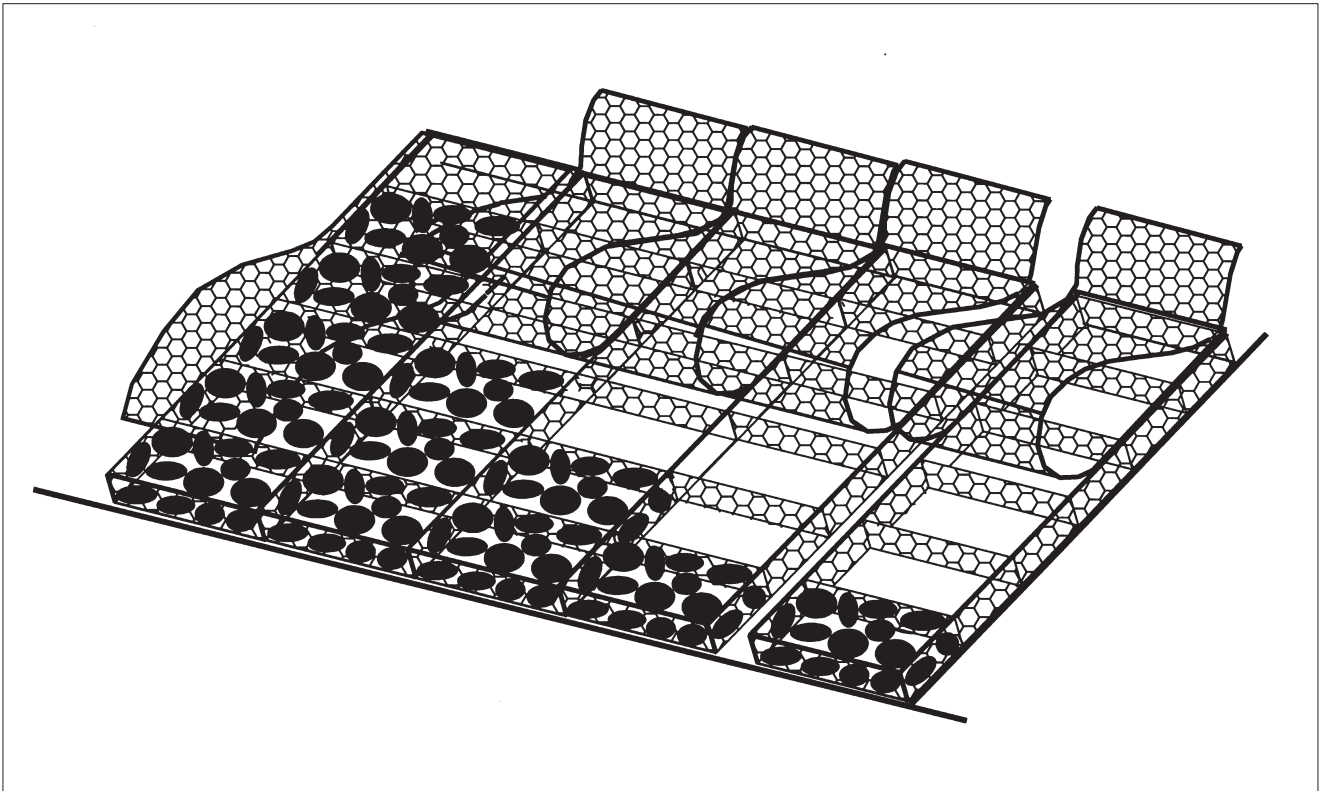

Figure 9 Gabion mattress placing and stone infilling details



**Pre-filled mattresses**

9.18 The mattress is assembled as described in section 9.14, but using double loops throughout or 'C' rings in every opening.

9.19 Additional support should be provided under the lid using steel bars, typically 20 mm in diameter.

9.20 After filling, the unit must be properly secured using the method described in section 9.3.

9.21 Purpose-made lifting frames and slings must be used with suitable attachments to enable the filled mattresses to be safely placed in position.

### 10 Investigations

10.1 The manufacturing process of the gabions and mattresses was examined, including the methods adopted for quality control, and details were obtained of the quality and composition of the materials used.

10.2 An assessment of data was made to determine:

- dimensional accuracy
- quality of galvanized coating
- effect of tolerances
- strength of wire, mesh and filled gabions
- quality of materials
- quality of organic coating
- ease of assembly
- durability
- shearing potential of gabion structures.

10.3 Site visits were carried out to assess the practicability, ease of handling and installation under various site conditions.

## Bibliography

BS 6031 : 2009 *Code of practice for earthworks*

BS EN 1997 : 2004 *Eurocode 7 : Geotechnical design — General rules*

BS EN 10016-1 : 1995 *Non-alloy steel rod for drawing and/or cold rolling — General requirements*

BS EN 10016-2 : 1995 *Non-alloy steel rod for drawing and/or cold rolling — Specific requirements for general purpose rod*

BS EN 10218-2 : 1997 *Steel wire and wire products — General — Wire dimensions and tolerances*

BS EN 10223-3 : 1998 *Steel wire and wire products for fences - Hexagonal steel wire netting for engineering purposes*

BS EN 10244-2 : 2009 *Steel wire and wire products — Non-ferrous metallic coatings on steel wire — Zinc or zinc alloy coatings*

BS EN 10245-2 : 2001 *Steel wire and wire products - Organic coatings on steel wire - PVC finished wire*

## 11 Conditions

11.1 This Certificate:

- relates only to the product/system that is named and described on the front page
- is granted only to the company, firm or person named on the front page — no other company, firm or person may hold or claim any entitlement to this Certificate
- is valid only within the UK
- has to be read, considered and used as a whole document — it may be misleading and will be incomplete to be selective
- is copyright of the BBA
- is subject to English law.

11.2 Publications and documents referred to in this Certificate are those that the BBA deems to be relevant at the date of issue or re-issue of this Certificate and include any: Act of Parliament; Statutory Instrument; Directive; Regulation; British, European or International Standard; Code of Practice; manufacturers' instructions; or any other publication or document similar or related to the aforementioned.

11.3 This Certificate will remain valid for an unlimited period provided that the product/system and the manufacture and/or fabrication including all related and relevant processes thereof:

- are maintained at or above the levels which have been assessed and found to be satisfactory by the BBA
- continue to be checked as and when deemed appropriate by the BBA under arrangements that it will determine
- are reviewed by the BBA as and when it considers appropriate.

11.4 In granting this Certificate, the BBA is not responsible for:

- the presence or absence of any patent, intellectual property or similar rights subsisting in the product/system or any other product/system
- the right of the Certificate holder to manufacture, supply, install, maintain or market the product/system
- individual installations of the product/system, including the nature, design, methods and workmanship of or related to the installation
- the actual works in which the product/system is installed, used and maintained, including the nature, design, methods and workmanship of such works.

11.5 Any information relating to the manufacture, supply, installation, use and maintenance of this product/system which is contained or referred to in this Certificate is the minimum required to be met when the product/system is manufactured, supplied, installed, used and maintained. It does not purport in any way to restate the requirements of the Health & Safety at Work etc Act 1974, or of any other statutory, common law or other duty which may exist at the date of this Certificate; nor is conformity with such information to be taken as satisfying the requirements of the 1974 Act or of any statutory, common law or other duty of care. In granting this Certificate, the BBA does not accept responsibility to any person or body for any loss or damage, including personal injury, arising as a direct or indirect result of the manufacture, supply, installation, use and maintenance of this product/system.

