



SIP Building Systems Ltd

Unit 2, Express Way Industrial Estate
Turnall Road
Ditton
Widnes
Cheshire WA8 8RB

Tel: 0870 224 8040 Fax: 0870 224 8041
e-mail: sales@sipbuildingsystems.co.uk
website: www.sipbuildingsystems.co.uk

CI/SfB

81	Rj7
----	-----

**Agrément
Certificate
No 06/4312**

Second issue*

Amendment 7th August 2008**

Designated by Government
to issue
European Technical
Approvals

SIP BUILDING SYSTEM — SIP LOADBEARING WALL AND ROOF PANELS

Système pour constructions
Bausystem

Product



• THIS CERTIFICATE RELATES TO SIP BUILDING SYSTEM — SIP LOADBEARING WALL AND ROOF PANELS, A SYSTEM OF CONSTRUCTION USING STRUCTURAL INSULATED PANELS MANUFACTURED FROM OSB/3 AND RIGID POLYURETHANE INSULATION.

• The panels are for use above the damp-proof course in domestic application up to two storeys high (plus room-in-roof) as the loadbearing inner leaf of an external cavity wall.

• The panels may also be used as part of a separating wall and internal loadbearing walls.

continued

Regulations

1 The Building Regulations 2000 (as amended) (England and Wales)



The Secretary of State has agreed with the British Board of Agrément the aspects of performance to be used by the BBA in assessing the compliance of building systems with the Building Regulations. In the opinion of the BBA, buildings constructed using SIP Building System – SIP Loadbearing Wall and Roof Panels, if used in accordance with the provisions of this Certificate, will meet or contribute to meeting the relevant requirements.

Requirement: **A1**

Comment:

Loading

Walls and roofs constructed from the panels will have sufficient strength and stiffness when designed in accordance with sections 9.1 and 9.2 of this Certificate.

Requirement: **B3(1)(2)**

Comment:

Internal fire spread (structure)

The panels, with appropriate lining, can be used in walls required to have a fire resistance in excess of 60 minutes. See sections 13.1 and 13.2 of this Certificate.

Requirement: **C2(c)**

Comment:

Resistance to moisture

The panels can adequately limit the risk of surface condensation and will contribute to minimising the risk of interstitial condensation. See sections 10.1 and 10.2 of this Certificate.

Requirement: **E1**

Comment:

Protection against sound from other parts of the building and adjoining buildings
When installed with suitable flanking elements, separating walls incorporating the panels can meet this Requirement. See sections 15.1 to 15.3 of this Certificate.

continued

- It is essential that the system is designed in accordance with the Certificate holder's recommendations and all constructions incorporating the system assessed and approved by a chartered engineer.
- Installation must be carried out by approved contractors.

Requirement:	E2(a)	Protection against sound within a dwelling-house etc
Comment:		A single-leaf, non-loadbearing partition, incorporating suitable plasterboard linings, can meet this Requirement. See section 15.2 of this Certificate.
Requirement:	L1(a)(i)	Conservation of fuel and power
Comment:		See sections 11.4, 11.5, 12.1 and 12.2 of this Certificate.
Requirement:	Regulation 7	Materials and workmanship
Comment:		The panels are acceptable. See section 17.1 of this Certificate.

2 The Building (Scotland) Regulations 2004 (as amended)

 In the opinion of the BBA, SIP Building System – SIP Loadbearing Wall and Roof Panels, if used in accordance with the provisions of this Certificate, will satisfy or contribute to satisfying the various Regulations and related Mandatory Standards as listed below.

Regulation:	8	Fitness and durability of materials and workmanship
Regulation:	8(1)	Fitness and durability of materials and workmanship
Comment:		The panels can contribute to a construction meeting this Regulation. See section 17.1 and the <i>Installation</i> part of this Certificate.
Regulation:	9	Building standards – construction
Standard:	1.1(a)	Structure
Comment:		Walls and roofs incorporating the system panels will have sufficient strength and stiffness when designed and constructed in accordance with sections 9.1 and 9.2 of this Certificate, with reference to clauses 1.1.1 ⁽¹⁾ and 1.1.2 ⁽¹⁾ of this Standard.
Standard:	2.2	Separation
Comment:		Walls using the appropriate lining, can achieve a period of fire resistance of 'medium' duration, with reference to clauses 2.2.1 ⁽¹⁾ to 2.2.3 ⁽¹⁾ of this Standard. See sections 13.4 and 13.5 of this Certificate.
Standard:	2.3	Structural protection
Comment:		Walls using the appropriate lining can achieve a period of fire resistance of 'medium' duration, with reference to clause 2.3.1 ⁽¹⁾ of this Standard. See sections 13.1, 13.2 and 13.4 of this Certificate.
Standard:	2.4	Cavities
Comment:		Walls using an appropriate cavity barrier can satisfy this Standard, with reference to clauses 2.4.1 ⁽¹⁾ to 2.4.7 ⁽¹⁾ . See section 13.6 of this Certificate.
Standard:	2.6	Spread to neighbouring buildings
Comment:		Walls using the appropriate lining, can achieve a period of fire resistance of 'medium' duration, with reference to clause 2.6.1 ⁽¹⁾ of this Standard. See sections 13.1, 13.2 and 13.4 of this Certificate.
Standard:	3.15	Condensation
Comment:		The panels can adequately limit the risk of surface condensation and will contribute to minimising the risk of interstitial condensation, with reference to clauses 3.15.1 ⁽¹⁾ to 3.15.4 ⁽¹⁾ . See sections 10.1 and 10.2 of this Certificate.
Standard:	5.1	Resisting sound transmission to dwellings using appropriate constructions
Comment:		When installed with suitable flanking elements, separating walls incorporating the panels can satisfy this Standard, with reference to clauses 5.1.1 ⁽¹⁾ , 5.1.2 ⁽¹⁾ and 5.1.12 ⁽¹⁾ . See section 15.1 of this Certificate.
Standard:	6.1(b)	Carbon dioxide emissions
Standard:	6.2	Building insulation envelope
Comment:		Refer to clauses 6.1.2 ⁽¹⁾ , 6.1.6 ⁽¹⁾ , 6.2.1 ⁽¹⁾ , 6.2.4 ⁽¹⁾ and 6.2.5 ⁽¹⁾ . See sections 11.4, 11.5, 12.1 and 12.3 of this Certificate.
		(1) Technical Handbook (Domestic).

3 The Building Regulations (Northern Ireland) 2000 (as amended)

 In the opinion of the BBA, SIP Building System – SIP Loadbearing Wall and Roof Panels, if used in accordance with the provisions of this Certificate, will satisfy or contribute to satisfying the various Building Regulations as listed below.

Regulation:	B2	Fitness of materials and workmanship
Comment:		The panels are acceptable. See section 17.1 of this Certificate.
Regulation:	C5	Condensation
Comment:		The panels will contribute to minimising the risk of interstitial condensation. See sections 10.1 and 10.2 of this Certificate.

Regulation:	D1	Stability
Comment:		Walls and roofs constructed from the panels will have sufficient strength and stiffness when designed and constructed in accordance with sections 9.1 and 9.2 of this Certificate.
Regulation:	E4(1)(2)	Internal fire spread – Structure
Comment:		The panels can be used in walls required to have a fire resistance of 60 minutes. See sections 13.1 and 13.2 of this Certificate.
Regulation:	F2(a)(i)	Conservation measures
Comment:		See sections 11.4 and 11.5, 12.1 and 12.2 of this Certificate.
Regulation:	G2(i)	Separating walls and separating floors
Comment:		See section 15.1 of this Certificate.

4 Construction (Design and Management) Regulations 2007

Construction (Design and Management) Regulations (Northern Ireland) 2007

Information in this Certificate may assist the client, CDM co-ordinator, designer and contractors to address their obligations under these Regulations.

See sections: 5 Description (5.1), and 7 General (7.1 and 7.2) of this Certificate.

Technical Specification

5 Description

5.1 SIP Building System — SIP Loadbearing Wall and Roof Panels are structural elements consisting of internal and external skins of oriented strand board, Type 3 (OSB/3) to BS EN 300 : 1997, with an insulation core of closed cell polyurethane (PUR).

5.2 The panels have characteristics of:

overall stock thickness ⁽¹⁾ (mm)	75, 100, 125 and 150
OSB thickness (mm)	11 (15 optional)
insulation thickness (mm)	53 to 128
insulation density (kgm ⁻³)	38 to 45
overall size (m)	6.5 x 1.2
weight (kgm ⁻²)	18 to 25
edge detail	rebated, square.

(1) Other sizes are available to order within the range shown.

5.3 The panels are connected by the use of panel splines located in preformed rebates within the PUR core or timber inserts (see Figure 1). Openings are formed with pre-cut panels, incorporating timber lintels (see section 9.7).

Figure 1 Typical detail of spline connection

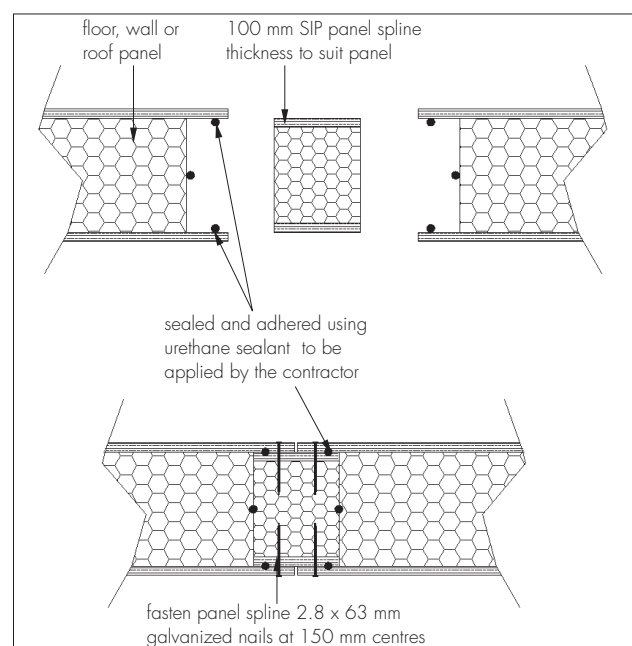

5.4 Ancillary items used with the panels include:

- sole plate — 75 mm to 150 mm by 40 mm deep, C24 treated timber to EN 338 : 2003, used to support the bottom channel (see BS 5268-5 : 1989 for required risk category)

- bottom and top plate — 53 mm to 128 mm by 50 mm treated softwood with chamfered top edges
- edge timber — minimum 50 mm by 76 mm, grade C16 timber
- lintels — treated softwood timber to Structural Engineer's design
- framing for openings — treated softwood timber to grade C24
- galvanized/shearardized ring-shank nails — in accordance with BS 5268-2 : 2002 and in sizes of 2.8 mm diameter by 63 mm and 3.75 mm diameter by 75 mm.

5.5 Other items used, but outside the scope of this Certificate, include:

- Glulam purlins
- standard nails — in accordance with BS 5268-2 : 2002
- joist hangers — as specified for the project. Fixings to be to the Certificate holder's instructions
- joists — as specified for the project. Fixings to be to the Certificate holder's instructions
- dry lining battens — minimum 38 mm wide by 11 mm deep softwood, OSB/3 or vertical metal rails
- silicone — one-part transparent silicone of density $>1020 \text{ kgm}^{-3}$, permissible deformation $>25\%$, UV and fungal resistant
- expanding urethane — gun-grade polyurethane based expanding one-part foam
- wall ties — Simpson Strong-tie BTS4 TEK wall-tie kits using ABC Spax stainless steel, flange-head, pozi-drive screws 30 mm by 4 mm
- counter battens — treated softwood counter battens, minimum 50 mm wide by 25 mm deep
- tiling/slate battens — sizing as per BS 5534 : 2003
- vapour permeable membrane — use as a roof tile underlay
- breather membrane — approved for use in wall construction.

6 Delivery and site handling

6.1 The panels are delivered in shrink-wrap, with edge protectors and banded packaging used for initial transit and temporary protection. They should be stored flat (no more than 10 panels high for up to 125 mm thickness and 8 high for 150 mm thickness) over suitable stillage to a slight fall (to allow rain run-off). Bearers should be at 600 mm (maximum) centres, (end bearers no more than 150 mm from edge of panel), and aligned vertically between individual packs in accordance with the Certificate holder's guidelines.

6.2 The panels and all components should be stored inside, or in dry, sheltered conditions at least 150 mm off the ground, covered with opaque

polythene sheeting or tarpaulin until the panels and components are to be used for erection.

6.3 The panels can withstand the normal loads associated with site handling and installation. Damaged panels should not be used.

6.4 Each panel bears the BBA identification mark incorporating the number of this Certificate.

Design Data

7 General

7.1 SIP Building System — SIP Loadbearing Wall and Roof Panels are suitable for use as loadbearing partitions, separating walls, the inner leaf of external walls and pitched roofs in dwellings up to two storeys high (plus room-in-roof). All structural calculations should be undertaken by a Chartered Structural Engineer who should contact the Certificate holder for full design guidance. All production drawings should be carried out by the Certificate holder or approved designers.

7.2 The cutting or forming of openings within wall or roof panels must be taken into account, in particular to the loadbearing capacity of individual elements and overall stability of the structure.

7.3 When panels are used to construct the inner leaf of an external cavity wall, the outer masonry leaf and all masonry below dpc must be built in accordance with BS 5628-3 : 2005 and roof tiles and slates applied in accordance with BS 5534 : 2003.

7.4 Foundations (outside the scope of this Certificate) must be approved for use by the Certificate holder's technical staff and should be suitably level and square to accept the wall panel.

7.5 Where buildings need to comply with NHBC Standards or *Zurich Building Guarantee Technical Manual 2007*, Section 4 *Superstructure*, specifiers should observe the requirements of these Standards.

7.6 Other wall and roof weatherproofing systems can be used, but are not covered by this Certificate.

8 Practicability of installation

The panels may be readily installed by contractors who have been trained and assessed to undertake this work. Any installation work should follow the details and information contained in the construction drawings, as prepared by the Certificate holder or approved designers.

9 Structural performance

 9.1 The wall and roof panels will have adequate strength and stiffness when used in accordance with the provisions of this Certificate.

9.2 The maximum permissible design values⁽¹⁾ that can be used when evaluating the vertical resistance of 100 mm thick wall panels with 11 mm OSB/3 skins, up to 3 m high are:

- 64⁽²⁾ kNm⁻¹ when axially loaded
 - 53⁽²⁾ kNm⁻¹ when eccentrically loaded by not more than 25 mm from centre line of the panel.
- (1) The values given in section 9.2 are for medium-term loads and are based on two sets of tests to failure of six panels using the methods of BS 5268-2 : 2002, Section 8. Data for other panel configurations is available on request. The engineer must take into account the reduction in axial load capacity that will occur when the panel is also subject to transverse loading such as wind. The values also assume a serviceability deflection limit of span/333 and any limitations that may be imposed due to fire resistance (see section 13).
- (2) Subject to suitable fire test data (see sections 13.1, 13.2 and 13.7).

9.3 Permissible transverse load values to be used when evaluating the design resistance of the panels are given in Table 1. The values are based on test results carried out on a 150 mm thick SIP with 11 mm OSB/3 skins and analysis carried out in accordance with BS 5268-2 : 2002.

Table 1 Permissible transverse load for 150 mm thick roof panels

Span condition	Load at span/333 (kNm ⁻²)	Admissible load with FOS of 2.25 applied (kNm ⁻²)
3 m double span	4.1	9.0
4 m single span	2.1	8.0

Notes:

- (1) Load limit assuming a serviceability deflection limit of span/333.
- (2) The figures are the result of short-term loading tests. When assessing deflections, the engineer must take into account simple bending, shear deflection and creep effects. The Certificate holder is able to provide further design advice on request.

9.4 The design engineer must take account of sliding, overturning and panel racking. The methods of BS 5268-6.1 : 1996 may be used to assess racking resistance. If the methods of clause 4.7.2(b) are used, a basic racking resistance⁽¹⁾⁽²⁾ of 5.40 kNm⁻¹ for wall panels, based on racking tests to BS EN 594 : 1996 and derived from BS 5268-6.1 : 1996, can be assumed. The number and size of openings together with the type and method of fixing to the sole plate and in turn, the sole plate to the foundation, will affect this figure. The design engineer should take both into account when producing stability calculations.

- (1) The basic racking resistance value assumes that the sole plate is glued to the foam infill and the OSB skins are then nailed to the sole plate using 50 mm long by 3.3 mm wire nails at 100 mm centres. Anchor bolts for fixing sole plate to test rig for the racking resistance tests were 12 mm diameter at 600 mm centres. Any changes to this assumption will affect the figure and the design engineer should modify the basic racking resistance accordingly. Alternatively the design engineer should adopt the basic racking resistance values set out in Table 2 of BS 5268-6.1 : 1996.
- (2) The racking resistance values may be modified by factors K104 to K108 in accordance with BS 5268-2 : 2002, Section 6.1 and 4.7.2 (b) to obtain design values.

9.5 The strength of all connection details which tie walls to other structural elements (such as walls, floors, roofs, OSB splines) must be evaluated and provide adequate stability for the overall building design. The specification and design for these items must be determined by the engineer responsible for the stability of the building. Guidance on the design of connection details may be obtained from the Certificate holder.

9.6 Lintels and framing around openings, form an integral part of the loadbearing wall panels (see Figure 2). The sizing of lintels must be determined by the engineer responsible for the design.

Figure 2 Typical lintel detail

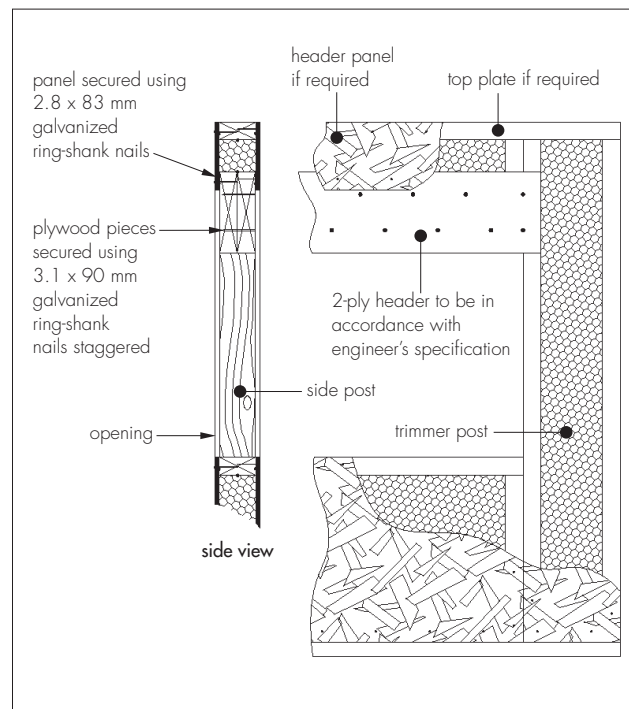

9.7 As part of the structural design, consideration should be given to the support of eccentric loads imparted by central heating systems or kitchen appliances.

9.8 Stainless steel wall ties⁽¹⁾ Type 5 or 6 to BS DD 140-2 : 1987 can be directly attached to the OSB/3 face of the panel using stainless-steel screw fasteners.

- (1) Wall tie centres 4.4 ties per m² on sites with basic wind speed up to and including 52 ms⁻¹, seven ties per m² for basic wind speed exceeding 52 ms⁻¹.

10 Condensation

Surface condensation



10.1 The risk of surface condensation in roofs and external walls, and at junction and opening details (see relevant Figures), will be minimal.

Interstitial condensation

10.2 The risk of interstitial condensation will be minimal when the panels are used in conjunction with a vapour check plasterboard lining, or other

suitably installed vapour control layer. For the purposes of calculating condensation risk, in accordance with BS 5250 : 2002, vapour diffusion factors (μ) of 23 and 50 may be used for the polyurethane insulation and the OSB/3, respectively.

11 Thermal properties

11.1 The thermal performance of each building incorporating the panels must be evaluated in accordance the relevant national Building Regulations and is the responsibility of the overall designer of the building.

11.2 Calculations of the thermal transmittance of specific constructions should be based on thermal conductivity values ($Wm^{-1}K^{-1}$) of:

polyurethane insulation core	0.025
OSB/3	0.13

11.3 Typical U values for building elements, calculated in accordance with BS EN ISO 6946 : 1997 and BRE report (BR 443 : 2006) *Conventions for U-value calculations* are given in Table 2.

Element	Panel thickness (mm)	U value ⁽¹⁾ ($Wm^{-2}K^{-1}$)
External wall ⁽²⁾	100	0.27
	125	0.21
	150	0.17
Roof ⁽³⁾	150	0.18

- (1) All panels include 11 mm OSB and assume no timber bridging.
 (2) The wall comprises 12.5 mm thick plasterboard on battens, a 50 mm wide cavity and brick outer leaf.
 (3) The roof comprises panels lined internally with 12.5 mm thick plasterboard on battens with a slated or tiled exterior.



11.4 The panels contribute to meeting the requirements of the national Building Regulations, thus:

England and Wales and Northern Ireland

- the roof described in Table 2 cannot achieve the specified U value of:
 - 0.16 $Wm^{-2}K^{-1}$ 'notional' dwellings in SAP 2005⁽¹⁾
- the roof described in Table 2 can achieve the specified U values of:
 - 0.25 $Wm^{-2}K^{-1}$ limit average in Approved Document L1A, Table 2, and Technical Booklet F1, Table 2.2
 - 0.35 $Wm^{-2}K^{-1}$ limit for an individual element in Approved Document L1A, Table 2 and Technical Booklet F1, Table 2.2
- walls described in Table 2, can achieve the specified value of:
 - 0.35 $Wm^{-2}K^{-1}$ for a 'notional' dwelling in SAP 2005 and improve on this value by from 23% to 51%
 - 0.35 $Wm^{-2}K^{-1}$ limit average in Approved Document L1A, Table 2, and Technical Booklet F1, Table 2.2

- 0.70 $Wm^{-2}K^{-1}$ limit for an individual element in Approved Document L1A, Table 2, and Technical Booklet F1, Table 2.2.

Scotland

- the roof described in Table 2, cannot achieve the specified U value of:
 - 0.16 $Wm^{-2}K^{-1}$ for a 'notional' domestic roof, with reference to Mandatory Standard 6.1, clauses 6.1.2⁽²⁾ and 6.1.6⁽²⁾ and SAP 2005⁽¹⁾
- the roof described in Table 2 can achieve the specified values of:
 - 0.20 $Wm^{-2}K^{-1}$ maximum average, with reference to Mandatory Standard 6.2, clause 6.2.1⁽²⁾
 - 0.35 $Wm^{-2}K^{-1}$ maximum for an individual element, with reference to Mandatory Standard 6.2, clause 6.2.1⁽²⁾.
- walls described in Table 2 can achieve the specified U values of:
 - 0.20 $Wm^{-2}K^{-1}$ for the simplified approach — solid fuel (package 6) given in Mandatory Standard 6.1, clause 6.1.6⁽²⁾
 - 0.25 $Wm^{-2}K^{-1}$ for 'notional' dwellings in SAP 2005 and the simplified approach — fuel (packages 1 to 5) given in Mandatory Standard 6.1, clause 6.1.6⁽²⁾
 - 0.30 $Wm^{-2}K^{-1}$ limit average in Mandatory Standard 6.2, clause 6.2.1⁽²⁾
 - 0.70 $Wm^{-2}K^{-1}$ limit for an individual element in Mandatory Standard 6.2, clause 6.2.1⁽²⁾.

- (1) Where a proposed element U value is not better than (or greater than in Scotland) the relevant 'notional' value specified, additional energy saving measures will be required in the building envelope and/or services to achieve the required overall carbon dioxide emission rate reduction of about 20%, or 18% to 25% in Scotland.
 (2) Technical Handbook (Domestic).

Junctions

11.5 Junctions shown in this Certificate adequately limit heat loss by conduction and, when installed to limit air infiltration (see sections 12.1 to 12.3), comply with the requirements of the Accredited Construction Details (version 1.0), and the Accredited Construction Details (Scotland). The relevant default psi values quoted in BRE Information Paper IP 1/06 *Assessing the effects of thermal bridging at junctions and around openings*, Table 3, may be used for these junctions in SAP calculations.

12 Air permeability



12.1 Dwellings incorporating the panels can achieve adequate air barrier continuity provided there is effective sealing around junctions, openings and penetrations.



12.2 In England and Wales and Northern Ireland, dwellings are subject to pre-completion testing for airtightness in accordance with the requirements of Approved

Document L1A, Section 20B, and Technical Booklet F1, Sections 2.49 to 2.54, respectively.



12.3 In Scotland, if the dwelling is designed and built in accordance with the requirements of the Accredited Construction Details (Scotland) the air permeability may be taken as $10 \text{ m}^3\text{m}^{-2}\text{h}^{-1}$ at 50 Pa, and testing is not considered necessary. If the aforementioned details are not complied with, and the designer does not wish to accept a default figure of $15 \text{ m}^3\text{m}^{-2}\text{h}^{-1}$, or if an air permeability better than $10 \text{ m}^3\text{m}^{-2}\text{h}^{-1}$ is claimed, then testing should be carried out.

13 Behaviour in relation to fire



13.1 When tested to BS 476-21 : 1987, the panel system achieved the results shown in Table 3.

Table 3 Fire performance

Performance	Axial load (kNm ⁻¹)	Construction
FR30	8.33	12.5 mm fire-resistant plasterboard fixed directly to OSB or via 38 mm x 25 mm battens
FR60	13	One layer of 19 mm fire-resistant plasterboard, plus one layer of 12.5 mm plasterboard fixed directly to OSB

13.2 Assessment of test results and design details show that panels are suitable for use in external walls (with service loads up to the stated values in Table 3), not less than one metre from a relevant boundary, and in separating walls that require fire resistance periods not less than the following:

External walls 30⁽¹⁾ or 60⁽²⁾ minutes (from inside)⁽²⁾
 Separating walls 60 minutes (from either side)⁽²⁾

(1) 'Short' duration in Scotland.
 (2) 'Medium' duration in Scotland.

13.3 The OSB/3 panel linings have a Class 3⁽¹⁾ surface spread of flame designation.

(1) 'High risk' in Scotland.



13.4 Junctions between the panels in external and separating walls will adequately maintain the fire resistance of the separating wall.

13.5 The panels can form part of a separating wall between dwellings in Scotland in accordance with the exceptions permitted by Mandatory Standard 2.2, with reference to clause 2.2.7⁽¹⁾.

(1) Technical Handbook (Domestic).

13.6 Constructions incorporating the wall and roof panels must include suitable provision for cavity barriers and for fire stopping at junctions with other elements in accordance with the requirements of national Building Regulations (see Figure 3).

13.7 Where a greater load capacity to that given in Table 3 or where any other form of wall construction incorporating the panels (including

any service penetrations) is subject to fire-resistance requirements, an appropriate assessment or test must be carried out by a UKAS (United Kingdom Accreditation Service) approved testing laboratory.

13.8 The external fire rating of any roof incorporating the system panels will depend on the specification of the roof covering used.

Figure 3 Typical separating wall detail (fire stopping)

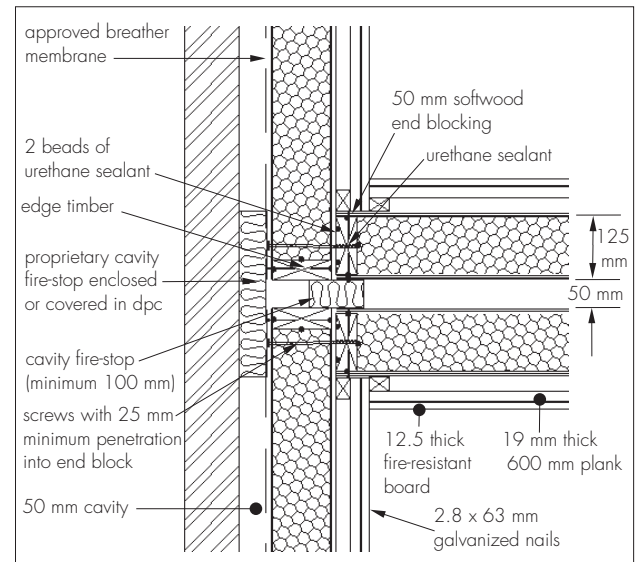

14 Proximity of flues and appliances

When installing the product in close proximity to certain flue pipes and/or heat producing appliances, the following provisions to the national Building Regulations are acceptable:

England and Wales

Approved Document J

Scotland

Mandatory Standard 3.18

Northern Ireland

Technical Booklet L.

15 Sound insulation



15.1 Test data to BS EN ISO 140-3 : 1995 indicate that the separating wall construction detailed in Figure 3 can provide satisfactory resistance to airborne sound transmission, when used in conjunction with suitable flanking elements (see Tables 4, 5 and 6).

Table 4 Airborne sound insulation (dB) — Laboratory test results

Construction	(dB)
Separating wall (Figure 3)	$R_w (C_i; C_{tr}) = 60 (-2; -8)$ $\therefore R_w - C_{tr} = 52$
Internal wall ⁽¹⁾	$R_w = 42$

(1) Internal wall comprising a single 100 mm thick panel lined each side with 12.5 mm thick sound-resistant plasterboard.

Table 5 Airborne sound insulation (dB). Deemed to satisfy — England and Wales

Construction	Mean value (dB)
Separating walls — dwelling-houses and flats	$D_{nT,w} + C_{tr} \geq 45$
Internal walls — between a bedroom or a WC and other rooms	$R_w \geq 40$

Table 6 Airborne sound insulation (dB). Deemed to satisfy — Scotland and Northern Ireland

Construction	Mean value (dB)
Separating walls — dwelling-houses and flats	$D_{nT,w} \geq 53$



15.2 Test data to BS EN ISO 140-3 : 1995 indicate that the single leaf internal wall acoustic (non-loadbearing) construction can provide satisfactory resistance to airborne sound transmission within a dwelling for walls between a WC or bathroom and another room in England and Wales (see Tables 4 and 5).

15.3 In England and Wales, separating walls are subject to pre-completion testing in accordance with Section 1 of Approved Document E.

15.4 It is essential that care is taken in design and during installation to avoid direct paths for airborne sound transmission and to minimise paths for flanking sound transmission.

16 Weathertightness

16.1 When the panels are used to form the inner leaf of an external cavity wall, the outer masonry leaf must be designed and constructed in accordance with BS 5628-3 : 2005 incorporating damp-proof courses and cavity trays. A breather membrane is required with this type of construction.

16.2 When used with other outer leaf construction, cladding or render systems the final weather resistance of the building is dependent upon the efficient positioning and sealing of all joints. The guidance given in Section 3 of BRE report (BR 262 : 2002) *Thermal insulation : avoiding risks* should be followed with regard to rain penetration in that the designer selects a construction appropriate to the local wind-driven rain index, paying due regard to the design detailing, workmanship and materials to be used.

16.3 Roofing should be in accordance with BS 5534 : 2003 detailed to ensure moisture is prevented from coming into contact with the panels.

16.4 The performance of windows and doors is not covered by this Certificate.

17 Durability



17.1 The panels will have comparable durability to that of OSB/3 to BS EN 300 : 1997, therefore, provided the installation remains weathertight, a life of at least 60 years may be expected.

17.2 Timber used in areas that could be at risk, eg sole plates, should be preservative-treated in accordance with the recommendations given in BS 1282 : 1999.

Installation

18 General

18.1 Erection of the SIP Building System — Loadbearing Wall and Roof Panels must comply with the details given in the Certificate holder's construction manual and the provisions of this Certificate.

18.2 The main contractor must ensure that the accuracy of the foundation is in accordance with the Certificate holder's instructions, in particular, the following details must be within the tolerance of ± 5 mm:

- the level of the foundation or other bearing support
- the overall width and length of the building footprint
- the diagonals used for checking the overall squareness of the building.

19 Procedure

Foundation construction

19.1 A suitable damp-proof course (dpc) is laid on top of the foundation (see Figure 4).

Figure 4 Typical ground-floor construction

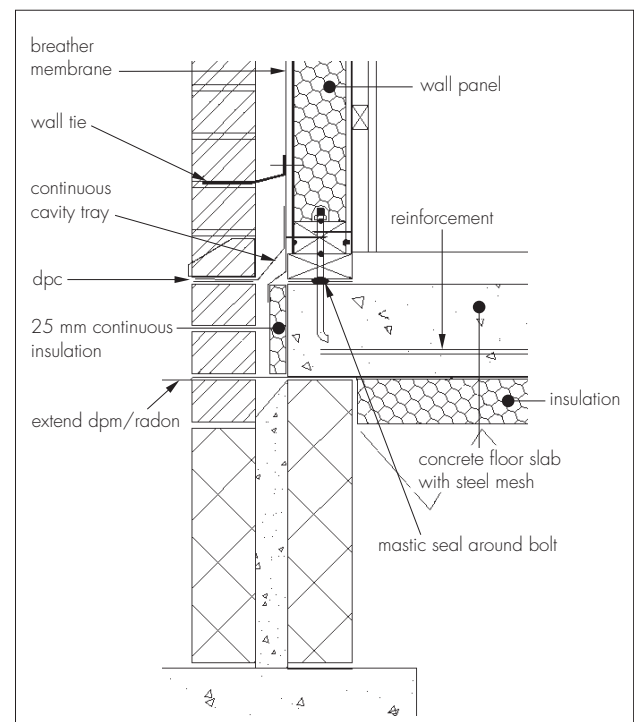

19.2 A 40 mm deep, treated timber sole plate (see Figure 5) is positioned over the dpc and fixed to the foundation using fixings as approved by the Certificate holder and the Chartered Engineer's requirements. Typically, a holding down bolt

arrangement (see Figure 6) should be used for securing into a concrete raft foundation, strapping where required onto masonry. Sole plates can be adjusted using galvanized or stainless steel shims and proprietary injectable mortar grouting is introduced to seal against air infiltration, if required.

Ground-floor construction

19.3 A bead of urethane sealant is run along the top of sole plate and a 50 mm deep, treated timber bottom plate, with chamfered top edges, secured to the sole plate using galvanized ring-shank nails or screws at centres approved by the Certificate holder. Starting at one corner (see Figure 6), the first panel is positioned correctly on the bottom plate, plumbed vertical and fixed to the bottom plate section with galvanized ring-shank nails or screws at centres approved by the Certificate holder, through the OSB inner and outer skins. This forms the standard basis for connecting all ground-floor panel runs or corner junctions. Panels are temporarily braced to maintain stability. Wall panels are assembled using a spline joint connection. All vertical joints are sealed using urethane sealant. Spline joints of the panel can be tightened using a timber mallet taking care not to damage OSB edges.

First floor and room-in-roof construction

19.4 Engineered or traditional timber floor joists are supported either from the head of the wall panel or side of panel using joist hangers, fixed by nailing into the head plate using galvanized ring-shank nails or screws approved by the Certificate holder (see Figure 7). Where the floor construction is supported the wall panel head, a timber rim beam is introduced to partly support the upper wall panel (see Figure 7b).

19.5 A 50 mm deep timber bottom plate (see Figure 7) is nailed through the floor decking into the head plate or rim beam. The procedure used for the ground-floor construction is followed.

Roof construction

19.6 The external and internal first floor walls are stiffened through the use of intermediate/ridge beams/purlins as per design requirements (see Figure 8). Structural elements are located within preformed pockets in the wall panel. A wall plate is fixed onto the top of the head plate with the top angled to suit the pitch of the roof.

19.7 Roof panels are positioned working from one gable wall to the other. Panels are joined (as for the wall construction) and fixed through to the structural supporting timber members using Sparrenagel or the Certificate holder's approved screw fasteners and to the engineer's design requirements. The roof panel is overlaid with a vapour permeable membrane. Treated softwood counter battens, minimum 25 mm deep by 50 mm wide, are then fixed through to the roof panel using stainless-steel screws as approved by the Certificate holder and

to the engineer's design requirements. A variety of roof finishes (see section 5.7) can be adopted, subject to Certificate holder's approval (see Figures 8 and 9).

Figure 5 Typical sole plate detail

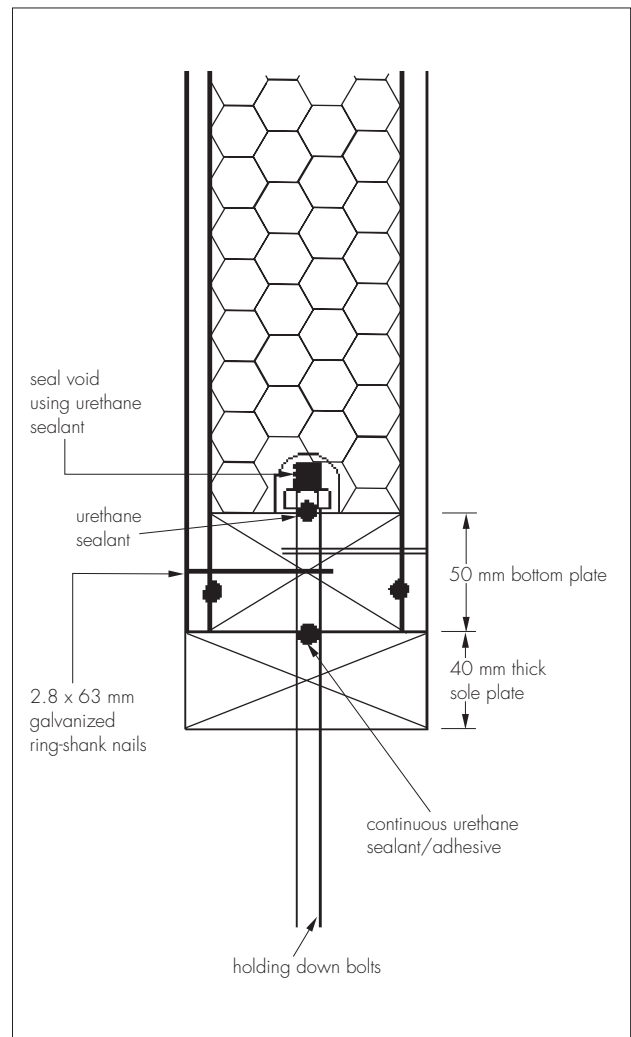

Figure 6 Typical corner joint detail

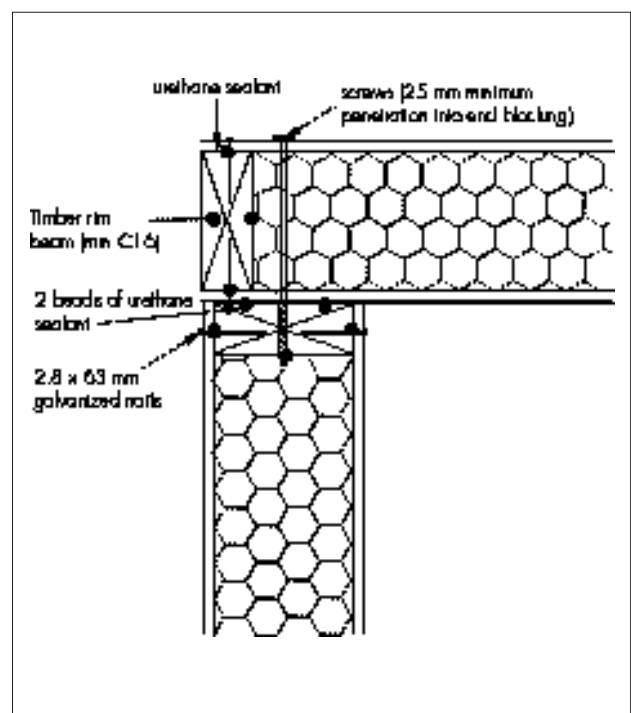

Figure 7 Typical first-floor construction

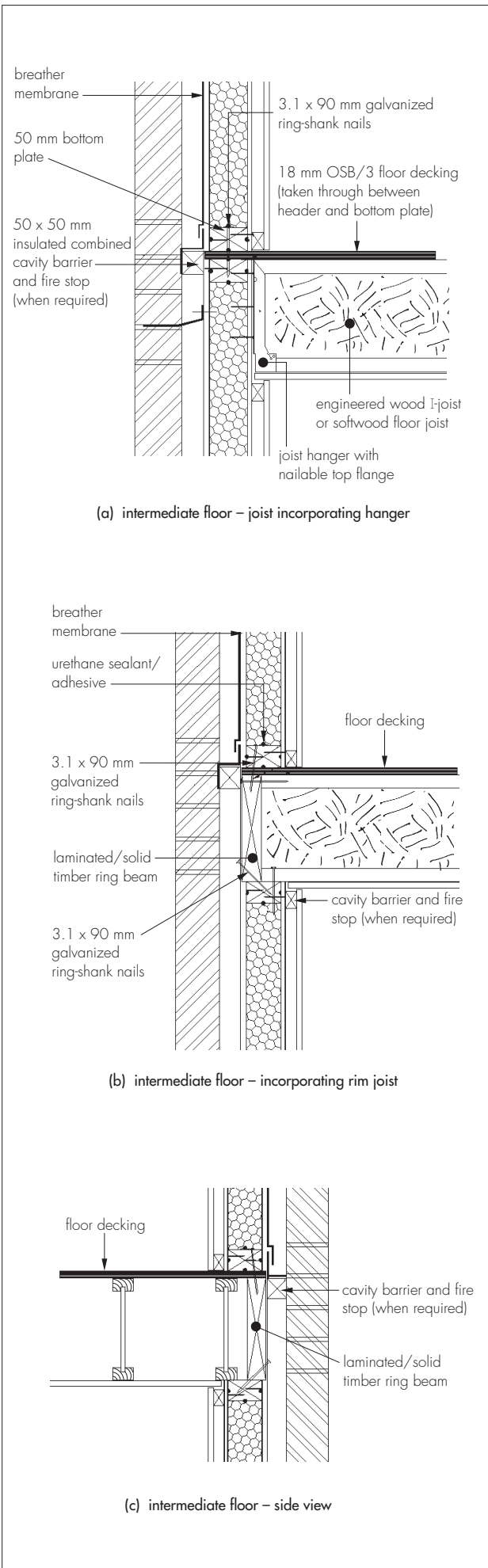

Figure 8 Typical roof detail at ridge

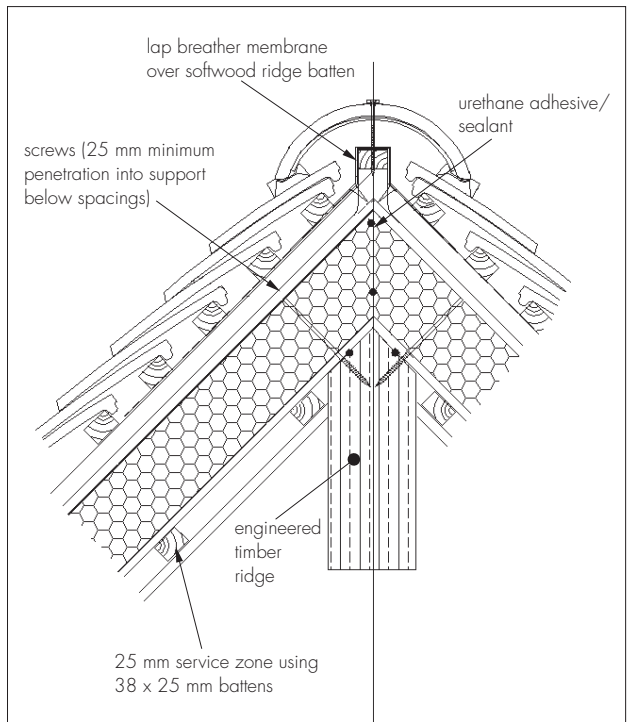
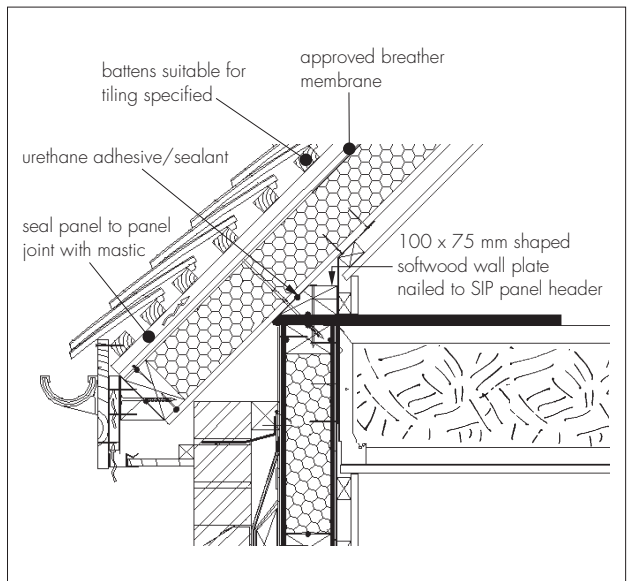

Figure 9 Typical eaves detail



Technical Investigations

The following is a summary of the technical investigations carried out on the Build It Green System — SIP Loadbearing Wall and Roof Panels.

20 Tests

Tests were carried out to determine:

- racking resistance in accordance with BS 5268-6.1 : 1996 and BS EN 594 : 1996
- vertical loading
- pull-out strength of wall ties based on BS DD 140-2 : 1987 and BS EN 846-6 : 2000
- fire-resistance to BS 476-21 : 1987.

21 Investigations

An examination was made of technical data relating to:

- structural properties and design calculations
- airborne sound insulation tests
- air leakage tests.

22 Other investigations

22.1 The manufacturing process was examined, including the methods adopted for quality control, and details were obtained of the quality and composition of materials.

22.2 A visit was made to a site in the UK to assess the installation process.

Bibliography

BS 476-21 : 1987 *Fire tests on building materials and structures — Methods for determination of the fire resistance of loadbearing elements of construction*

BS 1282 : 1999 *Wood preservatives — Guidance on choice, use and application*

BS 5250 : 2002 *Code of practice for control of condensation in buildings*

BS 5268-2 : 2002 *Structural use of timber — Code of practice for permissible stress design, materials and workmanship*

BS 5268-5 : 1989 *Structural use of timber — Code of practice for the preservative treatment of structural timber*

BS 5268-6.1 : 1996 *Structural use of timber — Code of practice for timber frame walls — Dwellings not exceeding four storeys*

BS 5534 : 2003 *Code of practice for slating and tiling (including shingles)*

BS 5628-3 : 2005 *Code of practice for the use of masonry — Materials and components, design and workmanship*

BS DD 140-2 : 1987 *Wall ties — Recommendations for design of wall ties*

BS EN 300 : 2006 *Oriented Strand Boards (OSB) — Definitions, classification and specifications*

BS EN 594 : 1996 *Timber structures — Test methods — Racking strength and stiffness of timber frame wall panels*

BS EN 846-6 : 2000 *Methods of test for ancillary components for masonry — Determination of tensile and compressive load capacity and load displacement characteristics of wall ties (single end test)*

BS EN ISO 140-3 : 1995 *Acoustics — Measurement of sound insulation in buildings and of building elements — Laboratory measurement of airborne sound insulation of building elements*

EN 338 : 2003 *Structural timber — Strength classes*

Conditions of Certification

23 Conditions

23.1 This Certificate:

- relates only to the product/system that is named and described on the front page
- is granted only to the company, firm or person named on the front page — no other company, firm or person may hold or claim any entitlement to this Certificate
- is valid only within the UK
- has to be read, considered and used as a whole document — it may be misleading and will be incomplete to be selective
- is copyright of the BBA
- is subject to English law.

23.2 References in this Certificate to any Act of Parliament, Statutory Instrument, Directive or Regulation of the European Union, British, European or International Standard, Code of Practice, manufacturers' instructions or similar publication, are references to such publication in the form in which it was current at the date of this Certificate.

23.3 This Certificate will remain valid for an unlimited period provided that the product/system and the manufacture and/or fabrication including all related and relevant processes thereof:

- are maintained at or above the levels which have been assessed and found to be satisfactory by the BBA
- continue to be checked as and when deemed appropriate by the BBA under arrangements that it will determine

- are reviewed by the BBA as and when it considers appropriate.

23.4 In granting this Certificate, the BBA is not responsible for:

- the presence or absence of any patent, intellectual property or similar rights subsisting in the product/system or any other product/system
- the right of the Certificate holder to manufacture, supply, install, maintain or market the product/system
- individual installations of the product/system, including the nature, design, methods and workmanship of or related to the installation
- the actual works in which the product/system is installed, used and maintained, including the nature, design, methods and workmanship of such works.

23.5 Any information relating to the manufacture, supply, installation, use and maintenance of this product/system which is contained or referred to in this Certificate is the minimum required to be met when the product/system is manufactured, supplied, installed, used and maintained. It does not purport in any way to restate the requirements of the Health & Safety at Work etc Act 1974, or of any other statutory, common law or other duty which may exist at the date of this Certificate; nor is conformity with such information to be taken as satisfying the requirements of the 1974 Act or of any statutory, common law or other duty of care. In granting this Certificate, the BBA does not accept responsibility to any person or body for any loss or damage, including personal injury, arising as a direct or indirect result of the manufacture, supply, installation, use and maintenance of this product/system.



In the opinion of the British Board of Agrément, SIP Building System — SIP Loadbearing Wall and Roof Panels are fit for their intended use provided they are installed, used and maintained as set out in this Certificate. Certificate No 06/4312 is accordingly awarded to SIP Building Systems Ltd.

On behalf of the British Board of Agrément

Date of Second issue: 27th July 2007

A handwritten signature in black ink, appearing to read 'G. A. Cooper', is written over a white background.

Chief Executive

**Original Certificate issued 20th April 2006. This amended version includes revisions to the Thermal properties, Air permeability and Sound insulation sections and new Conditions of Certification.*

***Certificate amended 7th August 2008 to advise of the availability of sizes outside the stock range (section 5.2).*