



Cowen Windows Ltd

Unit 2, Cholmley Way
Eskdale Industrial Estate
Whitby
North Yorkshire YO22 4NJ
Tel: 01947 603923 Fax: 01947 821878
e-mail: infocowenwindowsltd@fsmail.net
website: www.cowenwindows.co.uk

**Agrément
Certificate No
09/4696**

Designated by Government
to issue
European Technical
Approvals

VEKA PVC-U WINDOW SYSTEM

Fenêtre
Fenster

Product



• THIS CERTIFICATE RELATES TO THE VEKA PVC-U WINDOW SYSTEM, COMPRISING THE WINDOW TYPES AND SIZES REFERRED TO IN THE ACCOMPANYING DETAIL SHEETS.

- The windows referred to in the Detail Sheets are fabricated and marketed by Cowen Windows Ltd at the above address.
- The windows in the Veka range are for use in the exposure situations described in the relevant Detail Sheets.
- It is essential that the windows are installed and used in accordance with the conditions set out in the Design Data and Installation parts of the Detail Sheets.

Regulations

1 The Building Regulations (England and Wales)

 The Secretary of State has agreed with the British Board of Agrément the requirements of the Building Regulations to which windows can contribute in achieving compliance. In the opinion of the BBA, the position of the Veka PVC-U Window System under the Regulations, if used in accordance with the provisions of this Certificate, is as stated in Detail Sheet 1.

2 The Building Standards (Scotland) Regulations

 In the opinion of the BBA, the position of the Veka PVC-U Window System under these Regulations, if used in accordance with the provisions of this Certificate, is as stated in Detail Sheet 1.

3 The Building Regulations (Northern Ireland)

 In the opinion of the BBA, the position of the Veka PVC-U Window System under these Regulations, if used in accordance with the provisions of this Certificate, is as stated in Detail Sheet 1.

4 Construction (Design and Management) Regulations

In the opinion of the BBA, the position of the Veka PVC-U Window System under these Regulations, if used in accordance with the provisions of this Certificate, is as stated in Detail Sheet 1.

Conditions of Certification

5 Conditions

5.1 This Certificate:

- relates only to the product/system that is named and described on the front page
- is granted only to the company, firm or person named on the front page — no other company, firm or person may hold or claim any entitlement to this Certificate
- is valid only within the UK
- has to be read, considered and used as a whole document — it may be misleading and will be incomplete to be selective
- is copyright of the BBA
- is subject to English law.

5.2 Publications and documents referred to in this Certificate are those that the BBA deems to be relevant at the date of issue or re-issue of this Certificate and include any: Act of Parliament; Statutory Instrument; Directive; Regulation; British, European or International Standard; Code of Practice; manufacturers' instructions; or any other publication or document similar or related to the aforementioned.

5.3 This Certificate will remain valid for an unlimited period provided that the product/system and the manufacture and/or fabrication including all related and relevant processes thereof:

- are maintained at or above the levels which have been assessed and found to be satisfactory by the BBA
- continue to be checked as and when deemed appropriate by the BBA under arrangements that it will determine

- are reviewed by the BBA as and when it considers appropriate.

5.4 In granting this Certificate, the BBA is not responsible for:

- the presence or absence of any patent, intellectual property or similar rights subsisting in the product/system or any other product/system
- the right of the Certificate holder to manufacture, supply, install, maintain or market the product/system
- individual installations of the product/system, including the nature, design, methods and workmanship of or related to the installation
- the actual works in which the product/system is installed, used and maintained, including the nature, design, methods and workmanship of such works.

5.5 Any information relating to the manufacture, supply, installation, use and maintenance of this product/system which is contained or referred to in this Certificate is the minimum required to be met when the product/system is manufactured, supplied, installed, used and maintained. It does not purport in any way to restate the requirements of the Health & Safety at Work etc Act 1974, or of any other statutory, common law or other duty which may exist at the date of this Certificate; nor is conformity with such information to be taken as satisfying the requirements of the 1974 Act or of any statutory, common law or other duty of care. In granting this Certificate, the BBA does not accept responsibility to any person or body for any loss or damage, including personal injury, arising as a direct or indirect result of the manufacture, supply, installation, use and maintenance of this product/system.



In the opinion of the British Board of Agrément, the Veka PVC-U Window System is fit for its intended use provided it is installed, used and maintained as set out in this Certificate. Certificate No 09/4696. is accordingly awarded to Cowen Windows Ltd.

On behalf of the British Board of Agrément

Date of First issue: 2nd December 2009

Head of Approvals
— Physics

Chief Executive

Associated Detail Sheets

The following Detail Sheets are part of this Certificate:

Detail Sheet	Edition	Date of issue	No of pages	Imprint ref	Title	System status
—	1	2nd December 2009	2	4696ER1	Enhanced Resistance to Intrusion ⁽¹⁾	Current
1	18	20th July 2009	4	18BRW1	PVC-U Window System Building Regulations	Current
7	1	2nd December 2009	8	01VPW7	The Veka Matrix FS70 Outward Opening PVC-U Window System	Current

(1) The *Enhanced Resistance to Intrusion sheet* (4696ER1) is only applicable to the types and specifications of windows detailed in Section 2 *Scope of approval* in the sheet.

VEKA PVC-U WINDOW SYSTEM ENHANCED RESISTANCE TO INTRUSION

Product



CAUTION: This sheet is not valid in isolation and must be read in conjunction with Detail Sheet 7. The information in this sheet supplements the details given in Detail Sheet 7 (Edition 1), section 10, *Security against intrusion*.

- The details in this sheet are only relevant to windows fabricated by Cowen Windows Ltd and meeting the specification defined in section 2, Scope of approval.
- It is essential that the windows are installed in accordance with the recommendations contained in Detail Sheet 7 (Edition 1), and in the manufacturer's instructions to achieve the standard of enhanced resistance defined in this sheet.

Enhanced Resistance to Intrusion

1 General

Selected windows from the Veka Matrix FS70 Outward Opening PVC-U Window System covered by Detail Sheet 7 (Edition 1) were tested in accordance with BS 7950 : 1997 *Specification for enhanced security performance of casement and tilt/turn windows for domestic applications* and met the requirements.

2 Scope of approval

2.1 The specification for the windows considered to offer enhanced resistance to intrusion comprises windows with glazing units (see Table 1 for size), fabricated from components as listed in Table 1, and in accordance with the recommendations contained in the *Veka Profile System Matrix FS70 Manual*.

2.2 The scope of the test programme does not cover glass breakage as a means of entry. In locations where this is considered to be a significant risk the use of laminated glass or other suitable glazing material may be necessary.

3 Design features

3.1 All main frame, opening light, mullion and transom (welded) profiles must be reinforced with galvanized steel in accordance with the recommendations contained in the *Veka Profile System Matrix FS70 Manual*.

3.2 Fittings and hardware, including their fixings, must be as detailed in accordance with the *Veka Profile System Matrix FS70 Manual*.

4 Design considerations

4.1 Only the specification of windows referred to in section 2.1 can be considered to meet the requirements. Any design variations to the frame profiles, internal reinforcement, locking mechanisms, handles, keeps, striker plates, hinges or associated fasteners, will require the window to be retested.

4.2 To ensure the level of resistance to intrusion indicated by the tests is achieved, installation must be carried out in accordance with the recommendations contained in Detail Sheet A (Edition 1) and the manufacturer's instructions. For example, correct glass packing and fixing of the window into the opening are critical.

4.3 Windows assessed for enhanced resistance to intrusion are designed to resist attempts to force entry by the opportunist intruder using basic hand tools. However, the scope of assessment does not extend to an assurance of absolute security. In addition, window security must be considered in the context of the overall security of the building, taking into account such factors as vulnerability of individual windows and the security of doors. Reference should be made to recommendations given by ABI⁽¹⁾, BRE⁽¹⁾, CWCT⁽¹⁾, GGF⁽¹⁾, NHBC⁽¹⁾ and local police Secured by Design schemes.

- (1) ABI Association of British Insurers
BRE Building Research Establishment
BSI British Standards Institution (Product Certification)
CWCT Centre for Window and Cladding Technology
GGF Glass and Glazing Federation
NHBC National House-Building Council.

Table 1 List of components

	Application	Profile type/ Section or quantity	Manufacturer's designation ⁽¹⁾ (Art No)
Profiles	outer frame ⁽²⁾	L	101.160
	mullion/transom ⁽²⁾	Z	102.260
	mullion/transom ⁽²⁾	T	102.261
	sash ⁽²⁾	T	103.264
	galvanized steel reinforcement for 103.264	—	113.039
	galvanized steel reinforcement for 102.260 and 102.261	—	113.041
	galvanized steel reinforcement for 101.160	—	113.245
	galvanized steel reinforcement for 101.160	—	113.317
	galvanized steel reinforcement for 103.264	—	113.372
Glazing retention	internal glazing beads and gaskets		
	glazing bead	—	107.155
	external gasket	—	112.272
	internal gasket	—	112.414
Furniture and fittings	espagnolette/shootbolt handle, key locking Maco MK II	—	✓
	hinge protectors Nico X-TRA bolt	—	✓
	friction stays Nico High Security	—	✓
	cavity wedges	—	109.265
	run-up blocks	—	109.380

(1) These items may be unmarked and it is recommended that, if in doubt, the purchaser seeks written assurance of the component specifications from the Certificate holder.

(2) With rolled-in gasket 112.272.



On behalf of the British Board of Agrément

Date of First issue: 2nd December 2009

cc A
Head of Approvals
— Physics

G.A. Cooper
Chief Executive

Regulations

1 The Building Regulations 2000 (as amended) (England and Wales)



The Secretary of State has agreed with the British Board of Agrément the requirements of the Building Regulations to which windows can contribute in achieving compliance. In the opinion of the BBA, the PVC-U Window System specified on the Front Sheet, if used in accordance with the provisions of this Certificate, will meet or contribute to meeting the relevant requirements.

Requirement: **B1**

Means of warning and escape

Comment:

Where a window is required in a dwelling, to provide a means of escape from an inner room or a loft space converted into a habitable room, the window can meet this Requirement when it incorporates an opening light providing a clear opening area of at least 0.33 m² and not less than 450 mm high by 450 mm wide and is positioned as set out in Approved Document B. The obstruction caused by opening lights hung on projecting friction stays must be taken into account when the clear opening is determined. However, the route through the window can be at an angle rather than straight through. Windows must remain open without needing to be held.

Requirement: **F1**

Means of ventilation

Comment:

In calculating the contribution of the product to natural purge ventilation, the area of opening should be calculated in accordance with the relevant tinted area in the *Ventilation* section (6.1) in the accompanying Detail Sheet(s) and related to floor area as set out in Approved Document F. Background ventilation can be provided by the methods described in the relevant tinted area in the *Ventilation* section (6.2) of the accompanying Detail Sheet(s).

Requirement: **K4**

Protection from collision with open windows etc

Comment:

In buildings other than dwellings, this Requirement can be met by installing windows so that projecting parts are kept away from people moving in and around the building; or by installing features which guide people away from any open window. Approved Document K sets out some ways of complying with this Requirement.

Requirement: **L1(a)(i)**

Conservation of fuel and power

Comment:

In meeting this Requirement, the U values given in the *Thermal insulation* section (7.1 and 7.2) of the accompanying Detail Sheet(s) should be used. For glazing other than that described in the accompanying Detail Sheet(s), the indicative U values shown in Table 6e of SAP 2005, *The Government's Standard Assessment Procedure for Energy Rating of Dwellings* can be used. When available, a certified U value by measurement or calculation, in accordance with the relevant Standards, should be used. In replacement work, an average elemental U value of 2.0 Wm⁻²K⁻¹ (dwellings) or 2.2 Wm⁻²K⁻¹ (buildings other than dwellings) is required for PVC-U windows. This can be met by the use of 4/16/4 mm double-glazed units with a low-E coating of emissivity 0.15 or better. Alternatively, a window with a window energy rating of Band E for replacement work is acceptable. New windows in extensions require a U value of 1.8 Wm⁻²K⁻¹ or a window energy rating of Band D.

Requirement: **N1**

Protection against impact

Requirement: **N2**

Manifestation of glazing

Comment:

Glazing less than 800 mm above floor or ground level should meet the requirements of N1. Except where windows incorporate only small panes, glass and plastics sheet materials

Requirement: N3	which satisfy the test requirements of BS EN 12600 : 2002 or BS 6206 : 1981 should be used to meet the requirements of N1. See the relevant tinted area in the <i>Safety</i> section (9.3) of the accompanying Detail Sheet(s). To meet the requirements of N2, it may be necessary to incorporate features into glazing in non-domestic buildings to make its existence apparent to people using them.
Comment:	Safe opening and closing of windows etc In buildings other than dwellings, windows which can be opened by people in or about the building should be constructed or equipped so that they can be opened, closed or adjusted safely. See the relevant tinted areas in the <i>Safety</i> section (9.1 and 9.2) of the accompanying Detail Sheet(s).
Requirement: N4	Safe access for cleaning windows etc
Comment:	In buildings other than dwellings, this Requirement can be met where provision is made for safe means of access for cleaning both sides of glazed surfaces where there is danger of falling more than two metres. Approved Document N sets out some ways of complying with this Requirement.
Requirement: Regulation 7	Materials and workmanship
Comment:	The system is acceptable. See the tinted areas in the <i>Durability</i> section (13.1 to 13.3) and the <i>Installation</i> part of the accompanying Detail Sheet(s).

2 The Building (Scotland) Regulations 2004 (as amended)



In the opinion of the BBA, the PVC-U Window System specified on the Front Sheet, if used in accordance with the provisions of this Certificate, will satisfy or contribute to satisfying the various Regulations and related Mandatory Standards as listed below.

Regulation: 8(1)(2)	Fitness and durability of materials and workmanship
Comment:	The system satisfies the requirements of this Regulation. See the tinted area in the <i>Maintenance</i> and <i>Durability</i> sections (12.1, 12.2 and 13.1 to 13.3) and the <i>Installation</i> part of the accompanying Detail Sheet(s).
Regulation: 9	Building standards – construction
Standard: 2.9	Escape
Comment:	Windows providing an unobstructed openable area of at least 0.33 m ² and at least 450 mm high and 450 mm wide can satisfy this Standard, with reference to clause 2.9.4 ⁽¹⁾ as escape windows, when suitably located. The obstruction caused by opening lights hung on projecting friction stays must be taken into account when the clear opening is determined. However, the route through the window may be at an angle rather than straight through. Locks may be used but must not cause a permanent obstruction to satisfy clause 2.9.4 ⁽¹⁾ as escape windows.
Standard: 3.10	Precipitation
Comment:	Walls incorporating the system, installed and used in accordance with the provisions of this Certificate, can satisfy this Standard, with reference to clause 3.10.1 ⁽¹⁾⁽²⁾ . See Table 3 in the <i>Design Data</i> part of the accompanying Detail Sheet(s).
Standard: 3.14	Ventilation
Comment:	In calculating the contribution of the system to natural ventilation, with reference to clauses 3.14.2 ⁽²⁾ and 3.14.3 ⁽¹⁾ to this Standard, the area of opening can be calculated in accordance with the <i>Ventilation</i> section (6.1) of the accompanying Detail Sheet(s). Trickle ventilation, with reference to clauses 3.14.3 ⁽²⁾ and 3.14.5 ⁽¹⁾ , can be provided as described in the tinted area of the <i>Ventilation</i> section (6.2) of the accompanying Detail Sheet(s).
Standard: 3.15	Condensation
Comment:	The system can contribute to satisfying this Standard, with reference to clause 3.15.3 ⁽¹⁾ . See the tinted area in the <i>Condensation risk</i> section (8) of the accompanying Detail Sheet(s).
Standard: 3.16	Natural lighting
Comment:	In calculating the contribution of the system to natural lighting, with reference to clause 3.16.1 ⁽¹⁾ to this Standard, the area of glazing can be calculated in accordance with the <i>Glass area</i> section (5) of the accompanying Detail Sheet(s).

Standard:	4.8(b)(c)	Danger from accidents
Comment:		Glazing must comply with BS 6262-4 : 2005 where accidental collision with it is likely, in order to satisfy this Standard, with reference to clause 4.8.2 ⁽¹⁾⁽²⁾ . See the relevant tinted area in the <i>Safety</i> section (9.3) of the accompanying Detail Sheet(s). The provisions described in clauses 4.8.3 ⁽¹⁾⁽²⁾ and 4.8.4 ⁽¹⁾⁽²⁾ to this Standard, regarding the safe cleaning of windows, must also be taken into account.
Standard:	6.1(a)(b)	Carbon dioxide emissions
Standard:	6.2	Building insulation envelope
Comment:		In satisfying these Standards, with reference to clauses 6.1.3 ⁽¹⁾⁽²⁾ , 6.2.1 ⁽¹⁾⁽²⁾ , 6.2.2 ⁽¹⁾⁽²⁾ , 6.2.3 ⁽¹⁾⁽²⁾ , 6.2.7 ⁽¹⁾ , 6.2.8 ⁽²⁾ , 6.2.9 ⁽¹⁾ and 6.2.10 ⁽²⁾ , the U values given in the tinted area of the <i>Thermal insulation</i> section (7.1 and 7.2) of the accompanying Detail Sheet(s) should be used. For glazing other than that described in the Detail Sheet(s) indicative U values shown in Table 6e of SAP 2005, <i>The Government's Standard Assessment Procedure for Energy Rating of Dwellings</i> can be used. However, when available, a certified U value should be used in preference to the tabulated data.
Regulation:	12	Building standards – conversions
Comment:		All comments given for this product under Regulation 9, also apply to this Regulation, with reference to clause 0.12.1 ⁽¹⁾⁽²⁾ and Schedule 6 ⁽¹⁾⁽²⁾ . (1) Technical Handbook (Domestic). (2) Technical Handbook (Non-Domestic).

3 The Building Regulations (Northern Ireland) 2000 (as amended)



In the opinion of the BBA, the PVC-U Window System specified on the Front Sheet, if used in accordance with the provisions of this Certificate, will satisfy or contribute to satisfying the various Building Regulations as listed below.

Regulation:	B2	Fitness of materials and workmanship
Comment:		The system is acceptable. See the tinted areas in the <i>Durability</i> section (13.1 to 13.3) and the <i>Installation</i> part of the accompanying Detail Sheet(s).
Regulation:	B3(2)	Suitability of certain materials
Comment:		The system is acceptable. See the tinted areas in the <i>Maintenance</i> section (12.1 and 12.2) of the accompanying Detail Sheet(s).
Regulation:	C4(b)	Resistance to ground moisture and weather
Comment:		The windows are weathertight [see Table 3 in the <i>Design Data</i> part of the accompanying Detail Sheet(s)] and can thus contribute to the ability of the wall to meet this Regulation.
Regulation:	E2(c)	Means of escape
Comment:		Where a window is required in a dwelling house, to provide a means of escape from an inner room or a loft space converted into a habitable room, the window can meet this Requirement when it incorporates an opening light providing a clear opening area of at least 0.33 m ² and not less than 450 mm high by 450 mm wide and is positioned as set out in Technical Booklet E, Section 1. The obstruction caused by opening lights hung on projecting friction stays must be taken into account when the clear opening is determined.
Regulation:	F2(a)(i)	Conservation measures
Regulation:	F3	Target carbon dioxide Emissions Rate
Comment:		In satisfying these Regulations, the U values given in the tinted areas in the <i>Thermal insulation</i> section (7.3) of the accompanying Detail Sheet(s) should be used. For glazing other than that described in the accompanying Detail Sheet(s), the indicative U values shown in Table 6e of SAP 2005, <i>The Government's Standard Assessment Procedure for Energy Rating of Dwellings</i> can be used. When available, a certified U value by measurement or calculation, in accordance with the relevant Standards, should be used. In replacement work, an average elemental U value of 2.0 Wm ⁻² K ⁻¹ (dwellings) or 2.2 Wm ⁻² K ⁻¹ (buildings other than dwellings) is required for PVC-U windows. This can be met by the use of 4/16/4 mm double-glazed units with a low-E coating of emissivity 0.15 or better. Alternatively, a window with a window energy rating of Band E for replacement work is acceptable. New windows in extensions

Regulation:	H7	require a U value of $1.8 \text{ Wm}^{-2}\text{K}^{-1}$ or a window energy rating of Band D.
Comment:		Protection from collision with open windows, skylights or ventilators Reasonable provision shall be made to minimise the risk of people colliding with an open window when moving in or about a building. In so far as they relate to a dwelling, the requirements of this Regulation shall only apply to a window which opens over a public route of travel. The requirements of this Regulation shall be deemed to be satisfied if the window installation complies with Technical Booklet H, Section 7.
Regulation:	K2	Means of ventilation
Comment:		When calculating the area of window openings for ventilation purposes, see the relevant tinted area in the <i>Ventilation</i> section (6.1) of the accompanying Detail Sheet(s). Trickle ventilation can be provided by the methods described in the relevant tinted area in the <i>Ventilation</i> section (6.2) of the accompanying Detail Sheet(s).
Regulation:	V2	Impact with glazing
Comment:		Where people are likely to come into contact with glazing in a building the requirements of this Regulation shall be deemed to be satisfied if the glazing complies with Technical Booklet V, Section 2. See the relevant tinted area in the <i>Safety</i> section (9.3) of the accompanying Detail Sheet(s).
Regulation:	V3	Transparent glazing
Comment:		In a building, other than in a dwelling, transparent glazing, of which people may be unaware and with which they are likely to collide, shall incorporate features which make it apparent. The requirements of this Regulation shall be deemed to be satisfied if the glazing complies with Technical Booklet V, Section 3.
Regulation:	V4	Safe opening and closing of windows, skylights and ventilators
Comment:		Any window which can be opened by a person shall be so constructed or equipped that it may be opened, closed and adjusted safely. The requirements of this Regulation shall be deemed to be satisfied if the window complies with Technical Booklet V, Section 4. See the relevant tinted areas in the <i>Safety</i> section (9.1 and 9.2) of the accompanying Detail Sheet(s).
Regulation:	V5	Safe means of access for cleaning glazing
Comment:		Reasonable provision shall be made for safe means of access to clean glazing. The requirements of this Regulation shall be deemed to be satisfied if the means of access complies with Technical Booklet V, Section 5.

4 Construction (Design and Management) Regulations 2007

Construction (Design and Management) Regulations (Northern Ireland) 2007

Information in this Certificate may assist the client, CDM co-ordinator, designer and contractors to address their obligations under these Regulations.

See section: 2 Delivery and site handling of the accompanying Detail Sheet(s).



On behalf of the British Board of Agrément

Date of Eighteenth edition: 20 July 2009 Chris Hunt
Head of Approvals — Physics

Greg Cooper
Chief Executive

**THE VEKA MATRIX FS70
OUTWARD OPENING PVC-U WINDOW SYSTEM**

Product

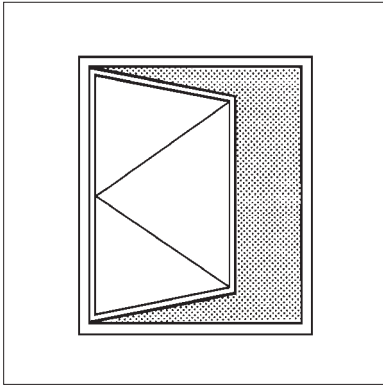

CAUTION: This Detail Sheet is not valid in isolation and must be read in conjunction with the Front Sheet and Detail Sheet 1, which give the Certificate holder's name, *Conditions of Certification*, and the product's position regarding the Building Regulations, respectively.

- *THIS DETAIL SHEET RELATES TO THE VEKA MATRIX FS70 OUTWARD OPENING PVC-U WINDOW SYSTEM.*
- *The system comprises single top-hung windows, single side-hung windows and multilight windows, comprising opening lights and fixed lights, all framed in white PVC-U and glazed internally with sealed double-glazed units⁽¹⁾.*
- *The product is for use where the test pressure classes defined in BS 6375-1 : 1989 and indicated in Table 3 are applicable.*
- *It is essential that the windows are installed and maintained in accordance with the conditions set out in the Design Data and Installation parts of this Detail Sheet.*

(1) *Outside the scope of this Certificate.*

Technical Specification

1 Description

1.1 The Veka Matrix FS70 outward opening windows (see Figure 1) are fabricated from white, unplasticized polyvinyl chloride (PVC-U) profiles, produced by conventional extrusion techniques from material complying with BS EN 12608 : 2003. The profiles covered by this Certificate (listed in Table 1 and shown in Figure 2) incorporate rolled-in gaskets made from TPE material, eliminating the need for separate assembly of weatherseals and glazing gaskets.

1.2 The methods of selection, machining and assembly of frame components are detailed in the *Veka Profile System Matrix FS70 Manual*

1.3 Multilight windows incorporate mullions and transoms connected to the outer frame and, where relevant, to each other by means of welded joints.

1.4 The PVC-U extrusions are cut to length, and all holes routed or drilled. Where required, galvanized steel reinforcement sections are inserted in the PVC-U sections before they are welded together. The welded connections are then cleaned up by polishing, knifing or using a purpose-made machine which also forms a groove or raised pyramid at the weld. The window is completed by securing the fittings in position with screws.

Figure 1 Corner detail

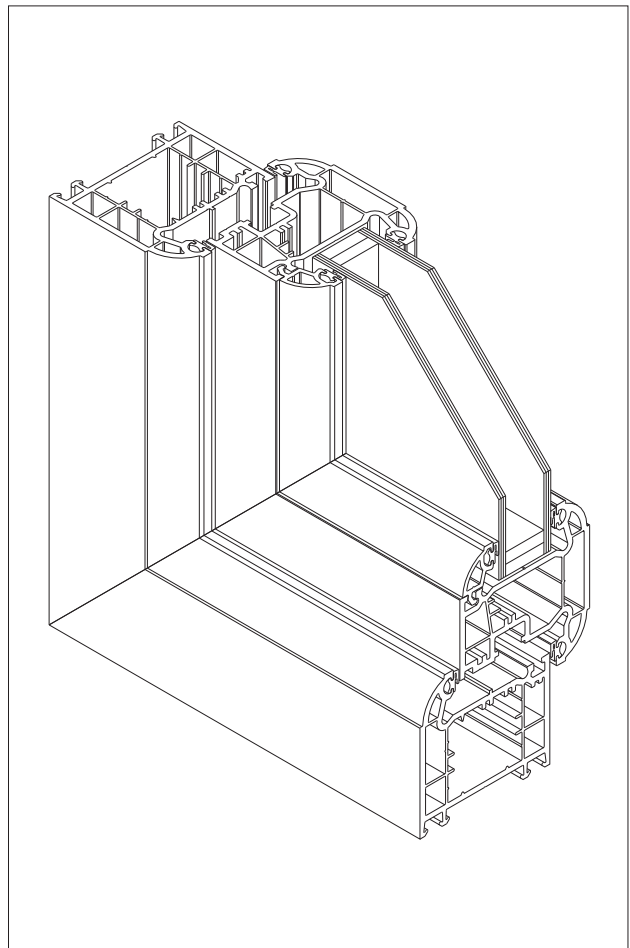

Table 1 Profiles

Manufacturer's designation	Profile type	Application
101.160 ⁽¹⁾	L-section	Outer frame (56 mm)
101.161 ⁽¹⁾	L-section	Outer frame (70 mm)
101.162 ⁽¹⁾	L-section	Outer frame (85 mm)
102.260 ⁽¹⁾	Z-section	Transom/mullion (64 mm)
102.261 ⁽¹⁾	T-section	Transom/mullion (64 mm)
102.262 ⁽¹⁾	Z-section	Transom/mullion (86 mm)
102.263 ⁽¹⁾	T-section	Transom/mullion (86 mm)
103.264 ⁽¹⁾	T-section	Sash
107.155	—	Glazing bead
109.265	—	cavity wedge
109.380	—	run up block
112.272	—	Rolled-in gasket
112.414	—	Glazing gasket (bead)
113.039	—	Galvanized steel reinforcement (103.264)
113.041	—	Galvanized steel reinforcement (102.260, 102.261)
113.245	—	Galvanized steel reinforcement (101.160)
113.317	—	Galvanized steel reinforcement (101.160)
113.372	—	Galvanized steel reinforcement (103.264)
113.378	—	Galvanized steel reinforcement (101.160, 101.161, 101.162, 102.262, 102.263)

(1) With rolled-in gaskets.

1.5 Drainage is provided by a series of slots, 5 mm by 30 mm, positioned in accordance with the *Veka Profile System Matrix FS70 Manual*. In general, on multilight units each element is treated as a separate window and drainage slots cut accordingly, to retain symmetry where possible.

Reinforcement

1.6 Outer frame members are not normally reinforced unless specifically required.

1.7 Top-hung opening light frame members are reinforced with galvanized mild steel where their length exceeds 1000 mm, in accordance with the *Veka Profile System Matrix FS70 Manual*. Side-hung opening light frame members are reinforced with galvanized mild steel where their width or height exceeds 700 mm and 1000 mm respectively in accordance with the *Veka Profile System Matrix FS70 Manual*.

1.8 Mullions and transoms are reinforced with galvanized mild steel where their length exceeds 600 mm, in accordance with the *Veka Profile System Matrix FS70 Manual*.

1.9 Galvanized steel reinforcement is roll-formed from material with a Z275N coating complying with BS EN 10346 : 2009.

Size range

1.10 This Detail Sheet covers Veka Matrix FS70 outward opening top-hung, side-hung and fixed-light windows and combinations of these within the limitations shown in Table 2.

Figure 2 Profiles (dimensions in mm)

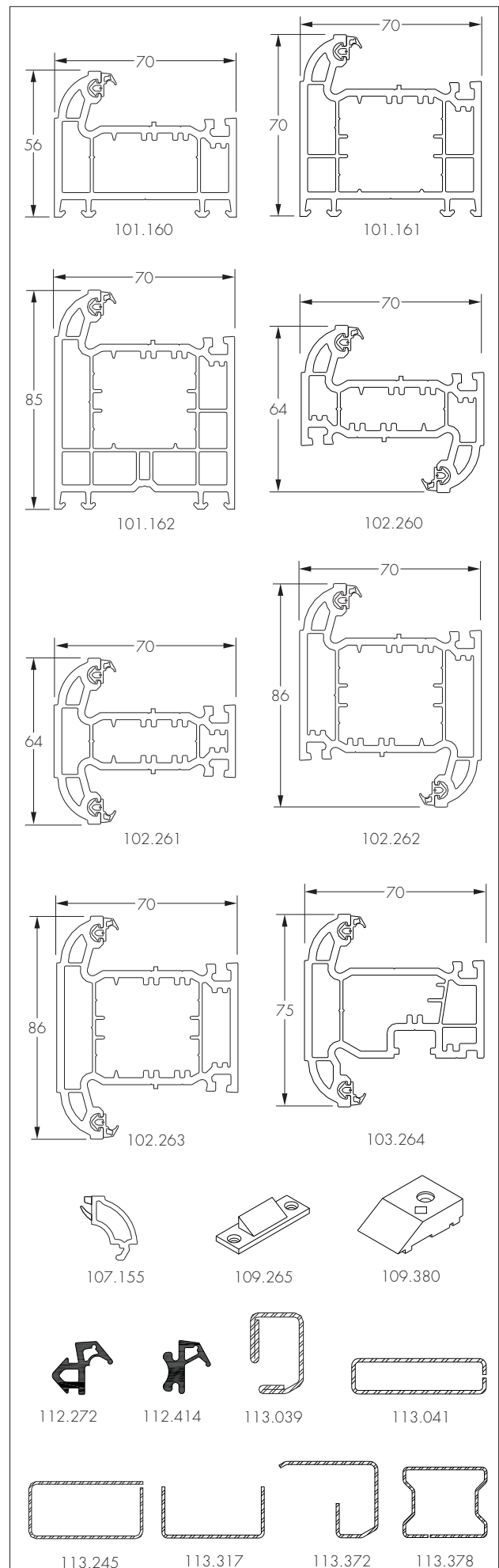

Table 2 Size restriction

	Dimension (mm)
<i>All windows</i>	
Maximum overall width or height of any outer frame	1500
Maximum length of mullions or transoms	1488
<i>Top-hung opening lights</i>	
Maximum size of top-hung opening light ⁽¹⁾ (reinforced, separately or in a multilight)	1257 wide x 1257 high
<i>Side-hung opening lights</i>	
Maximum size of side-hung opening light ⁽¹⁾ (reinforced, separately or in a multilight)	750 wide x 1357 high
<i>Fixed lights</i>	
Maximum size of fixed light (reinforced)	1500 wide x 1500 high

(1) Opening light sizes refer to outer frame to outer frame, or outer frame to mullion/transom centre line dimension, and must not exceed limitations on weight or size imposed by the friction hinge manufacturer.

Fittings

1.11 Top-hung and side-hung windows covered by this Detail Sheet are fitted with friction hinges constructed from stainless steel type 1.4016 to BS EN 10088-2 : 2005. The hinges incorporate a plastic slider which can be adjusted by means of a brass screw or a die-cast, slot-headed cam to provide the necessary braking action. The hinges are fixed to the frames with screws.

1.12 Opening windows are fastened by means of concealed espagnolette or shootbolt locking systems constructed from chromated zinc-plated mild steel, operated by a handle. Shootbolt and espagnolette handles are available, as an option, with a key locking facility. The keeps are made from zinc-based alloy or other materials approved by the BBA. The espagnolette and the keeps are fixed by means of self-tapping screws which penetrate a thickened area of the profile wall or the reinforcing. The espagnolette handle is formed from zinc-based alloy with various finishes.

1.13 Details of currently approved types of hinges and locking mechanisms can be obtained from the BBA. Additional components are available from the range of fittings to restrict the opening of the window to a maximum distance of 100 mm.

Glazing

1.14 Windows are supplied factory glazed or ready for glazing using double-glazed units with glass thicknesses in accordance with BS 6262-1 : 2005. All glass is positioned by plastic setting blocks and packing pieces.

Weatherstripping and gaskets

1.15 Gaskets and weatherstripping are rolled-in onto the profiles (see Figure 2).

Quality control

1.16 Quality control includes checks on all materials and components, in particular:

PVC-U compound

- bulk density
- pourability

Extruded profiles

- dimensions
- colour
- heat reversion
- resistance to cold impact

Fabrication procedures

- extrusions and fittings (visual inspection)
- overall dimensions
- operation and opening of locking mechanisms
- strength of welded corners.

2 Delivery and site handling

2.1 The windows are delivered to site glazed or ready for glazing. For transportation they are suitably protected to avoid damage.

2.2 Each window has a label bearing the company's mark and may include the BBA identification mark incorporating the number of this Certificate.

2.3 The windows should be stored under cover in a clean area, on edge and suitably supported to avoid distortion or damage.

2.4 The weight of glazing can be calculated, where required for manual handling operations, by reference to the information contained in BS 952-1 : 1995. The weight of the unglazed frame, and its ease of handling, particularly by one person, must also be taken into account when planning site operations.

2.5 When selecting means of access, for example use of scaffolding, the safety of the operatives, the occupants, and the passers-by, during the period of installation, should be considered.

Design Data

3 General

3.1 Selected samples from The Veka Matrix FS70 Outward Opening PVC-U Window System were tested in accordance with BS 6375-1 : 1989 and BS 6375-2 : 1987. Assessment of the results shows that the products, within the range described in section 1.10, are suitable for use where the test pressure classes defined in BS 6375-1 : 1989 and indicated in Table 3 are applicable. The gradings are based on the assumption that the outer frame is supported on all four sides in accordance with the manufacturer's instructions.

3.2 For unusual building layouts, building shapes or ground topography, the designer will need to give particular consideration to the prevailing exposure conditions.

Table 3 Test pressure class

	BS 6375-1 Test pressure class (Pa)
<i>Strength and stability</i>	
Single opening lights (reinforced) up to a maximum size	1200
Fixed lights (reinforced) up to a maximum size	1200
<i>Multilight with maximum length mullions/transoms</i>	
1200 mm (reinforced 113.041) width up to a maximum of 1300 mm height up to a maximum of 1300 mm perimeter up to a maximum of 5000 mm	2400
1488 mm (reinforced 113.378) width up to a maximum of 1600 height up to a maximum of 1600 perimeter up to a maximum of 6176	1200
<i>Watertightness</i>	
Fixed lights	300
Top-hung and side-hung opening lights up to maximum size	300
Multilights up to maximum size	300
<i>Air permeability</i>	
All windows	600

4 Practicability of installation

4.1 Installation does not present undue difficulty when fitting the windows in openings in new or existing walls provided the installation instructions are followed.

4.2 In common with other types of window fitted to prepared openings, Veka Matrix FS70 windows must be correctly positioned in relation to vertical damp-proof courses to prevent water penetration to the internal reveal.

5 Glass area



The approximate unobstructed glass area of the windows is determined by deducting from the overall width and height the appropriate profile dimensions. For each applicable feature, for example, a fixed light would require twice the outer frame dimension to be deducted from the overall width and overall height. Typical dimensions are given in Table 4.

Table 4 Typical dimensions for determining unobstructed glass area

Window feature	Dimensions (mm)
Outer frame (101.160)	56.0
Outer frame and sash (101.160 and 103.264)	103.5
Mullion between two fixed lights (102.261)	64.0
Mullion between one fixed and one opening light (102.260 and 103.264)	111.5
Mullion between two opening lights (102.261 and 103.264)	159.0

6 Ventilation



6.1 The opening area for natural ventilation may be calculated by multiplying together the overall width and height dimensions of opening lights reduced by the amounts given in Table 5. For opening lights abutting a mullion or transom, the overall width or height of that element will be given as the dimension from the edge of the outer frame to the centre line of the mullion or transom or, where relevant, between centres of the mullion or transom.

6.2 The background ventilation requirements of the various building regulations can be met by the incorporation in the window of a suitably-sized trickle ventilator. The ventilator may be glazed in, fitted in a supplementary head member or fitted by another method approved by the BBA for use with the Veka Matrix FS70 system. Details of any such approved fitting methods can be obtained from the BBA. Details of ventilators covered by an Agrément Certificate can be found on the BBA website.

Table 5 Typical natural ventilation dimension reductions

Frame member	Deduction from width or height (mm)
Outer frame 101.160	56
Mullion or transom 102.261	32

7 Thermal insulation



7.1 Table 6e of SAP 2005 *The Government's Standard Assessment Procedure for Energy Rating of Dwellings* and Table 6.A.1 of Annex 6.A,⁽¹⁾⁽²⁾ of Technical Handbook, Section 6, of The Building (Scotland) Regulations 2004 provide indicative thermal transmittance values (U values) for windows. For a PVC-U window incorporating 4/16/4 mm double glazing with a low-E coating of emissivity (ϵ_n) = 0.15, an indicative U value of 2.0 Wm⁻²K⁻¹ may be used when demonstrating compliance with the requirements of Part L1B (England and Wales) for replacement windows.

7.2 The overall thermal insulation of the window will be dependent on the performance of the double-glazed units. For units other than those described above, the indicative U values shown in Table 6e of SAP 2005 *The Government's Standard Assessment Procedure for Energy Rating of Dwellings* and Table 6.A.1 of Annex 6.A,⁽¹⁾⁽²⁾ of Technical Handbook, Section 6, of The Building (Scotland) Regulations 2004 can be used. When available, a certified U value by measurement to BS EN ISO 12567-1 : 2000, or calculation to BS EN ISO 10077-1 : 2000 and BS EN ISO 10077-2 : 2003 should be used in preference to these data given in these tables. Alternatively, window energy ratings may be

available for specific frame and glazing combinations.

- (1) Technical Handbook (Domestic).
- (2) Technical Handbook (Non-Domestic).



7.3 An indicative thermal transmittance value (U value) of $3.0 \text{ Wm}^{-2}\text{K}^{-1}$, as shown in Table 1.1 of Technical Booklet F: December 1998 (as amended) (Northern Ireland), can be used for a PVC-U window fitted with a standard, sealed, double-glazed unit (12 mm air gap). Indicative values for other glazing combinations are also given in Table 1.1 of Technical Booklet F, in the absence of certified data.

7.4 It is recommended that glazing units which meet the requirements of BS EN 1279-2 : 2002 and (if relevant) BS EN 1279-3 : 2002 are specified.

8 Condensation risk



Experience of PVC-U window systems similar to the Veka Matrix FS70 PVC-U window system has shown that, in normal domestic or similar applications, PVC-U windows do not constitute a significant condensation risk when correctly installed. Guidance on some satisfactory design details is given in *Limiting thermal bridging and air leakage : Robust construction details for dwellings and similar buildings* TSO 2002. Further information is contained in BRE report (BR 262 : 2002) *Thermal insulation : avoiding risks*.

9 Safety



9.1 When fitted with a restrictor, movement of the opening light can be effectively limited to give an opening of not more than 100 mm, as recommended for child safety in BS 8213-1 : 2004.

9.2 The windows can comply with the recommendations of BS 8213-1 : 2004 with regard to the positioning of hand-operated controls.



9.3 Account must be taken of the recommendations given in BS 6262-4 : 2005⁽¹⁾, which include the use of safety glass, complying with BS EN 12600 : 2002 or BS 6206 : 1981, under certain circumstances.

- (1) Dealing with the safety of people upon impact with the glazing.

10 Security against intrusion

10.1 Veka Matrix FS70 opening lights are fitted with a lock mechanism as described in section 1.12. When fastened in the closed position the opening light cannot be opened by manipulation from the outside, for example, by the insertion of a thin blade. Key operated locks are required for certain windows to meet the security requirements of NHBC Standards Chapter 6.7 *Doors, windows and glazing* and the *Zurich Building Guarantee*

Technical Manual, Section 5 Internal/external works, services and finishes, Sub-section External works — Security (page 167). It is vital that glass packing is carried out to the manufacturer's recommendations to prevent forced entry by flexing of the frame members allowing disengagement of the lock mechanism.

10.2 The design of the glazing is such that the removal of the glazing from outside is extremely difficult, as all beads are fitted internally.

11 Ease of operation

The window can be operated without difficulty when correctly installed.

12 Maintenance



12.1 The window can be re-glazed and gaskets and weatherstripping replaced, but these operations should be carried out by specialist operators using the materials recommended by the Certificate holder and approved by the BBA.

12.2 If damage occurs, the furniture and fittings can be replaced.

12.3 The PVC-U frame members can be cleaned using water containing household detergent. If dirt is allowed to build up on the members over long periods it may become more difficult to restore the surface appearance.

12.4 Care should be taken when using proprietary materials for cleaning the glass, to ensure that deposits are not allowed to remain on the PVC-U where they may cause discoloration and damage to the surface. In addition, care must be taken to avoid damage to, or discoloration of, the members when stripping paint from adjacent timber, for example, by means of a blowlamp or paint stripper.

12.5 Paints can adversely affect the impact strength of the PVC-U frame members and the application of dark colours to white profiles could lead to a risk of thermal distortion. Therefore painting is not recommended.

12.6 The friction hinges and locking mechanism should be cleaned and lubricated periodically to minimise wear and to ensure smooth operation. Care should be taken to avoid applying lubricant to the sliders as this will impair their braking action. The resistance of the sliders can be adjusted, if necessary, with the brass screw or die-cast, slot-headed cam provided in each slider.

13 Durability



13.1 Evidence is available on the performance in the UK of PVC-U similar to that used for the system over a period in excess of 20 years. Such evidence, when

compared with the results of tests on the Veka PVC-U, indicates that the windows will have a life of at least 25 years.

13.2 Fittings, including the hinges, locking mechanism and operating handles, as described in this Detail Sheet, will have similar durability except where windows are to be installed in areas subject to particularly aggressive conditions. These conditions can prevail in coastal locations or near sources of industrial pollutants and replacement of fittings may be necessary within the life of the window.

13.3 The rolled-in gaskets (see section 12.1) and the mastic seal to the building structure may need to be replaced within the life of the window.

13.4 Any slight colour change or surface dulling that might occur will be uniform over the visible surfaces of the windows.

Installation

14 General

14.1 The window must be fixed into the opening, in accordance with the recommendations in the British Plastic Federation's publication, 362/2 November 2004 *Code of Practice for the Survey & Installation of Windows and External Doorsets*, using proprietary expanding anchors through the frame or galvanized steel fixing lugs. Replacement windows should be fitted in accordance with BS 8213-4 : 2007 in particular with reference to Clause 8.7.

14.2 Openings in new walls should be formed using a suitable template 10 mm wider and higher than the window to be installed. The window should not be built in at the construction stage.

15 Procedure

Notwithstanding the information referred to in section 14.1, a typical installation involves the following steps:

- after checking the dimensions of the window, the frame is de-glazed if necessary and positioned in the opening. Holes are drilled through the outer frame and into the masonry to take fixing anchors. Alternatively, lugs are positioned on the frame and attached to the masonry by means of screws and plugs. In either case fixings must be positioned not less than 150 mm and not more than 250 mm from corners and at centres not exceeding 600 mm

- all glazing or re-glazing of the window is undertaken as required, using the technique fully described in the *Veka Profile System Matrix FS70 Manual*.
- the installation is completed by application of a silicone or similar durable sealant to the perimeter and the fitting of trims and window board to the interior.

Technical Investigations

The following is a summary of the technical investigations carried out on the Veka Matrix FS70 Outward Opening PVC-U Window System.

16 Tests

16.1 Tests were carried out in accordance with the methods defined in BS 6375-1 : 1989 and BS 6375-2 : 1987 to determine:

- air permeability
- watertightness
- effect of wind loads
- efficiency and durability of window fittings (eg cyclic operation and corrosion resistance)
- resistance to impact, racking and bending loads
- ease of operation.

16.2 Tests in accordance with MOAT No 8 : 1973, MOAT No 17 : 1990 and BS EN 12608 : 2003 gave the results for the PVC-U extrusions as detailed in Table 6.

Table 6 PVC-U extrusion test results

Test	Result
Ash content (%)	4.8
Vicat softening temperature (°C)	80.5
Tensile strength (MPa)	47.0
Modulus of elasticity (MPa)	2300
Tensile impact (kJm ⁻²)	
at 23°C	921
at 0°C	881
Induction time of dehydrochlorination (min)	
new material	61
UV aged material	49
Impact test at -10°C	pass
Shrinkage on heating at 100°C for 1 hour	<2%
Acetone resistance	pass

17 Investigations

The profile manufacturing process and the window fabrication procedure including, in each case, the methods adopted for quality control, have been examined and found satisfactory by the BBA.

Bibliography

BS 952-1 : 1995 *Glass for glazing — Classification*

BS 6206 : 1981 *Specification for impact performance requirements for flat safety glass and safety plastics for use in buildings*

BS 6262-1 : 2005 *Glazing for buildings — General methodology for the selection of glazing*

BS 6262-4 : 2005 *Glazing for buildings — Codes of practice for safety related to human impact*

BS 6375-1 : 1989 *Performance of windows — Classification for weathertightness (including guidance on selection and specification)*

BS 6375-2 : 1987 *Performance of windows — Specification for operation and strength characteristics*

BS 8213-1 : 2004 *Windows, doors and rooflights — Design for safety in use and during cleaning of windows, including door-height windows and roof windows — Code of practice*

BS 8213-4 : 2007 *Windows, doors and rooflights — Code of practice for the survey and installation of windows and external doorsets*

BS EN 10088-2 : 2005 *Stainless steels — Technical delivery conditions for sheet/plate and strip of corrosion resisting steels for general purposes*

BS EN 1279-2 : 2002 *Glass in building — Insulating glass units — Long term test method and requirements for moisture penetration*

BS EN 1279-3 : 2002 *Glass in building — Insulating glass units — Long term test method and requirements for gas leakage rate and for gas concentration tolerances*

BS EN 10346 : 2009 *Continuously hot-dip coated steel flat products — Technical delivery conditions*

BS EN 12600 : 2002 *Glass in building — Pendulum test — Impact test method and classification for flat glass*

BS EN 12608 : 2003 *Unplasticized polyvinylchloride (PVC-U) profiles for the fabrication of windows and doors — Classification, requirements and test methods*

BS EN ISO 10077-1 : 2000 *Thermal performance of windows, doors and shutters — Calculation of thermal transmittance — Part 1 : Simplified method*

BS EN ISO 10077-2 : 2003 *Thermal performance of windows, doors and shutters — Calculation of thermal transmittance — Part 2 : Numerical method for frames*

BS EN ISO 12567-1 : 2000 *Thermal performance of windows and doors — Determination of thermal transmittance by hot box method — Complete windows and doors*

MOAT No 8 : 1973 *Directive for Rigid PVC Products Used Externally in Building*

MOAT No 17 : 1990 *UEAtc Technical Guide for the Agrément of Windows in PVC-U*



On behalf of the British Board of Agrément

Date of First edition: 2nd December 2009

Head of Approvals
— Physics

Chief Executive

