

UCI SA

Zoning Industrial du Martinrou
B-6220 Fleurus
Belgium

Tel: 00 32 7187 05 40 Fax: 00 32 7187 05 41
e-mail: uci@uci.arcelor.com
website: www.arcelormittal.com



Agrément Certificate
10/4743
Product Sheet 1

INDUSWALL CLADDING PANELS

INDUSWALL INSULATED WALL CLADDING PANELS

PRODUCT SCOPE AND SUMMARY OF CERTIFICATE

This Certificate relates to Induswall Insulated Wall Cladding Panels, for use as a cladding for mechanical fixing to structural steel frames.

AGRÉMENT CERTIFICATION INCLUDES:

- factors relating to compliance with Building Regulations where applicable
- factors relating to additional non-regulatory information where applicable
- independently verified technical specification
- assessment criteria and technical investigations
- design considerations
- installation guidance
- regular surveillance of production
- formal three-yearly review.

KEY FACTORS ASSESSED

Structural performance — The panels have adequate strength to resist the loads associated with installation and service (see section 5).

Weathertightness — The product should be weathertight when used within the exposure conditions related to the design wind loads (see section 7).

Thermal insulation — The panels contribute to a construction meeting the requirements of the national Building Regulations (see section 8).

Condensation risk — The risk of condensation associated with the wall panels has been assessed (see section 10).



The BBA has awarded this Agrément Certificate to the company named above for the products described herein. These products have been assessed by the BBA as being fit for their intended use provided they are installed, used and maintained as set out in this Certificate.

On behalf of the British Board of Agrément

Date of First issue: 31 March 2010

Brian Chamberlain
Head of Approvals — Engineering

Greg Cooper
Chief Executive

The BBA is a UKAS accredited certification body — Number 1113. The schedule of the current scope of accreditation for product certification is available in pdf format via the UKAS link on the BBA website at www.bbacerts.co.uk

Readers are advised to check the validity and latest issue number of this Agrément Certificate by either referring to the BBA website or contacting the BBA direct.

British Board of Agrément
Bucknalls Lane
Garston, Watford
Herts WD25 9BA

©2010

tel: 01923 665300
fax: 01923 665301
e-mail: mail@bba.star.co.uk
website: www.bbacerts.co.uk

In the opinion of the BBA, Induswall Insulated Wall Cladding Panels, if used in accordance with the provisions of this Certificate, will meet or contribute to meeting the relevant requirements of the following Building Regulations:



The Building Regulations 2000 (as amended) (England and Wales)

Requirement: A1	Loading
Comment:	The product has sufficient strength and stiffness to sustain and transmit self weight and wind loads to the structural frame. See sections 5.1 to 5.6 of this Certificate.
Requirement: B2(1)	Internal fire spread (linings)
Comment:	The internal liner sheet has a Class 0 surface rating. See section 6.1 of this Certificate.
Requirement: B3(1)(2)(4)	Internal fire spread (structure)
Comment:	The product can meet this requirement. See section 6.3 of this Certificate.
Requirement: B4(1)	External fire spread
Comment:	The product has a Class 0 surface rating and can meet this Requirement. See section 6.1 of this Certificate.
Requirement: C2(b)	Resistance to moisture
Comment:	The product will resist the passage of moisture to the inside of the building. See sections 7.1 and 7.2 of this Certificate.
Requirement: C2(c)	Resistance to moisture
Comment:	The product will have a minimal risk of harmful effects on the building and people who use the building due to interstitial and surface condensation. See sections 10.3 to 10.5 of this Certificate.
Requirement: L1(a)(i)	Conservation of fuel and power
Comment:	The product can meet or contribute to meeting this Requirement. See sections 8.1 to 8.4 of this Certificate.
Requirement: Regulation 7	Materials and workmanship
Comment:	The product is acceptable. See section 12.1 and the <i>Installation</i> part of this Certificate.



The Building (Scotland) Regulations 2004 (as amended)

Regulation: 8(1)	Fitness and durability of materials and workmanship
Comment:	The use of the product satisfies the requirements of this Regulation. See sections 11.1, 11.5 and 12.1 and the <i>Installation</i> part of this Certificate.
Regulation: 9	Building standards — construction
Standard: 1.1(a)(b)	Structure
Comment:	The product has sufficient strength and stiffness to transmit self-weight and wind loads to the structural frame, with reference to clause 1.1.1 ⁽¹⁾⁽²⁾ of this Standard. See sections 5.1 to 5.6 of this Certificate.
Standard: 2.3	Structural protection
Comment:	The product can achieve a fire rating period of not less than short duration, with reference to clauses 2.3.2 ⁽¹⁾⁽²⁾ , 2.3.4 ⁽¹⁾⁽²⁾ and 2.3.5 ⁽¹⁾⁽²⁾ . See section 6.3 of this Certificate.
Standard: 2.5	Internal linings
Comment:	The product has a 'low risk' surface spread of flame rating and satisfies clause 2.5.1 ⁽¹⁾⁽²⁾ of this Standard. See section 6.1 of this Certificate.
Standard: 2.6	Spread to neighbouring buildings
Comment:	The product can achieve short duration, with reference to clause 2.6.1 ⁽¹⁾⁽²⁾ . See sections 6.1 and 6.2 of this Certificate.
Standard: 2.7	Spread on external walls
Comment:	The product has a 'low risk' surface rating, with reference to clause 2.7.1 ⁽¹⁾⁽²⁾ . See section 6.1 of this Certificate.
Standard: 3.10	Precipitation
Comment:	The product will resist the passage of moisture to the inside of the building, with reference to clause 3.10.5 ⁽¹⁾⁽²⁾ wall. See sections 7.1 and 7.2 of this Certificate.
Standard: 3.15	Condensation
Comment:	The risk of harmful effects on a dwelling due to interstitial condensation within the product will be minimal, with reference to clause 3.15.1 ⁽²⁾ . The product will have a minimal risk of harmful effects on the users of dwellings due to surface condensation. See sections 10.3 to 10.5 of this Certificate.
Standard: 6.2	Building insulation envelope
Comment:	The product will satisfy, or contribute to satisfying, clauses 6.2.1 ⁽¹⁾ , 6.2.4 ⁽¹⁾ and 6.2.5 ⁽¹⁾ of this Standard. See sections 8.1 to 8.4 of this Certificate.
	(1) Technical Handbook (Domestic).
	(2) Technical Handbook (Non-Domestic).



The Building Regulations (Northern Ireland) 2000 (as amended)

Regulation: B2	Fitness of materials and workmanship
Comment:	The product is acceptable. See section 12.1 and the <i>Installation</i> part of this Certificate.

Regulation:	B3(2)	Suitability of certain materials
Comment:		The product is acceptable. See sections 11.1 and 11.5 of this Certificate.
Regulation:	C4	Resistance to ground moisture and weather
Comment:		When subjected to the maximum design load, the product will resist the passage of moisture to the inside of the building. See sections 7.1 and 7.2 of this Certificate.
Regulation:	C5	Condensation
Comment:		The risk of harmful effects on dwellings due to interstitial condensation within the product will be minimal. See sections 10.3 to 10.5 of this Certificate.
Regulation:	D1	Stability
Comment:		The product has sufficient strength and stiffness to sustain and transmit self-weight and wind loads to the structural frame. See sections 5.1 to 5.6 of this Certificate.
Regulation:	E3	Internal fire spread – Linings
Comment:		The internal liner sheet has a Class 0 surface rating. See section 6.3 of this Certificate.
Regulation:	E4	Internal fire spread – Structure
Comment:		The product can satisfy this Regulation for walls one metre or more from a relevant boundary. See section 6.1 of this Certificate.
Regulation:	E5(a)	External fire spread
Comment:		The product has an Class 0 rating and can satisfy this Regulation. See section 6.1 of this Certificate.
Regulation:	F2(a)(i)	Conservation measures
Comment:		The product can satisfy or contribute to satisfying this Regulation. See sections 8.1 to 8.4 of this Certificate.

Construction (Design and Management) Regulations 2007

Construction (Design and Management) Regulations (Northern Ireland) 2007

Information in this Certificate may assist the client, CDM co-ordinator, designer and contractors to address their obligations under these Regulations.

See section: 2 Delivery and site handling (2.4) of this Certificate.

Non-regulatory Information

NHBC Standards 2007

NHBC accepts the use of Induswall Insulated Wall Cladding Panels, when installed and used in accordance with this Certificate, in relation to *NHBC Standards*, Chapter 6 *Superstructure (excluding roofs)*, section 6.9 *Curtain walling and cladding*.

General

This Certificate relates to Induswall Insulated Wall Cladding Panels, comprising profiled or plain, coated steel, internal and external sheets both bonded to a mineral wool core, installed horizontally between vertical structural members and/or vertically between horizontal rails.

The panels are for use as a cladding for mechanical fixing to structural steel frames.

The panels are weathertight, airtight and stable if constructed within the limits set out in this Certificate.

The panels are for use in retail, commercial and industrial wall applications.

Induswall is marketed in the UK under the name Promfire Through Fix.

Construction details shown in this Certificate have been included for illustrative purposes only and are not approved construction details.

Technical Specification

1 Description

1.1 Induswall Insulated Wall Cladding Panels comprise lamella manufactured from slabs of mineral wool insulation with a density of $100 \pm 15 \text{ kg}\cdot\text{m}^{-3}$, compression at 10% deformation of $>20 \text{ kPa}$ and tensile strength perpendicular to the face of $>10 \text{ kPa}$, adhesively bonded to an external smooth or profiled coated-steel sheet and an internal smooth or profiled coated-steel liner sheet (see Figure 1). The panels are fixed back to the structural frame using through fixings. The nominal mass/unit area of the panels is given in Table 1.

Table 1 Mass per unit area ($\text{kg}\cdot\text{m}^{-2}$)

Facing thickness (mm)		Nominal panel thickness (mm)				
Internal	External	60	80	100	120	150
0.50	0.63	15.5	17.7	19.2	21.2	24.3
0.50	0.75	16.5	18.7	20.2	22.2	25.3
0.63	0.63	16.6	18.8	20.3	22.3	25.4
0.63	0.75	17.6	19.8	21.3	23.3	26.4
0.75	0.75	18.6	20.8	22.3	24.3	27.4

1.2 The panels are available with the steel facings ribbed, grooved, micro-ribbed or smooth and in the specifications shown in Table 2.

Table 2 Panel specification

Steel type	Steel specification	Average panel thickness ⁽¹⁾ (mm)	Overall width (mm)	Usable width (mm)	Length (mm)
Galvanized ⁽²⁾⁽³⁾⁽⁴⁾	0.5 mm thick Grade S 350 and Z 275 in accordance with BS EN 10346 and BS EN 10143	60, 80, 100, 120 and 150	1018, 1218	1000, 1200 ± 2	2000–3000 ±5
					3000–15000 +5
					3000–15000 –10
Stainless ⁽²⁾⁽⁴⁾	0.5 or 0.63 mm thick Grade X2CrNi18-9 in accordance with BS EN 10088-2	60, 80, 100, 120 and 150	1018, 1218	1000, 1200 ± 2	2000–3000 ±5
					3000–15000 +5
	0.5 or 0.63 mm thick Grade X5CrNi Mo17-22-2 in accordance with BS EN 10088-2	60, 80, 100, 120 and 150	1018, 1218	1000, 1200 ± 2	2000–3000 ±5
					3000–15000 +5
				3000–15000 –10	

(1) Other thicknesses are available but are outside the scope of this Certificate. Further information can be obtained from the Certificate holder.

(2) Coated steel is supplied in accordance with BS EN 10169-2 : 2006.

(3) Other coatings must be covered by an appropriate Agrément Certificate.

(4) Steel must have a Class 0 surface (see section 6).

1.3 Panel lengths <2000 mm are manufactured by cutting larger panels. The tolerances of these panels are shown in Table 3.

Table 3 Cut panel tolerances

Measurement (mm)	Tolerance
≤1000	2 mm
≥1000	0.2%

1.4 The wall panels have male and female edges that interlock during installation (see Figure 1). The panels can be installed with or without vertical interlocking joints⁽¹⁾.

(1) Further information can be obtained from the Certificate holder.

Figure 1 Induswall cladding panel

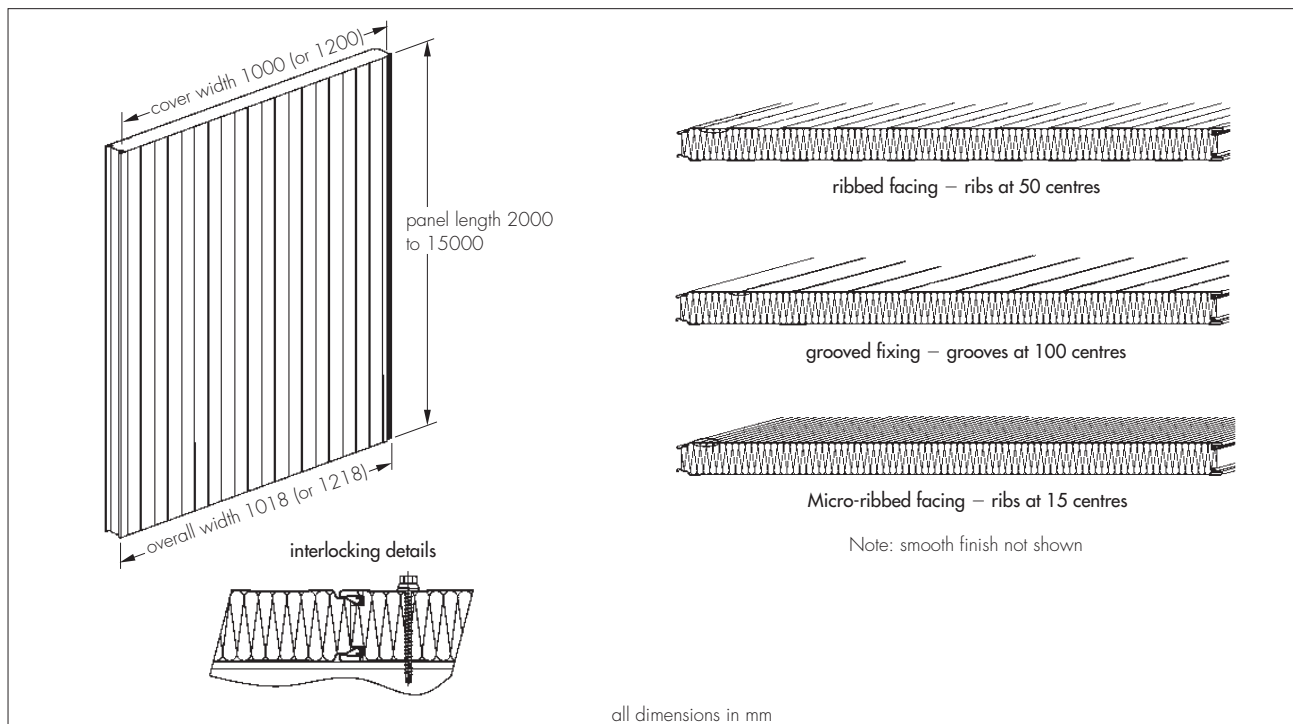

1.5 Ancillary items supplied by the Certificate holder are:

- shaped steel sealing plates, parapet copings, interior and exterior corners, joint trims, drip flashings, corner flashings and frame supports (adjustable steel support framework angles and panel bearers) fabricated from the steel of the same specification to the panel but with a standard thickness of ≥ 0.70 mm. In special cases, for example where continuity of appearance or colour tone is required, these can be fabricated from the same batch of steel used for the panels.

1.6 Items not supplied by the Certificate holder that form part of the wall panel once the construction has been completed include:

- silicone and butyl sealants
- preformed butyl strip with adhesive
- expanding polyurethane foam
- flexible foam joints
- 5.5 mm diameter, steel, self-drilling screws for anchoring to steel (see section 13.5)
- 6.3 mm diameter, steel, self-drilling screws for anchoring to wood (see section 13.5)
- 6.3 mm diameter, steel, self-tapping screws
- minimum 8 mm diameter, anchor bolts
- minimum 19 mm diameter, sealing washers
- stainless steel rivets shank A2 — stem 10% Cr, for fastening shaped accessories.

1.7 Windows and doors used with the panels are outside the scope of this Certificate.

2 Delivery and site handling

2.1 The wall panels are delivered to site in packs of the required length wrapped in plastic, each carrying a label bearing the manufacturer's name, customer order reference, customer name, date of manufacture, panel type, thickness of mineral wool, skin thickness, weight of load, content of load, coating type, colour reference number and the BBA identification mark incorporating the number of this Certificate.

2.2 Each panel is coated with a protective film that must be removed no later than one month after the panel has been dispatched from the factory and at least ten days after the panel is installed.

2.3 The panels should not be stacked more than two packs high; storage on site should be kept to a minimum. If the panels are not required immediately they should be stored off the ground on timber bearers at 2 m centres on firm level ground, away from sunlight and preferably under cover. Care must be taken to avoid the ingress of water into the panels.

2.4 Where panels cannot be stored in a building, they should be stored covered with a weatherproof sheet in a secure location on a slope to ensure that water can drain off, and should be arranged so that air is able to circulate around the panels.

2.5 The panels should be lifted using either a crane or a fork-lift, depending on the weight, length and orientation (whether the interlocking joints are horizontal or vertical). Lifting beams (spreader bar with flat slings) must be used on panels over 6 m in length, with panel edges being protected during lifting. The Certificate holder's instructions should be followed when lifting panels.

2.6 To protect the surface coatings, especially around the edges, individual panels should never be dragged over other panels.

2.7 The durability of the wall panels will depend on the panel and other components being undamaged before (and not damaged during) installation, therefore, the handling and storage of these items should be in accordance with the above details.

Assessment and Technical Investigations

The following is a summary of the assessment and technical investigations carried out on the Induswall Insulated Wall Cladding Panels.

Design considerations

3 General

3.1 Induswall Insulated Wall Cladding Panels are satisfactory for use when installed onto a supporting structural frame and fixed at appropriate centres.

3.2 The minimum dimensions and position of the supporting frame are:

- minimum thickness for the steel framework is 1.5 mm
- support width of at least 30 mm at the panel ends, and 40 mm for the intermediate supports
- the distance between the edge of the panel and the fixing should be between 20 mm and 600 mm
- maximum overhang 600 mm
- edge support at joints (eg corners)
- steel frames must have a minimum thickness of 1.5 mm at supports to ensure there is adequate anchorage for the fixings
- wooden frames must have a minimum cross-section of 80 mm by 80 mm
- concrete or masonry must incorporate a continuous support in the form of an anchored steel profile at least 60 mm wide with a thickness of 2.5 mm at supports.

4 Practicability of installation

The panels should only be installed by installers who have been trained and approved by the Certificate holder (see section 13).

5 Structural performance



5.1 The design of the supporting frame is the responsibility of the building designer (see section 14).

5.2 The wall panels are able to support their own weight and the cladding can be designed to resist any wind loads that are likely in the UK, however they are not loadbearing and must be installed onto a supporting structural frame. It is essential that the instructions given in the Certificate holder's handling guide is followed.

5.3 The wall panels have adequate strength and stiffness to sustain specified loads when used in accordance with this Certificate.

5.4 When evaluating the design loads, the wind loads must be calculated in accordance with the recommendations of BS 6399-2 : 1997.

5.5 Load-span values are given in Tables 4 to 13.

5.6 In these tables, the maximum distance between frame elements (based on testing) is determined on the basis of the following criteria (after the calculation of pressure loadings under normal wind conditions):

- allowable mid-span deflection $\leq 1/200$ of the span
- safety factor of 3
- pull-out strength of fastenings (see section 58)

Table 4 Working loads under suction ($kN \cdot m^{-2}$) — Panel: 1 m wide, 60 mm thick

Span (m)	Two supports						Pressure ($kN \cdot m^{-2}$)	Three supports						Pressure ($kN \cdot m^{-2}$)
	Thickness of exterior facing (mm)							Thickness of exterior facing (mm)						
	0.5			0.63				0.5			0.63			
	No of fixings per support			No of fixings per support				No of fixings per support			No of fixings per support			
	3	4	5	3	4	5		3	4	5	3	4	5	
1.30	-	-	-	-	-	-	-	1.38	1.76	1.76	1.76	1.76	1.76	1.85
1.40	-	-	-	-	-	-	-	1.29	1.61	1.61	1.61	1.61	1.61	1.71
1.50	-	-	-	-	-	-	-	1.20	1.48	1.48	1.48	1.48	1.48	1.59
1.60	-	-	-	-	-	-	-	1.13	1.37	1.37	1.37	1.37	1.37	1.48
1.70	-	-	-	-	-	-	-	1.06	1.27	1.27	1.27	1.27	1.27	1.39
1.80	-	-	-	-	-	-	-	1.00	1.19	1.19	1.19	1.19	1.19	1.30
1.90	-	-	-	-	-	-	-	0.95	1.12	1.12	1.12	1.12	1.12	1.23
2.00	-	-	-	-	-	-	-	0.90	1.05	1.05	1.05	1.05	1.05	1.16
2.10	1.20	1.20	1.20	1.20	1.20	1.20	1.44	0.86	0.99	0.99	0.99	0.99	0.99	1.11
2.20	1.15	1.15	1.15	1.15	1.15	1.15	1.36	0.82	0.94	0.94	0.94	0.94	0.94	1.05
2.30	1.11	1.11	1.11	1.11	1.11	1.11	1.29	0.78	0.90	0.90	0.90	0.90	0.90	1.00
2.40	1.07	1.07	1.07	1.07	1.07	1.07	1.22	0.75	0.85	0.85	0.85	0.85	0.85	0.96
2.50	1.03	1.03	1.03	1.03	1.03	1.03	1.16	0.72	0.82	0.82	0.82	0.82	0.82	0.92
2.60	0.99	0.99	0.99	0.99	0.99	0.99	1.10	0.69	0.77	0.77	0.77	0.77	0.77	0.87
2.70	0.96	0.96	0.96	0.96	0.96	0.96	1.05	0.67	0.73	0.73	0.73	0.73	0.73	0.83
2.80	0.93	0.93	0.93	0.93	0.93	0.93	1.01	0.64	0.70	0.70	0.70	0.70	0.70	0.79
2.90	0.89	0.89	0.89	0.89	0.89	0.89	0.95	0.62	0.67	0.67	0.67	0.67	0.67	0.76
3.00	0.86	0.86	0.86	0.86	0.86	0.86	0.90	0.60	0.64	0.64	0.64	0.64	0.64	0.73
3.10	0.84	0.84	0.84	0.84	0.84	0.84	0.85	0.58	0.61	0.61	0.61	0.61	0.61	0.70
3.20	0.81	0.81	0.81	0.81	0.81	0.81	0.80	0.56	0.59	0.59	0.59	0.59	0.59	0.67
3.30	0.79	0.79	0.79	0.79	0.79	0.79	0.76	0.55	0.56	0.56	0.56	0.56	0.56	0.65
3.40	0.76	0.76	0.76	0.76	0.76	0.76	0.73	0.53	0.54	0.54	0.54	0.54	0.54	0.62
3.50	0.74	0.74	0.74	0.74	0.74	0.74	0.69	0.51	0.52	0.52	0.52	0.52	0.52	0.60

Table 5 Working loads in suction ($kN \cdot m^{-2}$) — Panel: 1.2 m wide, 60 mm thick

Span (m)	Two supports						Pressure ($kN \cdot m^{-2}$)	Three supports						Pressure ($kN \cdot m^{-2}$)
	Thickness of exterior facing (mm)							Thickness of exterior facing (mm)						
	0.5			0.63				0.5			0.63			
	No of fixings per support			No of fixings per support				No of fixings per support			No of fixings per support			
	3	4	5	3	4	5		3	4	5	3	4	5	
1.30	-	-	-	-	-	-	-	1.15	1.54	1.76	1.76	1.76	1.76	1.85
1.40	-	-	-	-	-	-	-	1.07	1.43	1.61	1.61	1.61	1.61	1.71
1.50	-	-	-	-	-	-	-	1.00	1.33	1.48	1.48	1.48	1.48	1.59
1.60	-	-	-	-	-	-	-	0.94	1.25	1.37	1.37	1.37	1.37	1.48
1.70	-	-	-	-	-	-	-	0.88	1.18	1.27	1.27	1.27	1.27	1.39
1.80	-	-	-	-	-	-	-	0.83	1.11	1.19	1.19	1.19	1.19	1.30
1.90	-	-	-	-	-	-	-	0.79	1.05	1.12	1.12	1.12	1.12	1.23
2.00	-	-	-	-	-	-	-	0.75	1.00	1.05	1.05	1.05	1.05	1.16
2.10	1.20	1.20	1.20	1.20	1.20	1.20	1.44	0.71	0.95	0.99	0.99	0.99	0.99	1.11
2.20	1.15	1.15	1.15	1.15	1.15	1.15	1.36	0.68	0.91	0.94	0.94	0.94	0.94	1.05
2.30	1.11	1.11	1.11	1.11	1.11	1.11	1.29	0.65	0.87	0.90	0.90	0.90	0.90	1.00
2.40	1.07	1.07	1.07	1.07	1.07	1.07	1.22	0.63	0.83	0.85	0.85	0.85	0.85	0.96
2.50	1.03	1.03	1.03	1.03	1.03	1.03	1.16	0.60	0.80	0.82	0.82	0.82	0.82	0.92
2.60	0.99	0.99	0.99	0.99	0.99	0.99	1.10	0.58	0.77	0.77	0.77	0.77	0.77	0.87
2.70	0.96	0.96	0.96	0.96	0.96	0.96	1.05	0.56	0.73	0.73	0.73	0.73	0.73	0.83
2.80	0.93	0.93	0.93	0.93	0.93	0.93	1.01	0.54	0.70	0.70	0.70	0.70	0.70	0.79
2.90	0.89	0.89	0.89	0.89	0.89	0.89	0.95	0.52	0.67	0.67	0.67	0.67	0.67	0.76
3.00	0.86	0.86	0.86	0.86	0.86	0.86	0.90	0.50	0.64	0.64	0.64	0.64	0.64	0.73
3.10	0.84	0.84	0.84	0.84	0.84	0.84	0.85	0.48	0.61	0.61	0.61	0.61	0.61	0.70
3.20	0.81	0.81	0.81	0.81	0.81	0.81	0.80	0.47	0.59	0.59	0.59	0.59	0.59	0.67
3.30	0.79	0.79	0.79	0.79	0.79	0.79	0.76	0.45	0.56	0.56	0.56	0.56	0.56	0.65
3.40	0.76	0.76	0.76	0.76	0.76	0.76	0.73	0.44	0.54	0.54	0.54	0.54	0.54	0.62
3.50	0.74	0.74	0.74	0.74	0.74	0.74	0.69	0.43	0.52	0.52	0.52	0.52	0.52	0.60

Table 6 Working loads in suction ($kN\cdot m^{-2}$) – Panel: 1 m wide, 80 mm thick

Span (m)	Two supports							Three supports						
	Thickness of exterior facing (mm)						Pressure ($kN\cdot m^{-2}$)	Thickness of exterior facing (mm)						Pressure ($kN\cdot m^{-2}$)
	0.5			0.63				0.5			0.63			
No of fixings per support			No of fixings per support			3	No of fixings per support			No of fixings per support			3	
3	4	5	3	4	5		3	4	5	3	4	5		
1.80	–	–	–	–	–	–	–	1.00	1.33	1.58	1.58	1.58	1.58	1.83
1.90	–	–	–	–	–	–	–	0.95	1.26	1.48	1.48	1.48	1.48	1.71
2.00	–	–	–	–	–	–	–	0.90	1.20	1.39	1.39	1.39	1.39	1.60
2.10	1.75	1.75	1.75	1.75	1.75	1.75	1.73	0.86	1.14	1.31	1.31	1.31	1.31	1.51
2.20	1.67	1.67	1.67	1.67	1.67	1.67	1.64	0.82	1.09	1.24	1.24	1.24	1.24	1.42
2.30	1.60	1.60	1.60	1.60	1.60	1.60	1.55	0.78	1.04	1.18	1.18	1.18	1.18	1.34
2.40	1.53	1.53	1.53	1.53	1.53	1.53	1.47	0.75	1.00	1.12	1.12	1.12	1.12	1.21
2.50	1.47	1.47	1.47	1.47	1.47	1.47	1.40	0.72	0.96	1.07	1.07	1.07	1.07	1.16
2.60	1.42	1.42	1.42	1.42	1.42	1.42	1.34	0.69	0.92	1.02	1.02	1.02	1.02	1.15
2.70	1.36	1.36	1.36	1.36	1.36	1.36	1.28	0.67	0.89	0.97	0.97	0.97	0.97	1.09
2.80	1.31	1.31	1.31	1.31	1.31	1.31	1.23	0.64	0.86	0.93	0.93	0.93	0.93	1.04
2.90	1.27	1.27	1.27	1.27	1.27	1.27	1.17	0.62	0.83	0.89	0.89	0.89	0.89	1.00
3.00	1.22	1.22	1.22	1.22	1.22	1.22	1.11	0.60	0.80	0.85	0.85	0.85	0.85	0.95
3.10	1.18	1.18	1.18	1.18	1.18	1.18	1.07	0.58	0.77	0.82	0.82	0.82	0.82	0.92
3.20	1.15	1.15	1.15	1.15	1.15	1.15	1.02	0.56	0.75	0.78	0.78	0.78	0.78	0.88
3.30	1.11	1.11	1.11	1.11	1.11	1.11	0.98	0.55	0.73	0.76	0.76	0.76	0.76	0.84
3.40	1.08	1.08	1.08	1.08	1.08	1.08	0.94	0.53	0.71	0.73	0.73	0.73	0.73	0.81
3.50	1.05	1.05	1.05	1.05	1.05	1.05	0.91	0.51	0.69	0.70	0.70	0.70	0.70	0.78

Table 7 Working loads in suction ($kN\cdot m^{-2}$) – Panel: 1.2 m wide, 80 mm thick

Span (m)	Two supports							Three supports						
	Thickness of exterior facing (mm)						Pressure ($kN\cdot m^{-2}$)	Thickness of exterior facing (mm)						Pressure ($kN\cdot m^{-2}$)
	0.5			0.63				0.5			0.63			
No of fixings per support			No of fixings per support			3	No of fixings per support			No of fixings per support			3	
3	4	5	3	4	5		3	4	5	3	4	5		
1.80	–	–	–	–	–	–	–	0.83	1.11	1.39	1.58	1.58	1.58	1.83
1.90	–	–	–	–	–	–	–	0.79	1.05	1.32	1.48	1.48	1.48	1.71
2.00	–	–	–	–	–	–	–	0.75	1.00	1.25	1.39	1.39	1.39	1.60
2.10	1.75	1.75	1.75	1.75	1.75	1.75	1.73	0.71	0.95	1.19	1.31	1.31	1.31	1.51
2.20	1.67	1.67	1.67	1.67	1.67	1.67	1.64	0.68	0.91	1.14	1.24	1.24	1.24	1.42
2.30	1.60	1.60	1.60	1.60	1.60	1.60	1.55	0.65	0.87	1.09	1.18	1.18	1.18	1.34
2.40	1.53	1.53	1.53	1.53	1.53	1.53	1.47	0.63	0.83	1.04	1.12	1.12	1.12	1.27
2.50	1.47	1.47	1.47	1.47	1.47	1.47	1.40	0.60	0.80	1.00	1.07	1.07	1.07	1.21
2.60	1.42	1.42	1.42	1.42	1.42	1.42	1.34	0.58	0.77	0.96	1.02	1.02	1.02	1.15
2.70	1.36	1.36	1.36	1.36	1.36	1.36	1.28	0.56	0.74	0.93	0.97	0.97	0.97	1.09
2.80	1.31	1.31	1.31	1.31	1.31	1.31	1.23	0.54	0.71	0.89	0.93	0.93	0.93	1.04
2.90	1.27	1.27	1.27	1.27	1.27	1.27	1.17	0.52	0.69	0.86	0.89	0.89	0.89	1.00
3.00	1.22	1.22	1.22	1.22	1.22	1.22	1.11	0.50	0.67	0.83	0.85	0.85	0.85	0.95
3.10	1.18	1.18	1.18	1.18	1.18	1.18	1.07	0.48	0.65	0.81	0.82	0.82	0.82	0.92
3.20	1.15	1.15	1.15	1.15	1.15	1.15	1.02	0.47	0.63	0.78	0.78	0.78	0.78	0.88
3.30	1.11	1.11	1.11	1.11	1.11	1.11	0.98	0.45	0.61	0.76	0.76	0.76	0.76	0.84
3.40	1.08	1.08	1.08	1.08	1.08	1.08	0.94	0.44	0.59	0.73	0.73	0.73	0.73	0.81
3.50	1.05	1.05	1.05	1.05	1.05	1.05	0.91	0.43	0.57	0.70	0.70	0.70	0.70	0.78

Table 8 Working loads in suction ($kN\cdot m^{-2}$) – Panel: 1 m wide, 100 mm thick

Span (m)	Two supports							Three supports						
	Thickness of exterior facing (mm)						Pressure ($kN\cdot m^{-2}$)	Thickness of exterior facing (mm)						Pressure ($kN\cdot m^{-2}$)
	0.5			0.63				0.5			0.63			
No of fixings per support			No of fixings per support			3	No of fixings per support			No of fixings per support			3	
3	4	5	3	4	5		3	4	5	3	4	5		
1.80	–	–	–	–	–	–	–	1.00	1.33	1.67	1.98	1.98	1.98	2.36
1.90	–	–	–	–	–	–	–	0.95	1.26	1.58	1.85	1.85	1.85	2.19
2.00	–	–	–	–	–	–	–	0.90	1.20	1.50	1.73	1.73	1.73	2.04
2.10	2.14	2.31	2.31	2.31	2.31	2.31	2.02	0.86	1.14	1.43	1.63	1.63	1.63	1.91
2.20	2.05	2.19	2.19	2.19	2.19	2.19	1.91	0.82	1.09	1.36	1.54	1.54	1.54	1.79
2.30	1.96	2.09	2.09	2.09	2.09	2.09	1.81	0.78	1.04	1.30	1.46	1.46	1.46	1.68
2.40	1.88	2.00	2.00	2.00	2.00	2.00	1.72	0.75	1.00	1.25	1.39	1.39	1.39	1.59
2.50	1.80	1.92	1.92	1.92	1.92	1.92	1.64	0.72	0.96	1.20	1.32	1.32	1.32	1.50
2.60	1.73	1.84	1.84	1.84	1.84	1.84	1.57	0.69	0.92	1.15	1.26	1.26	1.26	1.43
2.70	1.67	1.77	1.77	1.77	1.77	1.77	1.50	0.67	0.89	1.11	1.20	1.20	1.20	1.36
2.80	1.61	1.70	1.70	1.70	1.70	1.70	1.44	0.64	0.86	1.07	1.15	1.15	1.15	1.29
2.90	1.55	1.64	1.64	1.64	1.64	1.64	1.39	0.62	0.83	1.03	1.10	1.10	1.10	1.23
3.00	1.50	1.58	1.58	1.58	1.58	1.58	1.33	0.60	0.80	1.00	1.06	1.06	1.06	1.18
3.10	1.45	1.53	1.53	1.53	1.53	1.53	1.28	0.58	0.77	0.97	1.02	1.02	1.02	1.13
3.20	1.41	1.48	1.48	1.48	1.48	1.48	1.24	0.56	0.75	0.94	0.98	0.98	0.98	1.09
3.30	1.36	1.43	1.43	1.43	1.43	1.43	1.20	0.55	0.73	0.91	0.95	0.95	0.95	1.04
3.40	1.32	1.39	1.39	1.39	1.39	1.39	1.16	0.53	0.71	0.88	0.92	0.92	0.92	1.01
3.50	1.29	1.35	1.35	1.35	1.35	1.35	1.12	0.51	0.69	0.86	0.89	0.89	0.89	0.97
3.60	1.25	1.31	1.31	1.31	1.31	1.31	1.08	0.50	0.67	0.83	0.86	0.86	0.86	0.93
3.70	1.22	1.27	1.27	1.27	1.27	1.27	1.05	0.49	0.65	0.81	0.83	0.83	0.83	0.90
3.80	1.18	1.24	1.24	1.24	1.24	1.24	1.02	0.47	0.63	0.79	0.81	0.81	0.81	0.87
3.90	1.15	1.21	1.21	1.21	1.21	1.21	0.99	0.46	0.62	0.77	0.79	0.79	0.79	0.86
4.00	1.13	1.18	1.18	1.18	1.18	1.18	0.96	0.45	0.60	0.75	0.78	0.78	0.78	0.84
4.10	1.10	1.12	1.12	1.12	1.12	1.12	0.93	0.44	0.59	0.73	0.77	0.77	0.77	0.82
4.20	1.07	1.07	1.07	1.07	1.07	1.07	0.89	0.43	0.57	0.71	0.76	0.76	0.76	0.81
4.30	1.02	1.02	1.02	1.02	1.02	1.02	0.86	0.42	0.56	0.70	0.75	0.75	0.75	0.79
4.40	0.98	0.98	0.98	0.98	0.98	0.98	0.83	0.41	0.55	0.68	0.74	0.74	0.74	0.78
4.50	0.94	0.94	0.94	0.94	0.94	0.94	0.80	0.40	0.53	0.67	0.72	0.72	0.72	0.77
4.60	0.90	0.90	0.90	0.90	0.90	0.90	0.78	0.39	0.52	0.65	0.71	0.71	0.71	0.75
4.70	0.86	0.86	0.86	0.86	0.86	0.86	0.75	0.38	0.51	0.64	0.70	0.70	0.70	0.74
4.80	0.83	0.83	0.83	0.83	0.83	0.83	0.73	0.38	0.50	0.63	0.69	0.69	0.69	0.73
4.90	0.80	0.80	0.80	0.80	0.80	0.80	0.71	0.37	0.49	0.61	0.68	0.68	0.68	0.72
5.00	0.77	0.77	0.77	0.77	0.77	0.77	0.68	0.36	0.48	0.60	0.67	0.67	0.67	0.70
5.10	0.74	0.74	0.74	0.74	0.74	0.74	0.66	0.35	0.47	0.59	0.66	0.66	0.66	0.69
5.20	0.71	0.71	0.71	0.71	0.71	0.71	0.65	0.35	0.46	0.58	0.65	0.65	0.65	0.68
5.30	0.69	0.69	0.69	0.69	0.69	0.69	0.63	0.34	0.45	0.57	0.65	0.65	0.65	0.67
5.40	0.66	0.66	0.66	0.66	0.66	0.66	0.61	0.33	0.44	0.56	0.64	0.64	0.64	0.66
5.50	0.64	0.64	0.64	0.64	0.64	0.64	0.59	0.33	0.44	0.55	0.63	0.63	0.63	0.65
5.60	0.62	0.62	0.62	0.62	0.62	0.62	0.58	0.32	0.43	0.54	0.62	0.62	0.62	0.64
5.70	0.60	0.60	0.60	0.60	0.60	0.60	0.56	0.32	0.42	0.53	0.61	0.61	0.61	0.63
5.80	0.58	0.58	0.58	0.58	0.58	0.58	0.55	0.31	0.41	0.52	0.60	0.60	0.60	0.62

Table 9 Working loads in suction ($kN \cdot m^{-2}$) – Panel: 1.2 m wide, 100 mm thick

Span (m)	Two supports							Three supports						
	Thickness of exterior facing (mm)						Pressure ($kN \cdot m^{-2}$)	Thickness of exterior facing (mm)						Pressure ($kN \cdot m^{-2}$)
	0.5			0.63				0.5			0.63			
No of fixings per support			No of fixings per support			No of fixings per support			No of fixings per support					
	3	4	5	3	4	5		3	4	5	3	4	5	
1.80	–	–	–	–	–	–	–	0.83	1.11	1.39	1.67	1.98	1.98	2.36
1.90	–	–	–	–	–	–	–	0.79	1.05	1.32	1.58	1.85	1.85	2.19
2.00	–	–	–	–	–	–	–	0.75	1.00	1.25	1.50	1.73	1.73	2.04
2.10	1.79	2.31	2.31	2.31	2.31	2.31	2.02	0.71	0.95	1.19	1.43	1.63	1.63	1.91
2.20	1.70	2.19	2.19	2.19	2.19	2.19	1.91	0.68	0.91	1.14	1.36	1.54	1.54	1.79
2.30	1.63	2.09	2.09	2.09	2.09	2.09	1.81	0.65	0.87	1.09	1.30	1.46	1.46	1.68
2.40	1.56	2.00	2.00	2.00	2.00	2.00	1.72	0.63	0.83	1.04	1.25	1.39	1.39	1.59
2.50	1.50	1.92	1.92	1.92	1.92	1.92	1.64	0.60	0.80	1.00	1.20	1.32	1.32	1.50
2.60	1.44	1.84	1.84	1.84	1.84	1.84	1.57	0.58	0.77	0.96	1.15	1.26	1.26	1.43
2.70	1.39	1.77	1.77	1.77	1.77	1.77	1.50	0.56	0.74	0.93	1.11	1.20	1.20	1.36
2.80	1.34	1.70	1.70	1.70	1.70	1.70	1.44	0.54	0.71	0.89	1.07	1.15	1.15	1.29
2.90	1.29	1.64	1.64	1.64	1.64	1.64	1.39	0.52	0.69	0.86	1.03	1.10	1.10	1.23
3.00	1.25	1.58	1.58	1.58	1.58	1.58	1.33	0.50	0.67	0.83	1.00	1.06	1.06	1.18
3.10	1.21	1.53	1.53	1.53	1.53	1.53	1.28	0.48	0.65	0.81	0.97	1.02	1.02	1.13
3.20	1.17	1.48	1.48	1.48	1.48	1.48	1.24	0.47	0.63	0.78	0.94	0.98	0.98	1.09
3.30	1.14	1.43	1.43	1.43	1.43	1.43	1.20	0.45	0.61	0.76	0.91	0.95	0.95	1.04
3.40	1.10	1.39	1.39	1.39	1.39	1.39	1.16	0.44	0.59	0.74	0.88	0.92	0.92	1.01
3.50	1.07	1.35	1.35	1.35	1.35	1.35	1.12	0.43	0.57	0.71	0.86	0.89	0.89	0.97
3.60	1.04	1.31	1.31	1.31	1.31	1.31	1.08	0.42	0.56	0.69	0.83	0.86	0.86	0.93
3.70	1.01	1.27	1.27	1.27	1.27	1.27	1.05	0.41	0.54	0.68	0.81	0.83	0.83	0.90
3.80	0.99	1.24	1.24	1.24	1.24	1.24	1.02	0.39	0.53	0.66	0.79	0.81	0.81	0.87
3.90	0.96	1.21	1.21	1.21	1.21	1.21	0.99	0.38	0.51	0.64	0.77	0.79	0.79	0.86
4.00	0.94	1.18	1.18	1.18	1.18	1.18	0.96	0.38	0.50	0.63	0.75	0.78	0.78	0.84
4.10	0.91	1.12	1.12	1.12	1.12	1.12	0.93	0.37	0.49	0.61	0.73	0.77	0.77	0.82
4.20	0.89	1.07	1.07	1.07	1.07	1.07	0.89	0.36	0.48	0.60	0.71	0.76	0.76	0.81
4.30	0.87	1.02	1.02	1.02	1.02	1.02	0.86	0.35	0.47	0.58	0.70	0.75	0.75	0.79
4.40	0.85	0.98	0.98	0.98	0.98	0.98	0.83	0.34	0.45	0.57	0.68	0.74	0.74	0.78
4.50	0.83	0.94	0.94	0.94	0.94	0.94	0.80	0.33	0.44	0.56	0.67	0.72	0.72	0.77
4.60	0.82	0.90	0.90	0.90	0.90	0.90	0.78	0.33	0.43	0.54	0.65	0.71	0.71	0.75
4.70	0.80	0.86	0.86	0.86	0.86	0.86	0.75	0.32	0.43	0.53	0.64	0.70	0.70	0.74
4.80	0.78	0.83	0.83	0.83	0.83	0.83	0.73	0.31	0.42	0.52	0.63	0.69	0.69	0.73
4.90	0.77	0.80	0.80	0.80	0.80	0.80	0.71	0.31	0.41	0.51	0.61	0.68	0.68	0.72
5.00	0.75	0.77	0.77	0.77	0.77	0.77	0.68	0.30	0.40	0.50	0.60	0.67	0.67	0.70
5.10	0.74	0.74	0.74	0.74	0.74	0.74	0.66	0.29	0.39	0.49	0.59	0.66	0.66	0.69
5.20	0.71	0.71	0.71	0.71	0.71	0.71	0.65	0.29	0.38	0.48	0.58	0.65	0.65	0.68
5.30	0.69	0.69	0.69	0.69	0.69	0.69	0.63	0.28	0.38	0.47	0.57	0.65	0.65	0.67
5.40	0.66	0.66	0.66	0.66	0.66	0.66	0.61	0.28	0.37	0.46	0.56	0.64	0.64	0.66
5.50	0.64	0.64	0.64	0.64	0.64	0.64	0.59	0.27	0.36	0.45	0.55	0.63	0.63	0.65
5.60	0.62	0.62	0.62	0.62	0.62	0.62	0.58	0.27	0.36	0.45	0.54	0.62	0.62	0.64
5.70	0.60	0.60	0.60	0.60	0.60	0.60	0.56	0.26	0.35	0.44	0.53	0.61	0.61	0.63
5.80	0.58	0.58	0.58	0.58	0.58	0.58	0.55	0.26	0.34	0.43	0.52	0.60	0.60	0.62

Table 10 Working loads in suction ($kN\cdot m^{-2}$) – Panel: 1 m wide, 120 mm thick

Span (m)	Two supports							Three supports						
	Thickness of exterior facing (mm)						Pressure ($kN\cdot m^{-2}$)	Thickness of exterior facing (mm)						Pressure ($kN\cdot m^{-2}$)
	0.5			0.63				0.5			0.63			
No of fixings per support			No of fixings per support			No of fixings per support			No of fixings per support					
	3	4	5	3	4	5		3	4	5	3	4	5	
2.00	–	–	–	–	–	–	–	0.90	1.20	1.50	1.80	2.05	2.05	1.95
2.10	2.14	2.69	2.69	2.69	2.69	2.69	2.16	0.86	1.14	1.43	1.71	1.92	1.92	1.84
2.20	2.05	2.51	2.51	2.51	2.51	2.51	2.04	0.82	1.09	1.36	1.64	1.80	1.80	1.75
2.30	1.96	2.35	2.35	2.35	2.35	2.35	1.94	0.78	1.04	1.30	1.57	1.70	1.70	1.66
2.40	1.88	2.20	2.20	2.20	2.20	2.20	1.84	0.75	1.00	1.25	1.50	1.60	1.60	1.58
2.50	1.80	2.07	2.07	2.07	2.07	2.07	1.76	0.72	0.96	1.20	1.44	1.52	1.52	1.51
2.60	1.73	1.96	1.96	1.96	1.96	1.96	1.68	0.69	0.92	1.15	1.38	1.44	1.44	1.44
2.70	1.67	1.85	1.85	1.85	1.85	1.85	1.61	0.67	0.89	1.11	1.33	1.37	1.37	1.38
2.80	1.61	1.76	1.76	1.76	1.76	1.76	1.54	0.64	0.86	1.07	1.29	1.31	1.31	1.32
2.90	1.55	1.67	1.67	1.67	1.67	1.67	1.48	0.62	0.83	1.03	1.24	1.25	1.25	1.27
3.00	1.50	1.59	1.59	1.59	1.59	1.59	1.42	0.60	0.80	1.00	1.20	1.20	1.20	1.22
3.10	1.45	1.52	1.52	1.52	1.52	1.52	1.37	0.58	0.77	0.97	1.15	1.15	1.15	1.18
3.20	1.41	1.46	1.46	1.46	1.46	1.46	1.32	0.56	0.75	0.94	1.11	1.11	1.11	1.14
3.30	1.36	1.39	1.39	1.39	1.39	1.39	1.28	0.55	0.73	0.91	1.06	1.06	1.06	1.10
3.40	1.32	1.34	1.34	1.34	1.34	1.34	1.24	0.53	0.71	0.88	1.02	1.02	1.02	1.06
3.50	1.28	1.28	1.28	1.28	1.28	1.28	1.20	0.51	0.69	0.86	0.99	0.99	0.99	1.03
3.60	1.24	1.24	1.24	1.24	1.24	1.24	1.16	0.50	0.67	0.83	0.95	0.95	0.95	1.00
3.70	1.19	1.19	1.19	1.19	1.19	1.19	1.12	0.49	0.65	0.81	0.92	0.92	0.92	0.97
3.80	1.15	1.15	1.15	1.15	1.15	1.15	1.09	0.47	0.63	0.79	0.89	0.89	0.89	0.94
3.90	1.11	1.11	1.11	1.11	1.11	1.11	1.06	0.46	0.62	0.77	0.86	0.86	0.86	0.91
4.00	1.07	1.07	1.07	1.07	1.07	1.07	1.03	0.45	0.60	0.75	0.84	0.84	0.84	0.89
4.10	1.03	1.03	1.03	1.03	1.03	1.03	1.00	0.44	0.59	0.73	0.81	0.81	0.81	0.86
4.20	1.00	1.00	1.00	1.00	1.00	1.00	0.98	0.43	0.57	0.71	0.79	0.79	0.79	0.84
4.30	0.97	0.97	0.97	0.97	0.97	0.97	0.95	0.42	0.56	0.70	0.77	0.77	0.77	0.82
4.40	0.93	0.93	0.93	0.93	0.93	0.93	0.91	0.41	0.55	0.68	0.75	0.75	0.75	0.80
4.50	0.89	0.89	0.89	0.89	0.89	0.89	0.88	0.40	0.53	0.67	0.73	0.73	0.73	0.78
4.60	0.85	0.85	0.85	0.85	0.85	0.85	0.86	0.39	0.52	0.65	0.71	0.71	0.71	0.76
4.70	0.82	0.82	0.82	0.82	0.82	0.82	0.83	0.38	0.51	0.64	0.69	0.69	0.69	0.74
4.80	0.79	0.79	0.79	0.79	0.79	0.79	0.80	0.38	0.50	0.63	0.68	0.68	0.68	0.72
4.90	0.76	0.76	0.76	0.76	0.76	0.76	0.78	0.37	0.49	0.61	0.66	0.66	0.66	0.70
5.00	0.74	0.74	0.74	0.74	0.74	0.74	0.76	0.36	0.48	0.60	0.64	0.64	0.64	0.69
5.10	0.71	0.71	0.71	0.71	0.71	0.71	0.74	0.35	0.47	0.59	0.63	0.63	0.63	0.67
5.20	0.69	0.69	0.69	0.69	0.69	0.69	0.72	0.35	0.46	0.58	0.62	0.62	0.62	0.66
5.30	0.66	0.66	0.66	0.66	0.66	0.66	0.70	0.34	0.45	0.57	0.60	0.60	0.60	0.64
5.40	0.64	0.64	0.64	0.64	0.64	0.64	0.68	0.33	0.44	0.56	0.59	0.59	0.59	0.63
5.50	0.62	0.62	0.62	0.62	0.62	0.62	0.66	0.33	0.44	0.55	0.58	0.58	0.58	0.62
5.60	0.60	0.60	0.60	0.60	0.60	0.60	0.64	0.32	0.43	0.54	0.57	0.57	0.57	0.61
5.70	0.58	0.58	0.58	0.58	0.58	0.58	0.63	0.32	0.42	0.53	0.55	0.55	0.55	0.59
5.80	0.56	0.56	0.56	0.56	0.56	0.56	0.61	0.31	0.41	0.52	0.54	0.54	0.54	0.58
5.90	0.55	0.55	0.55	0.55	0.55	0.55	0.60	0.31	0.41	0.51	0.53	0.53	0.53	0.57
6.00	0.53	0.53	0.53	0.53	0.53	0.53	0.58	0.30	0.40	0.50	0.52	0.52	0.52	0.56
6.10	0.52	0.52	0.52	0.52	0.52	0.52	0.57	–	–	–	–	–	–	–
6.20	0.50	0.50	0.50	0.50	0.50	0.50	0.56	–	–	–	–	–	–	–
6.30	0.49	0.49	0.49	0.49	0.49	0.49	0.54	–	–	–	–	–	–	–
6.40	0.48	0.48	0.48	0.48	0.48	0.48	0.53	–	–	–	–	–	–	–

Table 11 Working loads in suction ($kN \cdot m^{-2}$) – Panel: 1.2 m wide, 120 mm thick

Span (m)	Two supports							Three supports						
	Thickness of exterior facing (mm)						Pressure ($kN \cdot m^{-2}$)	Thickness of exterior facing (mm)						Pressure ($kN \cdot m^{-2}$)
	0.5			0.63				0.5			0.63			
	No of fixings per support			No of fixings per support				No of fixings per support			No of fixings per support			
3	4	5	3	4	5	3	4	5	3	4	5			
2.00	–	–	–	–	–	–	–	0.75	1.00	1.25	1.50	2.00	2.05	1.95
2.10	1.79	2.38	2.69	2.69	2.69	2.69	2.16	0.71	0.95	1.19	1.43	1.90	1.92	1.84
2.20	1.70	2.27	2.51	2.51	2.51	2.51	2.04	0.68	0.91	1.14	1.36	1.80	1.80	1.75
2.30	1.63	2.17	2.35	2.35	2.35	2.35	1.94	0.65	0.87	1.09	1.30	1.70	1.70	1.66
2.40	1.56	2.08	2.20	2.20	2.20	2.20	1.84	0.63	0.83	1.04	1.25	1.60	1.60	1.58
2.50	1.50	2.00	2.07	2.07	2.07	2.07	1.76	0.60	0.80	1.00	1.20	1.52	1.52	1.51
2.60	1.44	1.92	1.96	1.96	1.96	1.96	1.68	0.58	0.77	0.96	1.15	1.44	1.44	1.44
2.70	1.39	1.85	1.85	1.85	1.85	1.85	1.61	0.56	0.74	0.93	1.11	1.37	1.37	1.38
2.80	1.34	1.76	1.76	1.76	1.76	1.76	1.54	0.54	0.71	0.89	1.07	1.31	1.31	1.32
2.90	1.29	1.67	1.67	1.67	1.67	1.67	1.48	0.52	0.69	0.86	1.03	1.25	1.25	1.27
3.00	1.25	1.59	1.59	1.59	1.59	1.59	1.42	0.50	0.67	0.83	1.00	1.20	1.20	1.22
3.10	1.21	1.52	1.52	1.52	1.52	1.52	1.37	0.48	0.65	0.81	0.97	1.15	1.15	1.18
3.20	1.17	1.46	1.46	1.46	1.46	1.46	1.32	0.47	0.63	0.78	0.94	1.11	1.11	1.14
3.30	1.14	1.39	1.39	1.39	1.39	1.39	1.28	0.45	0.61	0.76	0.91	1.06	1.06	1.10
3.40	1.10	1.34	1.34	1.34	1.34	1.34	1.24	0.44	0.59	0.74	0.88	1.02	1.02	1.06
3.50	1.07	1.28	1.28	1.28	1.28	1.28	1.20	0.43	0.57	0.71	0.86	0.99	0.99	1.03
3.60	1.04	1.24	1.24	1.24	1.24	1.24	1.16	0.42	0.56	0.69	0.83	0.95	0.95	1.00
3.70	1.01	1.19	1.19	1.19	1.19	1.19	1.12	0.41	0.54	0.68	0.81	0.92	0.92	0.97
3.80	0.99	1.15	1.15	1.15	1.15	1.15	1.09	0.39	0.53	0.66	0.79	0.89	0.89	0.94
3.90	0.96	1.11	1.11	1.11	1.11	1.11	1.06	0.38	0.51	0.64	0.77	0.86	0.86	0.91
4.00	0.94	1.07	1.07	1.07	1.07	1.07	1.03	0.38	0.50	0.63	0.75	0.84	0.84	0.89
4.10	0.91	1.03	1.03	1.03	1.03	1.03	1.00	0.37	0.49	0.61	0.73	0.81	0.81	0.86
4.20	0.89	1.00	1.00	1.00	1.00	1.00	0.98	0.36	0.48	0.60	0.71	0.79	0.79	0.84
4.30	0.87	0.97	0.97	0.97	0.97	0.97	0.95	0.35	0.47	0.58	0.70	0.77	0.77	0.82
4.40	0.85	0.93	0.93	0.93	0.93	0.93	0.91	0.34	0.45	0.57	0.68	0.75	0.75	0.80
4.50	0.83	0.89	0.89	0.89	0.89	0.89	0.88	0.33	0.44	0.56	0.67	0.73	0.73	0.78
4.60	0.82	0.85	0.85	0.85	0.85	0.85	0.86	0.33	0.43	0.54	0.65	0.71	0.71	0.76
4.70	0.80	0.82	0.82	0.82	0.82	0.82	0.83	0.32	0.43	0.53	0.64	0.69	0.69	0.74
4.80	0.78	0.79	0.79	0.79	0.79	0.79	0.80	0.31	0.42	0.52	0.63	0.68	0.68	0.72
4.90	0.76	0.76	0.76	0.76	0.76	0.76	0.78	0.31	0.41	0.51	0.61	0.66	0.66	0.70
5.00	0.74	0.74	0.74	0.74	0.74	0.74	0.76	0.30	0.40	0.50	0.60	0.64	0.64	0.69
5.10	0.71	0.71	0.71	0.71	0.71	0.71	0.74	0.29	0.39	0.49	0.59	0.63	0.63	0.67
5.20	0.69	0.69	0.69	0.69	0.69	0.69	0.72	0.29	0.38	0.48	0.58	0.62	0.62	0.66
5.30	0.66	0.66	0.66	0.66	0.66	0.66	0.70	0.28	0.38	0.47	0.57	0.60	0.60	0.64
5.40	0.64	0.64	0.64	0.64	0.64	0.64	0.68	0.28	0.37	0.46	0.56	0.59	0.59	0.63
5.50	0.62	0.62	0.62	0.62	0.62	0.62	0.66	0.27	0.36	0.45	0.55	0.58	0.58	0.62
5.60	0.60	0.60	0.60	0.60	0.60	0.60	0.64	0.27	0.36	0.45	0.54	0.57	0.57	0.61
5.70	0.58	0.58	0.58	0.58	0.58	0.58	0.63	0.26	0.35	0.44	0.53	0.55	0.55	0.59
5.80	0.56	0.56	0.56	0.56	0.56	0.56	0.61	0.26	0.34	0.43	0.52	0.54	0.54	0.58
5.90	0.55	0.55	0.55	0.55	0.55	0.55	0.60	0.25	0.34	0.42	0.51	0.53	0.53	0.57
6.00	0.53	0.53	0.53	0.53	0.53	0.53	0.58	0.25	0.33	0.42	0.50	0.52	0.52	0.56
6.10	0.52	0.52	0.52	0.52	0.52	0.52	0.57	–	–	–	–	–	–	–
6.20	0.50	0.50	0.50	0.50	0.50	0.50	0.56	–	–	–	–	–	–	–
6.30	0.49	0.49	0.49	0.49	0.49	0.49	0.54	–	–	–	–	–	–	–
6.40	0.48	0.48	0.48	0.48	0.48	0.48	0.53	–	–	–	–	–	–	–

Table 12 Working loads in suction ($kN \cdot m^{-2}$) – Panel: 1 m wide, 150 mm thick

Span (m)	Two supports							Three supports						
	Thickness of exterior facing (mm)						Pressure ($kN \cdot m^{-2}$)	Thickness of exterior facing (mm)						Pressure ($kN \cdot m^{-2}$)
	0.5			0.63				0.5			0.63			
	No of fixings per support			No of fixings per support				No of fixings per support			No of fixings per support			
3	4	5	3	4	5	3	4	5	3	4	5			
2.50	1.80	2.16	2.16	2.16	2.16	2.16	2.61	0.72	0.96	1.20	1.44	1.59	1.59	1.70
2.60	1.73	2.06	2.06	2.06	2.06	2.06	2.46	0.69	0.92	1.15	1.38	1.51	1.51	1.63
2.70	1.67	1.97	1.97	1.97	1.97	1.97	2.32	0.67	0.89	1.11	1.33	1.44	1.44	1.56
2.80	1.61	1.89	1.89	1.89	1.89	1.89	2.20	0.64	0.86	1.07	1.29	1.37	1.37	1.50
2.90	1.55	1.81	1.81	1.81	1.81	1.81	2.08	0.62	0.83	1.03	1.24	1.32	1.32	1.45
3.00	1.50	1.74	1.74	1.74	1.74	1.74	1.98	0.60	0.80	1.00	1.20	1.26	1.26	1.40
3.10	1.45	1.67	1.67	1.67	1.67	1.67	1.89	0.58	0.77	0.97	1.16	1.21	1.21	1.35
3.20	1.41	1.61	1.61	1.61	1.61	1.61	1.80	0.56	0.75	0.94	1.13	1.16	1.16	1.30
3.30	1.36	1.56	1.56	1.56	1.56	1.56	1.72	0.55	0.73	0.91	1.09	1.12	1.12	1.26
3.40	1.32	1.50	1.50	1.50	1.50	1.50	1.65	0.53	0.71	0.88	1.06	1.08	1.08	1.22
3.50	1.29	1.46	1.46	1.46	1.46	1.46	1.58	0.51	0.69	0.86	1.03	1.04	1.04	1.19
3.60	1.25	1.41	1.41	1.41	1.41	1.41	1.52	0.50	0.67	0.83	1.00	1.01	1.01	1.15
3.70	1.22	1.37	1.37	1.37	1.37	1.37	1.46	0.49	0.65	0.81	0.97	0.97	0.97	1.12
3.80	1.18	1.33	1.33	1.33	1.33	1.33	1.40	0.47	0.63	0.79	0.94	0.94	0.94	1.09
3.90	1.15	1.29	1.29	1.29	1.29	1.29	1.35	0.46	0.62	0.77	0.91	0.91	0.91	1.06
4.00	1.13	1.25	1.25	1.25	1.25	1.25	1.31	0.45	0.60	0.75	0.89	0.89	0.89	1.03
4.10	1.10	1.22	1.22	1.22	1.22	1.22	1.26	0.44	0.59	0.73	0.86	0.86	0.86	1.01
4.20	1.07	1.18	1.18	1.18	1.18	1.18	1.22	0.43	0.57	0.71	0.84	0.84	0.84	0.98
4.30	1.05	1.15	1.15	1.15	1.15	1.15	1.18	0.42	0.56	0.70	0.83	0.83	0.83	0.95
4.40	1.02	1.12	1.12	1.12	1.12	1.12	1.14	0.41	0.55	0.68	0.81	0.81	0.81	0.92
4.50	1.00	1.10	1.10	1.10	1.10	1.10	1.11	0.40	0.53	0.67	0.80	0.80	0.80	0.90
4.60	0.98	1.07	1.07	1.07	1.07	1.07	1.07	0.39	0.52	0.65	0.78	0.79	0.79	0.87
4.70	0.96	1.04	1.04	1.04	1.04	1.04	1.04	0.38	0.51	0.64	0.77	0.78	0.78	0.85
4.80	0.94	1.02	1.02	1.02	1.02	1.02	1.01	0.38	0.50	0.63	0.75	0.77	0.77	0.82
4.90	0.92	0.99	0.99	0.99	0.99	0.99	0.97	0.37	0.49	0.61	0.73	0.76	0.76	0.80
5.00	0.90	0.96	0.96	0.96	0.96	0.96	0.94	0.36	0.48	0.60	0.72	0.75	0.75	0.78
5.10	0.88	0.93	0.93	0.93	0.93	0.93	0.90	0.35	0.47	0.59	0.71	0.74	0.74	0.76
5.20	0.87	0.90	0.90	0.90	0.90	0.90	0.87	0.35	0.46	0.58	0.69	0.73	0.73	0.75
5.30	0.85	0.88	0.88	0.88	0.88	0.88	0.84	0.34	0.45	0.57	0.68	0.72	0.72	0.73
5.40	0.83	0.85	0.85	0.85	0.85	0.85	0.81	0.33	0.44	0.56	0.67	0.71	0.71	0.71
5.50	0.82	0.83	0.83	0.83	0.83	0.83	0.78	0.33	0.44	0.55	0.65	0.71	0.71	0.69
5.60	0.80	0.81	0.81	0.81	0.81	0.81	0.76	0.32	0.43	0.54	0.64	0.70	0.70	0.68
5.70	0.79	0.79	0.79	0.79	0.79	0.79	0.73	0.32	0.42	0.53	0.63	0.69	0.69	0.66
5.80	0.77	0.77	0.77	0.77	0.77	0.77	0.71	0.31	0.41	0.52	0.62	0.68	0.68	0.65
5.90	0.75	0.75	0.75	0.75	0.75	0.75	0.69	0.31	0.41	0.51	0.61	0.67	0.67	0.64
6.00	0.73	0.73	0.73	0.73	0.73	0.73	0.67	0.30	0.40	0.50	0.60	0.66	0.66	0.62
6.10	0.71	0.71	0.71	0.71	0.71	0.71	0.65	-	-	-	-	-	-	-
6.20	0.69	0.69	0.69	0.69	0.69	0.69	0.63	-	-	-	-	-	-	-
6.30	0.68	0.68	0.68	0.68	0.68	0.68	0.61	-	-	-	-	-	-	-
6.40	0.66	0.66	0.66	0.66	0.66	0.66	0.59	-	-	-	-	-	-	-
6.50	0.65	0.65	0.65	0.65	0.65	0.65	0.57	-	-	-	-	-	-	-
6.60	0.63	0.63	0.63	0.63	0.63	0.63	0.56	-	-	-	-	-	-	-
6.70	0.62	0.62	0.62	0.62	0.62	0.62	0.54	-	-	-	-	-	-	-
6.80	0.61	0.61	0.61	0.61	0.61	0.61	0.53	-	-	-	-	-	-	-
6.90	0.59	0.59	0.59	0.59	0.59	0.59	0.52	-	-	-	-	-	-	-
7.00	0.58	0.58	0.58	0.58	0.58	0.58	0.50	-	-	-	-	-	-	-
7.10	0.57	0.57	0.57	0.57	0.57	0.57	0.49	-	-	-	-	-	-	-
7.20	0.56	0.56	0.56	0.56	0.56	0.56	0.48	-	-	-	-	-	-	-

Table 13 Working loads under suction ($kN \cdot m^{-2}$) – Panel: 1.2 m wide, 150 mm thick

Span (m)	Two supports							Three supports						
	Thickness of exterior facing (mm)						Pressure ($kN \cdot m^{-2}$)	Thickness of exterior facing (mm)						Pressure ($kN \cdot m^{-2}$)
	0.5			0.63				0.5			0.63			
No of fixings per support			No of fixings per support			No of fixings per support			No of fixings per support					
	3	4	5	3	4	5		3	4	5	3	4	5	
2.50	1.50	2.00	2.16	2.16	2.16	2.16	2.61	0.60	0.80	1.00	1.20	1.59	1.59	1.70
2.60	1.44	2.92	2.06	2.06	2.06	2.06	2.46	0.58	0.77	0.96	1.15	1.51	1.51	1.63
2.70	1.39	1.85	1.97	1.97	1.97	1.97	2.32	0.56	0.74	0.93	1.11	1.44	1.44	1.56
2.80	1.34	1.79	1.89	1.89	1.89	1.89	2.20	0.54	0.71	0.89	1.07	1.37	1.37	1.50
2.90	1.29	1.72	1.81	1.81	1.81	1.81	2.08	0.52	0.69	0.86	1.03	1.32	1.32	1.45
3.00	1.25	1.67	1.74	1.74	1.74	1.74	1.98	0.50	0.67	0.83	1.00	1.26	1.26	1.40
3.10	1.21	1.61	1.67	1.67	1.67	1.67	1.89	0.48	0.65	0.81	0.97	1.21	1.21	1.35
3.20	1.17	1.56	1.61	1.61	1.61	1.61	1.80	0.47	0.63	0.78	0.94	1.16	1.16	1.30
3.30	1.14	1.52	1.56	1.56	1.56	1.56	1.72	0.45	0.61	0.76	0.91	1.12	1.12	1.26
3.40	1.10	1.47	1.50	1.50	1.50	1.50	1.65	0.44	0.59	0.74	0.88	1.08	1.08	1.22
3.50	1.07	1.43	1.46	1.46	1.46	1.46	1.58	0.43	0.57	0.71	0.86	1.04	1.04	1.19
3.60	1.04	1.39	1.41	1.41	1.41	1.41	1.52	0.42	0.56	0.69	0.83	1.01	1.01	1.15
3.70	1.01	1.35	1.37	1.37	1.37	1.37	1.46	0.41	0.54	0.68	0.81	0.97	0.97	1.12
3.80	0.99	1.32	1.33	1.33	1.33	1.33	1.40	0.39	0.53	0.66	0.79	0.94	0.94	1.09
3.90	0.96	1.28	1.29	1.29	1.29	1.29	1.35	0.38	0.51	0.64	0.77	0.91	0.91	1.06
4.00	0.94	1.25	1.25	1.25	1.25	1.25	1.31	0.38	0.50	0.63	0.75	0.89	0.89	1.03
4.10	0.91	1.22	1.22	1.22	1.22	1.22	1.26	0.37	0.49	0.61	0.73	0.86	0.86	1.01
4.20	0.89	1.18	1.18	1.18	1.18	1.18	1.22	0.36	0.48	0.60	0.71	0.84	0.84	0.98
4.30	0.87	1.15	1.15	1.15	1.15	1.15	1.18	0.35	0.47	0.58	0.70	0.83	0.83	0.95
4.40	0.85	1.12	1.12	1.12	1.12	1.12	1.14	0.34	0.45	0.57	0.68	0.81	0.81	0.92
4.50	0.83	1.10	1.10	1.10	1.10	1.10	1.11	0.33	0.44	0.56	0.67	0.80	0.80	0.90
4.60	0.82	1.07	1.07	1.07	1.07	1.07	1.07	0.33	0.43	0.54	0.65	0.79	0.79	0.87
4.70	0.80	1.04	1.04	1.04	1.04	1.04	1.04	0.32	0.43	0.53	0.64	0.78	0.78	0.85
4.80	0.78	1.02	1.02	1.02	1.02	1.02	1.01	0.31	0.42	0.52	0.63	0.77	0.77	0.82
4.90	0.77	0.99	0.99	0.99	0.99	0.99	0.97	0.31	0.41	0.51	0.61	0.76	0.76	0.80
5.00	0.75	0.96	0.96	0.96	0.96	0.96	0.94	0.30	0.40	0.50	0.60	0.75	0.75	0.78
5.10	0.74	0.93	0.93	0.93	0.93	0.93	0.90	0.29	0.39	0.49	0.59	0.74	0.74	0.76
5.20	0.72	0.90	0.90	0.90	0.90	0.90	0.87	0.29	0.38	0.48	0.58	0.73	0.73	0.75
5.30	0.71	0.88	0.88	0.88	0.88	0.88	0.84	0.28	0.38	0.47	0.57	0.72	0.72	0.73
5.40	0.69	0.85	0.85	0.85	0.85	0.85	0.81	0.28	0.37	0.46	0.56	0.71	0.71	0.71
5.50	0.68	0.83	0.83	0.83	0.83	0.83	0.78	0.27	0.36	0.45	0.55	0.71	0.71	0.69
5.60	0.67	0.81	0.81	0.81	0.81	0.81	0.76	0.27	0.36	0.45	0.54	0.70	0.70	0.68
5.70	0.66	0.79	0.79	0.79	0.79	0.79	0.73	0.26	0.35	0.44	0.53	0.69	0.69	0.66
5.80	0.65	0.77	0.77	0.77	0.77	0.77	0.71	0.26	0.34	0.43	0.52	0.68	0.68	0.65
5.90	0.64	0.75	0.75	0.75	0.75	0.75	0.69	0.25	0.34	0.42	0.51	0.67	0.67	0.64
6.00	0.63	0.73	0.73	0.73	0.73	0.73	0.67	0.25	0.33	0.42	0.50	0.66	0.66	0.62
6.10	0.61	0.71	0.71	0.71	0.71	0.71	0.65	-	-	-	-	-	-	-
6.20	0.60	0.69	0.69	0.69	0.69	0.69	0.63	-	-	-	-	-	-	-
6.30	0.60	0.68	0.68	0.68	0.68	0.68	0.61	-	-	-	-	-	-	-
6.40	0.59	0.66	0.66	0.66	0.66	0.66	0.59	-	-	-	-	-	-	-
6.50	0.58	0.65	0.65	0.65	0.65	0.65	0.57	-	-	-	-	-	-	-
6.60	0.57	0.63	0.63	0.63	0.63	0.63	0.56	-	-	-	-	-	-	-
6.70	0.56	0.62	0.62	0.62	0.62	0.62	0.54	-	-	-	-	-	-	-
6.80	0.55	0.61	0.61	0.61	0.61	0.61	0.53	-	-	-	-	-	-	-
6.90	0.54	0.59	0.59	0.59	0.59	0.59	0.52	-	-	-	-	-	-	-
7.00	0.54	0.58	0.58	0.58	0.58	0.58	0.50	-	-	-	-	-	-	-
7.10	0.53	0.57	0.57	0.57	0.57	0.57	0.49	-	-	-	-	-	-	-
7.20	0.52	0.56	0.56	0.56	0.56	0.56	0.48	-	-	-	-	-	-	-

5.7 It is recommended that the panels are not used where impact resistance is required such as areas at high risk of hard or large body impacts.

5.8 The fixings used with the panels should have a pull-through or pull-over resistance equal to or greater than that shown in Table 14. Fixings should not be placed less than 200 mm from the interlocking edge of the panel.

Table 14 Typical pull-out resistance of fixings (kN)

Type of fixing ⁽³⁾	Under normal wind load			
	Nominal thickness of external facings (mm)			
	0.50	0.60	0.75	1.00
Coach screw diameter 8 mm Wood screw diameter 6.5 mm } Minimum anchorage of 50 mm	0.75	1.50	1.80	1.80
Self-drilling diameter 6.3 mm ⁽¹⁾ 1.5 ≤ t ≤ 3.0 mm	0.75	1.50	1.80	1.80
Self-drilling diameter 5.5 mm ⁽²⁾ > 3 mm	0.75	1.50	2.00	3.00

(1) Supporting frame steel of thickness 1.5 ≤ t ≤ 3 mm.

(2) Supporting frame steel of thickness t > 3 mm.

(3) Minimum washer size = 19 mm diameter, 1 mm thickness.

6 Behaviour in relation to fire



6.1 Steel components with a Class 0 or 'low risk' as defined in the Building Regulations are unrestricted under the following requirements of the national Building Regulations:

England and Wales — Approved Document B, Table 10 and section 13.5

Scotland — Mandatory Standards 2.5, 2.6 and 2.7, clauses 2.5.1⁽¹⁾, 2.5.2⁽¹⁾, 2.6.1⁽¹⁾ to 2.6.7⁽¹⁾, 2.7.1⁽¹⁾ and 2.7.2⁽¹⁾ respectively.

(1) Technical Handbook (Non-Domestic).

Northern Ireland — Technical Booklet E, Tables 2.1, 3.1 and 4.1.



6.2 Steel panels meeting the criteria given in section 6.1 are suitable for use on walls more than one metre from a relevant boundary.



6.3 Where a wall construction incorporating the wall panels (including any service penetrations and incorporated intumescent seals) is subject to fire resistance requirements, it is the responsibility of the user to provide details of an appropriate assessment or test carried out by a UKAS (United Kingdom Accreditation Service) approved testing laboratory.

6.4 Constructions incorporating the panels must include suitable provision for fire protection to the structural framework and junctions with other elements. Any cavities within a completed wall must include cavity barriers in accordance with the national Building Regulations.

6.5 Any openings through the panels must be protected by cavity barriers.

6.6 The Promfire Through Fix wall panels are Loss Prevention Certification Board certified to LPS 1208 *Fire resistance requirements for elements of construction used to provide compartmentation*.

7 Weathertightness



7.1 When sealed with an appropriate sealant and installed in accordance with sections 13 and 14 the product should be weathertight when used within exposure conditions related to recommended maximum design wind loads given in Tables 4 to 13.

7.2 The weathertightness of the product will not be adversely affected by deflection expected during normal service.

8 Thermal insulation



8.1 A wall constructed with the system panels will meet or satisfy the requirements of the national Building Regulations:

England and Wales — Approved Document L1, Table 1

Scotland — Mandatory Standard 6.2

Northern Ireland — Technical Booklet F, Table 1.2.

8.2 The thermal transmittance values for the panels are given in Table 15. The thermal conductivity (λ) value of the insulation has been taken as 0.041 W·m⁻¹·K⁻¹.

8.3 The thermal insulation fully fits the panels and the junctions between the panels can adequately limit heat loss. Providing junctions and openings are designed in accordance with the Accredited Construction Details (ACDs), the default psi values from BRE Information Paper IP 1/06 *Assessing the effects of thermal bridging at junctions and around openings*, Table 3, may be used in Target Emission Rate calculations to SAP 2005 or the Simplified Building Energy Model (SBEM).

Table 15 Panel U values⁽¹⁾⁽²⁾

Thickness of panel ⁽³⁾ (mm)	U value (W·m ⁻² ·K ⁻¹)	ψ ⁽⁴⁾⁽⁵⁾⁽⁶⁾ (W·m ⁻¹ ·K ⁻¹)
61	0.62	0.100
83	0.46	0.005
97	0.40	0.003
118	0.33	0.002
147	0.27	0.002

- (1) Overall U value for the panel = $U_c + (\psi L_p + nX)/A$
 U_c = centre panel U value (W·m⁻²·K⁻¹)
 L = width of panel (length of interlocking section) (m)
 ψ = linear edge loss (as above)
 n = number of fixings
 L_p = length of panel edge (m)
 X = coefficient of the particular type of fixing (W·m⁻¹)
 A = area of panels (m²).
- (2) Values relate to all internal and external skin types and thicknesses.
- (3) Other panel thicknesses are available but are outside the scope of this Certificate. Further information can be obtained from the Certificate holder.
- (4) Edge losses relate to panel-to-panel junctions.
- (5) The effect of the thermal bridging effect of fixings should be considered in accordance with BS EN ISO 6946 : 2007.
- (6) The edge effect associated with other junction details should be calculated in accordance with section 14.10.

8.4 Junctions with other elements should be designed to limit heat loss. Guidance given in BRE report (BR 262 : 2002) *Thermal insulation : avoiding risks* or BRE Information Paper IP 1/06 is acceptable.

8.5 It is essential that corners and junctions between elements are filled with insulation on site to maintain the insulation envelope.

9 Air leakage

To minimise air leakage, the panel must be installed and sealed in accordance with the Certificate holder's recommendations at all laps, penetrations, and around the perimeter. The standard panel construction, correctly installed, has been shown to be capable of achieving an acceptable air leakage rate.

10 Condensation risk

10.1 In common with all metal skin constructions, there is a risk of condensation; this can arise as either surface condensation at thermal bridging or interstitial condensation within the wall construction.

Surface condensation

10.2 The internal temperature at which surface condensation will occur on the internal surface of the wall is dependent on both the internal relative humidity and the external temperature. The risk of condensation occurring on the internal surfaces other than the fixing screws is negligible.

10.3 In buildings likely to experience high internal relative humidities (eg building internal humidity classes 4 and 5) (see Table 16), there is a risk of condensation forming on the fixing screws penetrating the panel. The designer should anticipate the areas of the structure that could be at risk from sustained sources of humidity and take the necessary measures to prevent any such problems (see section 2.5).

Table 16 Building internal humidity classes

Humidity class ⁽¹⁾	Building type
1	storage areas
2	offices, shops
3	dwellings with low occupancy
4	dwellings with high occupancy, sports halls, kitchens, canteens, buildings heated with unflued gas heaters
5	special buildings, eg laundries, breweries, swimming pools

- (1) As referenced in BS EN ISO 13788 : 2002 and BS 5250 : 2002.

Interstitial condensation

10.4 The risk of interstitial condensation will be minimal, provided the continuous internal steel faces of the panel are:

- adequately sealed and installed in accordance with sections 13 and 14, and
- not penetrated.

10.5 For buildings in internal humidity class 5 and in buildings or areas of a building with special internal design conditions, a hygrothermal assessment of the proposed wall system should be undertaken using the guidance given in BS 5250 : 2002, BS 5925 : 1991 and BS 6229 : 2003, to establish whether special provisions are required such as additional ventilation or air-conditioning within the building to maintain the internal conditions within acceptable limits. Advice should be sought from the Certificate holder.

10.6 Additional sealing may be necessary for wall panels enclosing air-conditioned rooms, to reduce the risk of condensation.

11 Maintenance



11.1 The panels should be inspected regularly (at least once a year) for accidental damage. Minor damage to the coating can be repaired by re-coating using the appropriate touch-up paint system. Non-structurally damaged panels can be repaired by a specialist.

11.2 In addition, the following maintenance actions should be carried out:

- removal of all vegetation (for example moss) as well as any other non-compatible material deposited on the surface of the cladding
- the integrity of the support structure should be monitored (problems with the support structure may affect the cladding) and any problems should be rectified as soon as they are noted.

11.3 In industrial and coastal areas it may be necessary to clean the surface periodically by hosing with water and a bleach-free domestic cleaning product (abrasives or solvents should not be used under any circumstances). This will restore appearance and remove potentially corrosive deposits. It may be necessary to clean soffits in any environment. Excessive washing should be avoided.

11.4 A planned maintenance cycle should be introduced if any extended design life is required. If a high-aesthetic appearance is required, maintenance painting should be considered at regular intervals. Considerations such as aspect, location and colour also need to be taken into account. The Certificate holder can give advice on suitable paints and maintenance systems.



11.5 The panels can be replaced by removing the fastening bolts of the damaged panel and the two adjacent panels. The adjacent panels should be pushed outward to enable the damaged panel to pivot and be removed. These stages can be carried out in reverse to install the new panel.

12 Durability



12.1 The durability and service life of the wall panels will depend upon the sheet and coating material, location, immediate environment, aspect faced, the components being undamaged during installation (see section 7), and the intended use of the building.

12.2 A designer should consider using stainless steel panels for any installations that are located within 2 km of the sea⁽¹⁾.

(1) Further information can be obtained from the Certificate holder.

12.3 A wall constructed from galvanized steel and finished with an appropriate coating should have a minimum service life in accordance with the relevant Agrément Certificate for the coating (see Table 2).

12.4 In general, colour changes should be slight and uniform on any one elevation.

12.5 Designers should ensure the fixings selected for use with the panels are suitable for the appropriate environmental conditions.

Installation

13 General

13.1 Installation of Induswall Insulated Wall Cladding Panels is carried out by trained and experienced specialist walling contractors.

13.2 Care must be taken to maintain a uniform surface appearance, for example, if all the panels are oriented in different directions a checkerboard effect will appear on the completed construction (due to the finish of the individual panels). The panels are supplied coated with a coloured film to help prevent this effect. Blue film indicates the side of the panel that faces into the building, and white film indicates the external face of the panel.

13.3 Care must be taken to ensure the dimensions, configuration and position of the supporting structure are compatible with the position of the panel joints.

14 Procedure

14.1 The cladding is installed onto a horizontal supporting frame, the panels are slotted together with the interlocking joints vertical. The panels are butted together to form the horizontal joint, this joint should be covered with a sealing plate.

Base of the cladding panel

14.2 A Z-shaped sealing plate incorporating a drip detail is fixed to the lower section of the structural frame (see Figure 2). Compressible foam tape 20 mm by 10 mm is placed on the vertical riser and the wall panel is fixed through this to the supporting structure. The base of the panel is wedged during installation and fixing to ensure there is a clearance of at least 5 mm between the sealing plate and the panel ends.

Figure 2 Typical vertical panel installation

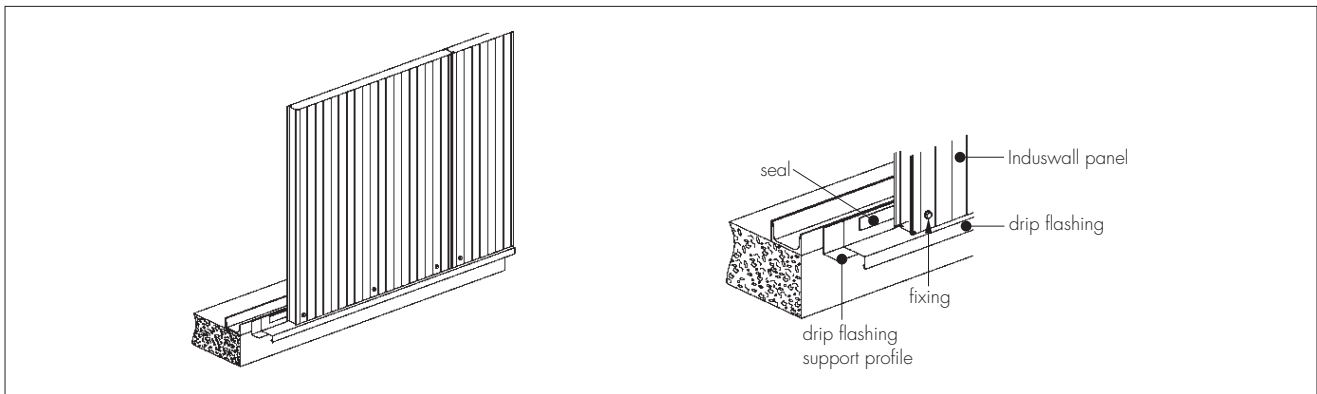

Horizontal installation and installation onto a sloping surface

14.3 The panels should be carefully aligned with the structural frame. A profiled rail section is mechanically fixed to the supporting structure and a 20 mm by 10 mm foam seal is fitted. The panels are installed onto the rail and fixed through the foam sealing tape into the supporting structure (see Figure 3).

Figure 3 Typical horizontal panel installation

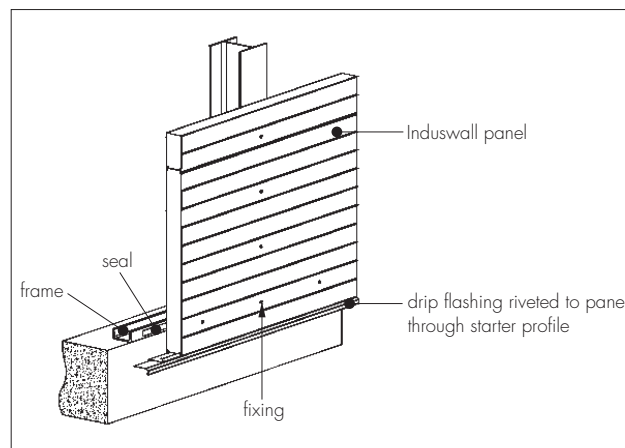

14.4 Special care should be taken at panel joints to ensure the appropriate level of airtightness is maintained.

14.5 A bead of silicone sealant or polyurethane foam is applied at the interface between horizontal joints and vertical elements (such as openings, jambs, corners and cover strips), this helps to ensure continuity of the seal and thermal conductivity between the panels, supports or shaped accessories.

Panel fixing

14.6 The panels cannot be used to compensate for deviations in frame alignment. The alignment tolerances applicable to frames are:

- Vertical alignment ± 10 mm per 10 m in height
- Horizontal alignment ± 10 mm per 10 m in length.

14.7 Care must be taken when installing the panels onto multiple (more than two) supports. The variations in the vertical alignment of the supports should be considered, these variations may be further exaggerated by dimensional differences between the panels. Installing in these situations could induce stresses that may cause distortions such as creases or bubbles, to appear in the panels.

14.8 The panel fixing is carried out with a minimum of three fixings per support and per panel width, these should be distributed at 400 mm intervals on either side of the panel centreline and, if necessary, additional fixings should be distributed uniformly across the panel width. The distance from the fixing centreline to the transverse edge of the panel must be between 20 mm and 600 mm. The distance from the fixing centreline to the longitudinal edge of the panel should not be less than 200 mm.

Top of the cladding panel

14.9 The cladding panel should be fixed to the upper frame member; the end of the panel must not overhang the frame by more than 600 mm. The internal side of the joint is covered with a shaped steel sealing plate and 20 mm by 10 mm foam seals. The external side of the joint is also covered with a shaped steel sealing plate (see section 14.13).

Corners

14.10 Care should be taken to ensure the corners (external and internal) are in alignment with the supporting frame. Corner joints between panels are covered with shaped steel sections and are sealed using a 20 mm by 10 mm foam seal. With a horizontal or sloping installation, additional silicon sealant is applied at joints (see Figures 2, 3 and 4) and a shaped closer is fixed to the end of the panel. In addition, a bead of silicone sealant or polyurethane foam is used to help prevent the ingress of run-off water.

14.11 The shaped steel sections are fixed using stainless steel rivets or stainless steel bolts typically at two fixings per metre.

Figure 4 Typical installation onto sloped surfaces

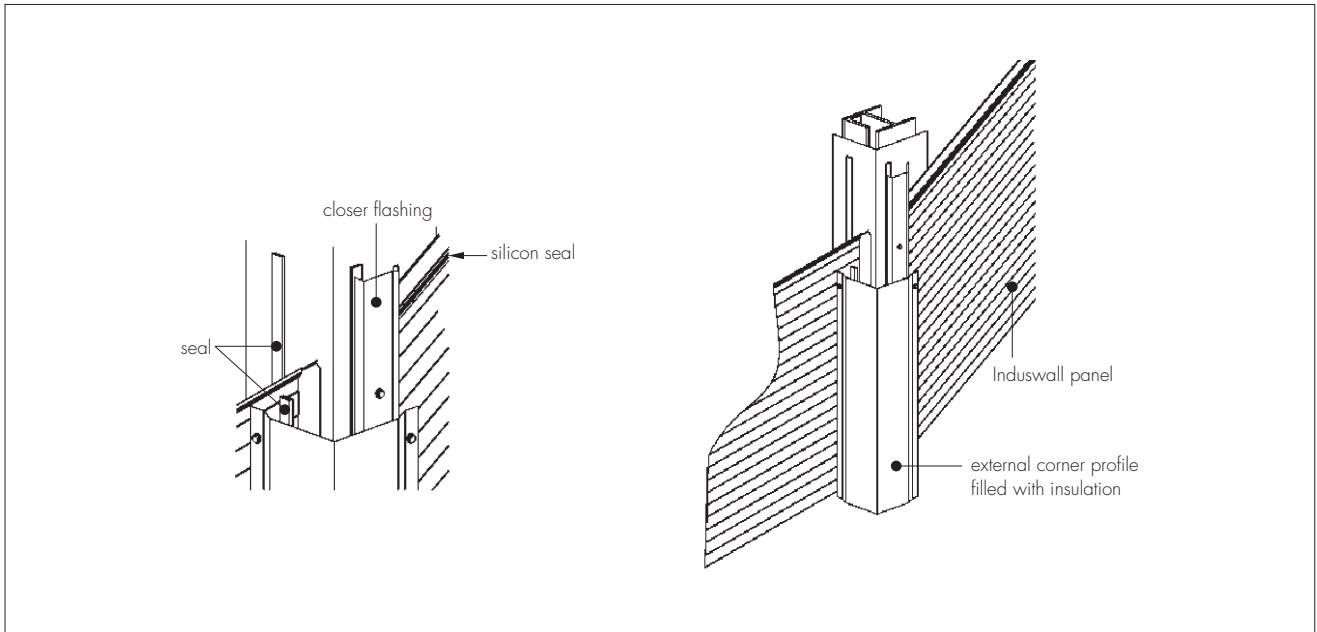

Junctions between the panels and solid walls or other elements

14.12 As with corners, shaped steel sections are used to cover the joints and additional foam seals (20 mm by 10 mm on panel side, and 30 mm by 20 mm foam seal on wall side) and thermal insulation are used to ensure continuity of airtightness and thermal performance (see Figure 5).

Figure 5 Typical junctions between panels and other elements

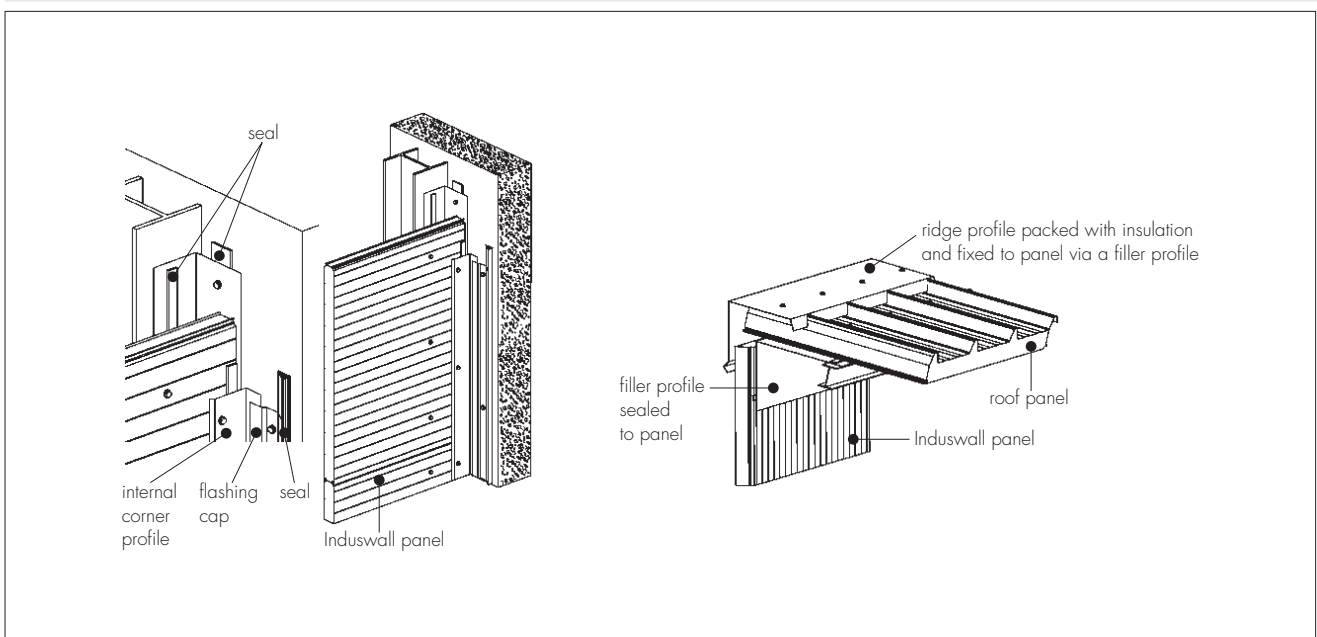

Panel cutting

14.13 The panels and sheet steel accessories can be cut using suitable equipment (such as a jig saw, nibbler or a fine-toothed saw), encrustation of hot particles on the panel must be avoided and all swarf and chips must be removed immediately on installation. Chainsaw type cutters must not be used under any circumstances.

Openings

14.14 Panel openings must be supported by a structural frame, with header joists and jamb sections mounted onto the supporting structure (see Figures 2 and 3). Opening details should include sealing plates incorporating drips and foam seals as described in section 14.2. The procedure for the creation of openings is:

- peripheral panels are fastened to the structural frame
- panel edges are sealed
- additional air seals are placed onto the cover sections
- folded steel sheet cover sections with a minimum thickness of 0.75 mm (such as sealing plates) are positioned and fixed over the lintel or at the soffit and over the jambs or stanchions.

14.15 The joint between the supporting structure and the panels must be sealed with silicone sealant or filled with polyurethane foam.

Drilling and bolting

14.16 Excessive compression of the exterior skin of panels must be avoided; fastening drivers should be equipped with a depth stop and a device that enables adjustment of torque to help prevent overtightening. The last few millimetres should be tightened manually if necessary.

15 Investigations

15.1 An assessment was made of reports relating to:

- fire resistance
- durability of the system
- compatibility of materials in contact
- practicability of installation
- weathertightness
- structural performance (load span)
- thermal conductivity
- dimensions
- compressive strength
- bending stiffness.

15.2 The manufacturing process was examined including the methods adopted for quality control, and details were obtained of the quality and composition of the materials used.

Bibliography

- BS 476-22 : 1987 *Fire tests on building materials and structures — Methods for determination of the fire resistance of non-loadbearing elements of construction*
- BS 5250 : 2002 *Code of practice for control of condensation in buildings*
- BS 5925 : 1991 *Code of practice for ventilation principles and designing for natural ventilation*
- BS 6229 : 2003 *Flat roofs with continuously supported coverings — Code of practice*
- BS 6399-2 : 1997 *Loading for buildings — Code of practice for wind loads*
- BS EN 826 : 1996 *Thermal insulating products for building applications — Determination of compression behaviour*
- BS EN 1602 : 1997 *Thermal insulating products for building applications — Determination of the apparent density*
- BS EN 1607 : 1996 *Thermal insulating products for building applications — Determination of tensile strength perpendicular to faces*
- BS EN 10088-2 : 2005 : *Stainless steels — Technical delivery conditions for sheet/plate and strip of corrosion resisting steels for general purposes*
- BS EN 10143 : 2006 *Continuously hot-dip metal coated steel sheet and strip — Tolerances on dimensions and shape*
- BS EN 10169-2 : 2006 *Continuously organic coated (coil coated) steel flat products — Products for building exterior applications*
- BS EN 10346 : 2009 *Continuously hot-dip coated steel flat products — Technical delivery conditions*
- BS EN 14509 : 2006 *Self-supporting double-skin metal faced insulating panels — Factory made products — Specifications*
- BS EN ISO 6946 : 2007 *Building components and building elements — Thermal resistance and thermal transmittance — Calculation method*
- BS EN ISO 13788 : 2002 *Hygrothermal performance of building components and buildings elements — Internal surface temperature to avoid critical surface humidity and interstitial condensation — Calculation methods*
- ISO 9001 : 2000 *Quality management systems — Requirements*

16 Conditions

16.1 This Certificate:

- relates only to the product/system that is named and described on the front page
- is granted only to the company, firm or person named on the front page — no other company, firm or person may hold or claim any entitlement to this Certificate
- is valid only within the UK
- has to be read, considered and used as a whole document — it may be misleading and will be incomplete to be selective
- is copyright of the BBA
- is subject to English law.

16.2 Publications and documents referred to in this Certificate are those that the BBA deems to be relevant at the date of issue or re-issue of this Certificate and include any: Act of Parliament; Statutory Instrument; Directive; Regulation; British, European or International Standard; Code of Practice; manufacturers' instructions; or any other publication or document similar or related to the aforementioned.

16.3 This Certificate will remain valid for an unlimited period provided that the product/system and the manufacture and/or fabrication including all related and relevant processes thereof:

- are maintained at or above the levels which have been assessed and found to be satisfactory by the BBA
- continue to be checked as and when deemed appropriate by the BBA under arrangements that it will determine
- are reviewed by the BBA as and when it considers appropriate.

16.4 In granting this Certificate, the BBA is not responsible for:

- the presence or absence of any patent, intellectual property or similar rights subsisting in the product/system or any other product/system
- the right of the Certificate holder to manufacture, supply, install, maintain or market the product/system
- individual installations of the product/system, including the nature, design, methods and workmanship of or related to the installation
- the actual works in which the product/system is installed, used and maintained, including the nature, design, methods and workmanship of such works.

16.5 Any information relating to the manufacture, supply, installation, use and maintenance of this product/system which is contained or referred to in this Certificate is the minimum required to be met when the product/system is manufactured, supplied, installed, used and maintained. It does not purport in any way to restate the requirements of the Health & Safety at Work etc Act 1974, or of any other statutory, common law or other duty which may exist at the date of this Certificate; nor is conformity with such information to be taken as satisfying the requirements of the 1974 Act or of any statutory, common law or other duty of care. In granting this Certificate, the BBA does not accept responsibility to any person or body for any loss or damage, including personal injury, arising as a direct or indirect result of the manufacture, supply, installation, use and maintenance of this product/system.

