

**Floline**

Factory Road  
Blaydon Haugh Industrial Estate  
Blaydon-on-Tyne, Tyne and Wear NE21 5RU  
Tel: 0191-414 0414 Fax: 0191-414 8425  
e-mail: info@flolinepipes.com  
website: www.flolinepipes.com

**FLOLINE TWINWALL DRAINAGE SYSTEM**

**FLOLINE TWINWALL 150 MM TO 375 MM PIPES AND COUPLERS**

This Certificate is issued under the Highway Authorities' Product Approval Scheme (HAPAS) by the British Board of Agrément (BBA) in conjunction with the Highways Agency (HA) (acting on behalf of the overseeing organisations of the Department for Transport; the Scottish Executive; the Welsh Assembly Government; the Department for Regional Development, Northern Ireland), the County Surveyors' Society, the Local Government Technical Advisers' Group, and industry bodies. HAPAS Agrément Certificates are normally each subject to a review every five years.

**PRODUCT SCOPE AND SUMMARY OF CERTIFICATE**

This Certificate relates to Floline Twinwall 150 mm to 375 mm Pipes and Couplers, for use as filter and carrier pipes for highway drainage.

**AGRÉMENT CERTIFICATION INCLUDES:**

- factors relating to compliance with HAPAS requirements
- factors relating to compliance with Regulations where applicable
- independently verified technical specification
- assessment criteria and technical investigations
- design considerations
- installation guidance
- regular surveillance of production
- formal five-yearly review.

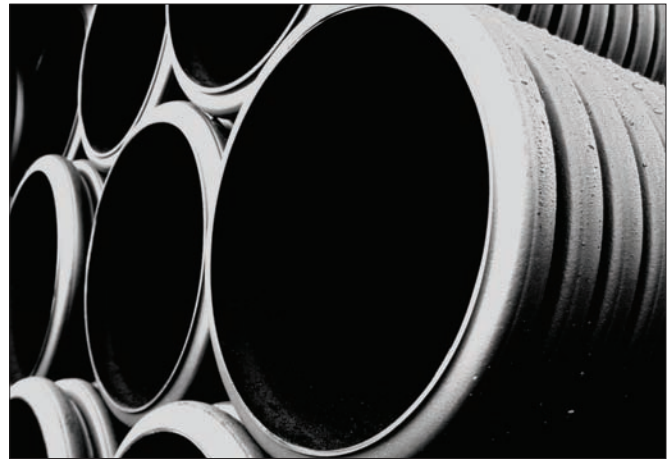

**KEY FACTORS ASSESSED**

**Strength** — the pipes and couplers have adequate strength to resist loads associated with installation and service (see section 5).

**Performance of joints** — the system will remain watertight under normal service conditions (see section 6).

**Durability** — the system will have a service life in excess of 50 years (see section 10).

The BBA has awarded this Agrément Certificate to the company named above for the products described herein. These products have been assessed by the BBA as being fit for their intended use provided they are installed, used and maintained as set out in this Certificate.

On behalf of the British Board of Agrément



Brian Chamberlain  
Head of Approvals — Engineering



Greg Cooper  
Chief Executive

Date of First issue: 22 December 2008

*The BBA is a UKAS accredited certification body — Number 113. The schedule of the current scope of accreditation for product certification is available in pdf format via the UKAS link on the BBA website at [www.bbacerts.co.uk](http://www.bbacerts.co.uk)*

*Readers are advised to check the validity of this Agrément Certificate by either referring to the BBA's website ([www.bbacerts.co.uk](http://www.bbacerts.co.uk)) or contacting the BBA direct.*

# HAPAS Requirements

## Requirements

The general requirements for drains are contained in the Manual of Contract Documents for Highway Works (MCHW)<sup>(1)</sup>, Volume 1 and Volume 2.

The general requirements for structured wall pipes and fittings are contained in the MCHW Volume 1, Clause 518.

Further information and guidance is given in MCHW, Volume 3, Drawing Numbers F1 and F2.

Additional site requirements may be included on particular contracts.

(1) The MCHW is operated by the Overseeing Organisations : The Highways Agency (HA), Transport Scotland, the Welsh Assembly Government and The Department for Regional Development (Northern Ireland).

## Regulations

### Construction (Design and Management) Regulations 2007

### Construction (Design and Management) Regulations (Northern Ireland) 2007

Information in this Certificate may assist the client, CDM co-ordinator, designer and contractors to address their obligations under these Regulations.

See sections: 2 Delivery and site handling (2.1) and 11 General.

## General

This Certificate relates to Floline Twinwall 150 mm to 375 mm Pipes and Couplers, high-density polyethylene filter and carrier pipes in diameters of 150 mm, 225 mm, 300 mm and 375 mm. The pipes and couplers comply with MCHW, Volume 1, Clause 518, and are for use in highway drainage for the collection and disposal of surface and sub-surface water.

## Technical Specification

### 1 Description

1.1 Twinwall filter and carrier (perforated and unperforated) pipes are manufactured in black polyethylene outer and inner layers<sup>(1)</sup> by a twin extrusion process. Two high-density polyethylene pipes are extruded simultaneously, one inside the other, and heat-welded together in one continuous process.

(1) Other colours for the inner layer are available on special request — further information can be obtained from the manufacturer.

1.2 Twinwall pipes are supplied with plain ends in sizes 150 mm, 225 mm, 300 mm and 375 mm.

1.3 The products tested and covered by this Certificate are manufactured from material with the specification given in Table 1.

Table 1 Material properties/specification<sup>(1)</sup>

Property	Test method reference	Specification
Tensile properties	EN 638, ISO 527-2	Sample 1B at 50 mm min <sup>-1</sup> ≥ 18 MPa
Oxygen induction time	EN 728	≥ 4 min
Melt flow rate	ISO 1133	≤ 0.75 g (10 min) <sup>-1</sup> 2.16 kg at 190°C
Density	ISO 1183	≥ 935 kgm <sup>-3</sup>
Heat reversion	ISO 12091	110°C ± 2°C (pass)
Effects of heating (injection moulded fittings only)	EN 763	N/A

(1) This table is in the format of Appendix 5/7 of MCHW, Volume 2. It is used to satisfy Clause 518.2 of MCHW, Volume 1.

1.4 The outer wall is corrugated and the inner wall is smooth finished. Details and dimensions are given in Table 2 and Figure 1.

Table 2 Pipe dimensions

Nom <sup>(1)</sup> internal pipe diameter, $d_1$ (mm)	Min <sup>(2)</sup> internal pipe diameter (mm)	Nom <sup>(1)</sup> external pipe diameter, $d_2$ (mm)	$t_1$ min (mm)	$t_2$ min (mm)	$t_3$ min (mm)	Nom <sup>(1)</sup> length (m)	Nom <sup>(1)</sup> weight (kgm <sup>-1</sup> )
150	145	176.00	0.7	1.0	0.8	6	1.3
225	220	266.00	0.8	2.0	1.0	6	2.5
300	294	353.00	1.0	2.1	1.3	6	5.0
375	372	435.50	1.6	2.9	1.5	6	6.7

(1) Nom = nominal.

(2) Min = minimum.

Figure 1 Twinwall pipe

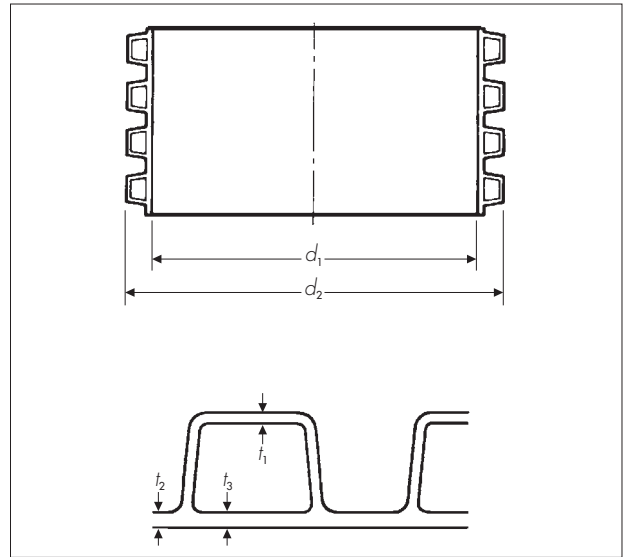

1.5 Black polypropylene couplers are made by the Certificate holder and are available for each size of pipe (see Table 3 and Figure 2).

Table 3 Coupler dimensions

Nominal internal pipe diameter (mm)	Internal, diameter $d_3$ (min) (mm)	Nominal external, diameter $d_4$ (mm)	Nominal length ( $L$ ) (mm)	Nominal seal height ( $h$ ) (mm)
150	176.0	182	183	15
225	265.4	275	260	21
300	353.0	365	280	28
375	433.0	447	333	33

Figure 2 Couplers

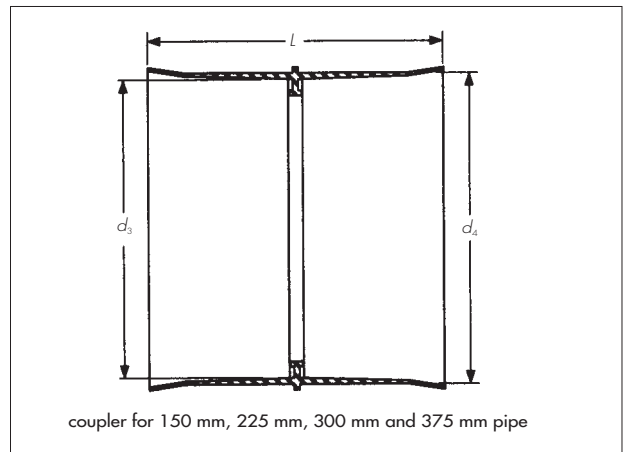

1.6 Each coupler requires two rubber seals which can be obtained from Certificate holder, manufactured to BS EN 681-1 : 1996 (see Figure 3). The seals must be fitted in accordance with the installation instructions to ensure a watertight joint.

Figure 3 Seals

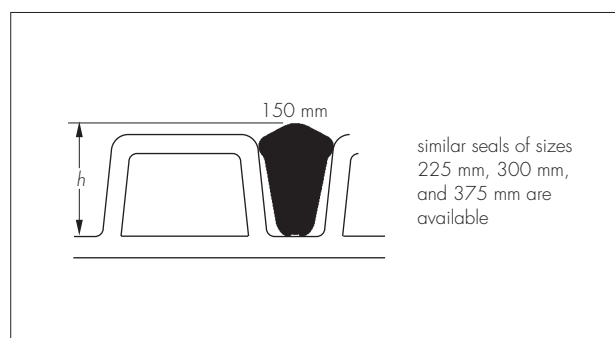

1.7 Pipes can be supplied either perforated or unperforated. Perforated pipe is available with the slots in the dwell between corrugations equally spaced around the circumference and offset<sup>(1)</sup> symmetrically for alternate dwells along the pipe length (see Table 4 and Figure 4). Alternatively, the slots are located on one half only of the pipe and thus the permeable area is approximately halved.

(1) Pipe sizes 300 mm and 375 mm do not have the offset for alternate dwells.

**Table 4 Perforated pipe details**

Nominal internal pipe diameter (mm)	No of slots per dwell	No of rows of slots	No of dwells per metre	Slot length (mm)	Slot width (mm)	Permeable area (minimum) (mm <sup>2</sup> m <sup>-1</sup> )
150 <sup>(1)</sup>	6	6	45	20–52	1–2	5400
150 <sup>(2)</sup>	4	4	45	20–52	1–2	3600
225 <sup>(1)</sup>	3	6	30	25–60	1–2	2250
225 <sup>(2)</sup>	2	4	30	25–60	1–2	1500
300 <sup>(1)</sup>	6	6	25	25–75	1–2	3750
300 <sup>(2)</sup>	4	4	25	25–75	1–2	2500
375 <sup>(1)</sup>	10	10	19	20–45	1.5–3.6	6000
375 <sup>(2)</sup>	5	5	19	20–45	1.5–3.6	3000

(1) Perforated.

(2) Half perforated.

**Figure 4 Details of perforations**

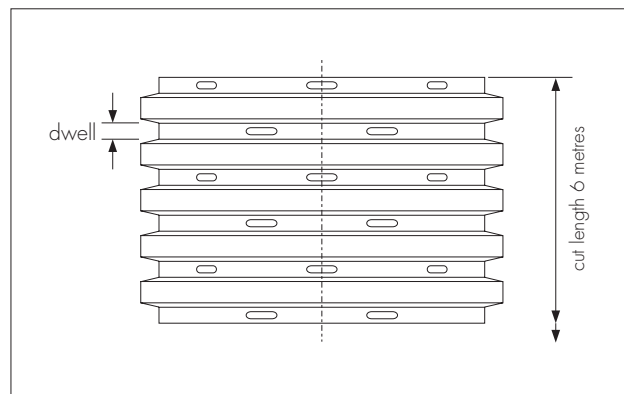

1.8 Continuous quality control is exercised during manufacture. Checks include:

**Pipes**

- dimensional accuracy
- impact resistance
- short-term stiffness

**Couplers**

- dimensional accuracy
- impact resistance.

1.9 A label bearing the BBA identification mark incorporating the number of this Certificate is attached to each pipe length and fitting or to each pack of pipes.

**2 Delivery and site handling**

2.1 Handling, storage and transportation should be in accordance with BS 5955-6 : 1980.

2.2 When long-term storage is envisaged, the pipes and couplers must be protected from direct sunlight. If protection cannot be provided, consideration must be given to the effects of daily exposure to direct sunlight:

- up to 3 months — negligible UV degradation but possible extreme surface temperatures of up to 80°C may cause some localised distortion
- 3 months to 12 months — may have significant effect on the impact resistance and physical properties
- over 12 months — damage will occur unless protection provided.

2.3 The manufacturer has the option of adding chemicals to provide enhanced UV stability on request.

2.4 Pipes are generally delivered in prepacked bundles and should be retained in their packaging until installation.

# Assessment and Technical Investigations

The following is a summary of the assessment and technical investigations carried out on Floline Twinwall 150 mm to 375 mm Pipes and Couplers.

## Design Considerations

### 3 General

Floline Twinwall 150 mm to 375 mm Pipes and Couplers (perforated and unperforated) comply with the requirements of the MCHW, Volume 1, Clause 518.5 for pipe, Clause 518.6 for couplers and Clause 518.7 for the system. When installed in accordance with the recommendations given in this Certificate, they are suitable for use in highways for the collection and disposal of surface and sub-surface water.

### 4 Practicability of installation

The pipes are installed easily using traditional drain-laying methods in accordance with HA requirements and MCHW, Volume 1, Clauses 503, 505, 518.7 and 518.8. The lengths in which the pipes are available and their lightness in weight are a significant advantage in handling and installation. Jointing of the pipes is achieved easily.

### 5 Strength

5.1 The pipes have a ring stiffness in excess of  $6 \text{ kNm}^{-2}$  and a creep ratio of less than 4 and have adequate resistance to static loads.

5.2 The pipes have adequate resistance to impact loads to which they may be subjected during installation and in service.

5.3 The pipes can be used as an alternative to the plastic pipes for surface water drains listed in Table 5/1 of the MCHW, Volume 1, and for safe bedding depth purposes may be assumed to have a standard dimension ratio (SDR) equivalent of not greater than 41.

### 6 Performance of joints

6.1 Joints on filter pipes made from pipe and couplers without the rubber seals are not partially watertight as defined in the MCHW, Volume 1, Clause 504.3.

6.2 Correctly made, the joints constructed from pipe and couplers with rubber seals remain watertight when subjected to deflection and distortion, and comply with the MCHW, Volume 1, Clauses 504.3 and 518.7 (see section 13).

### 7 Water infiltration

The slot area for the pipes exceeds the minimum requirement given in MCHW, Volume 1, Clause 518.3, of  $1000 \text{ mm}^2$  per metre length (see Table 4).

### 8 Flow characteristics

8.1 The pipes will have normal flow characteristics associated with PVC-U pipes.

8.2 Full-bore velocities are available from the *Tables for the Hydraulic Design of Pipes, Sewers and Channels*, Volume 2, 8th Edition by H R Wallingford and D I H Barr. The values are based on the Colebrook-White equation. An appropriate value of roughness coefficient should be selected when designing the drainage system. For new pipes, a value of  $0.006 \text{ mm}$  is applicable, but for designs, a value of  $0.6 \text{ mm}$  is generally used.

### 9 Maintenance

9.1 The slots are designed to restrict the ingress of silt into the drains.

9.2 Access to the system for cleaning should be provided by conventional methods.

9.3 The system can be rodded easily using flexible drain rods. In common with other standard plastic drainage systems, toothed root cutters and rods with metal ferrules, as used with some mechanical clearing systems, could damage the pipes and couplers and should not be used.

9.4 Tests indicate that the pipes have adequate resistance to water cleansing using pressure jetting equipment (see section 13.1). It is recommended that low pressure, high volume systems are utilised in accordance with MCHW, Volume 1, Clause 520.

### 10 Durability

In the opinion of the BBA, when used in the context of this Product Sheet, the material from which the pipes and couplers are manufactured will not significantly deteriorate and the anticipated life of the system will be in excess of 50 years.

# Installation

## 11 General

Floline Twinwall 150 mm to 375 mm Pipes and Couplers must be installed in accordance with HA requirements and MCHW, Volume 1, Clauses 503, 505, 518.7 and 518.8.

## 12 Procedures

12.1 For typical laying, trench and backfilling specification details reference should be made to Figure 5 and the MCHW, Volume 3, Drawing Nos F1 (Types T and S) and F2 (Types G, H and I).

Figure 5 Installation details

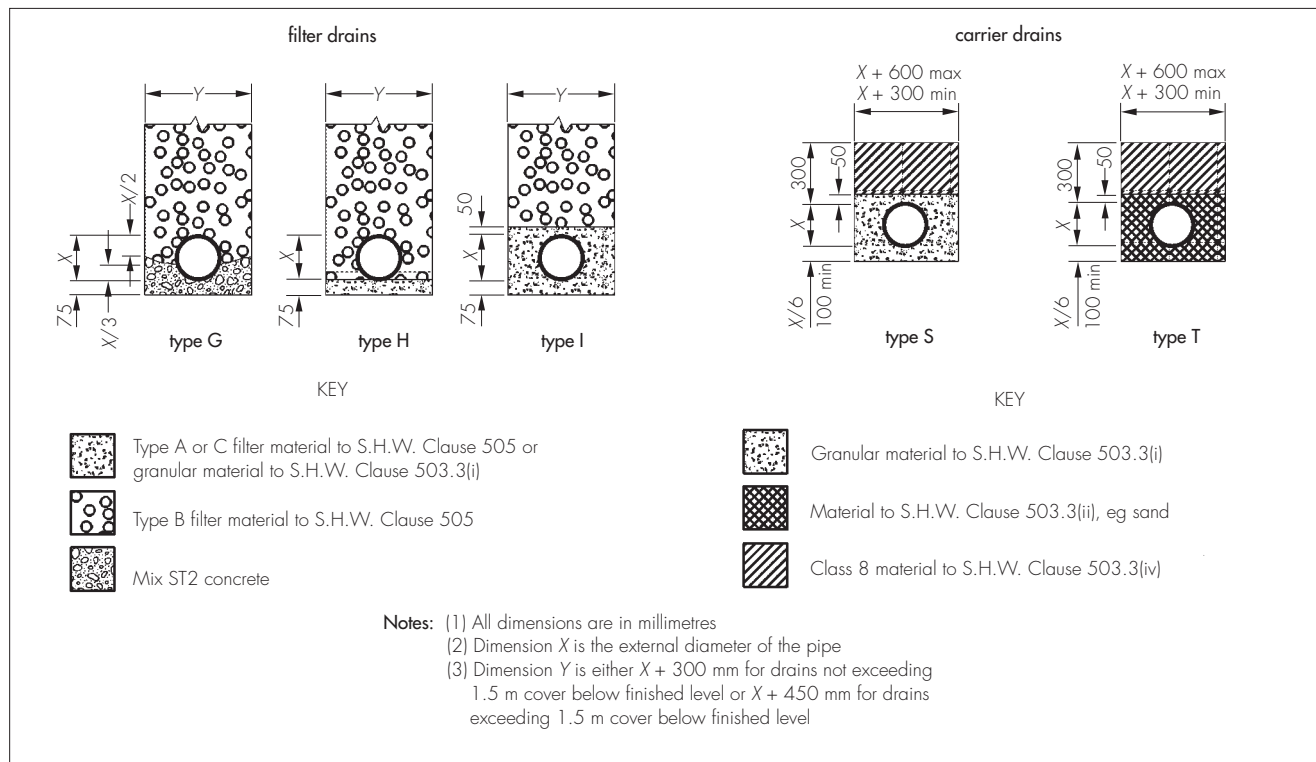

12.2 Pipes are cut easily using conventional hand tools, and should be cut square between the corrugations.

12.3 For a watertight joint, the pipe ends and coupler should be cleaned and a rubber seal fitted externally between the first and second corrugation in the pipe. The seal and inside of the coupler should be lubricated and the pipe pushed fully home to the central register either by hand, or using a lever if necessary.

12.4 The perforated and unperforated pipes and couplers must be protected against damage from site construction traffic.

12.5 Care should be taken during backfill to maintain the line and level of the pipeline. If necessary, the pipe should be restrained to prevent uplift.

## Technical Investigations

### 13 Tests

13.1 Tests were carried out on the pipe to determine compliance with MCHW, Volume 1, Clause 518.5, on:

- determination of ring stiffness to BS EN ISO 9969 : 1995
- creep ratio to BS EN ISO 9967 : 1995
- resistance to longitudinal bending to MCHW, Volume 1, Clause 518.11
- impact strength at 0°C and 23°C to BS EN 1411 : 1996 with a d25 striker of 1.0 kg mass
- rodding resistance to MCHW, Volume 1, Clause 518.12
- water jetting WRc method.

13.2 Tests were carried out on joined pipe to establish compliance with MCHW, Volume 1, Clause 518.7 on:

- leaktightness of joints to BS EN 1277 : 2003 when subjected to diameter distortion and angular deflection from 0.5 bar to -0.3 bar

- insertion force (ease of jointing)
- resistance to rodding.

13.3 Tests were carried out to establish the dimensional accuracy of the pipe, coupler and ring seal.

## 14 Investigations

14.1 An examination was made of data in relation to the effect of the production tolerances on the performance of the products.

14.2 An evaluation of existing data was made to assess material properties, chemical resistance and durability.

14.3 Calculations were carried out to determine the slot area of perforated pipes.

14.4 Visits to sites in progress were carried out to assess the practicability of installation.

14.5 The manufacturing process was examined, including the methods adopted for quality control, and details were obtained of the quality and composition of the materials used.

## Bibliography

BS 5955-6 : 1980 *Plastics pipework (thermoplastics materials) — Code of practice for the installation of unplasticized PVC pipework for gravity drains and sewers*

BS EN 681-1 : 1996 *Elastomeric seals — Material requirements for pipe joint seals used in water and drainage applications — Vulcanized rubber*

BS EN 1277 : 2003 *Plastics piping systems — Thermoplastics piping systems for buried non-pressure applications — Test methods for leaktightness of elastomeric sealing ring type joints*

BS EN 1411 : 1996 *Plastics piping and ducting systems — Thermoplastics pipes — Determination of resistance to external blows by the staircase method*

BS EN ISO 9967 : 1995 *Thermoplastics pipes — Determination of creep ratio*

BS EN ISO 9969 : 1995 *Thermoplastics pipes — Determination of ring stiffness*

EN 638 : 1994 *Plastics piping and ducting systems — Thermoplastics pipes — Determination of tensile properties*

EN 728 : 1997 *Plastics piping and ducting systems — Polyolefin pipes and fittings — Determination of oxidation induction time*

EN 763 : 1994 *Plastics piping and ducting systems — Injection moulded thermoplastics fittings — Test method for visually assessing effects of heating*

ISO 527-2 : 1993 *Plastics — Determination of tensile properties — Test conditions for moulding and extrusion plastics*

ISO 1133 : 1997 *Plastics — Determination of the melt mass-flow rate (MFR) and the melt volume-flow rate (MVR) of thermoplastics*

ISO 1183 : 1970 *Methods for determining the density and relative density (specific gravity) of plastics excluding cellular plastics*

ISO 12091 : 1995 *Structural wall thermoplastics pipes — Oven test*

Manual of Contract Documents for Highway Works, Volume 1 Specification for Highway Works, August 1998 (as amended)

Manual of Contract Documents for Highway Works, Volume 2 Notes for Guidance on the Specification for Highway Works, August 1998 (as amended)

Manual of Contract Documents for Highway Works, Volume 3 Highway Construction Details, March 1998 (as amended)

## 15 Conditions

15.1 This Certificate:

- relates only to the product/system that is named and described on the front page
- is granted only to the company, firm or person named on the front page — no other company, firm or person may hold or claim any entitlement to this Certificate
- is valid only within the UK
- has to be read, considered and used as a whole document — it may be misleading and will be incomplete to be selective
- is copyright of the BBA
- is subject to English law.

15.2 References in this Certificate to any Act of Parliament, Statutory Instrument, Directive or Regulation of the European Union, British, European or International Standard, Code of Practice, manufacturers' instructions or similar publication, are references to such publication in the form in which it was current at the date of this Certificate.

15.3 This Certificate will remain valid for an unlimited period provided that the product/system and the manufacture and/or fabrication including all related and relevant processes thereof:

- are maintained at or above the levels which have been assessed and found to be satisfactory by the BBA
- continue to be checked as and when deemed appropriate by the BBA under arrangements that it will determine
- are reviewed by the BBA as and when it considers appropriate
- remain in accordance with the requirements of Highways Authorities' Product Approval Scheme.

15.4 In granting this Certificate, the BBA is not responsible for:

- the presence or absence of any patent, intellectual property or similar rights subsisting in the product/system or any other product/system
- the right of the Certificate holder to manufacture, supply, install, maintain or market the product/system
- individual installations of the product/system, including the nature, design, methods and workmanship of or related to the installation
- the actual works in which the product/system is installed, used and maintained, including the nature, design, methods and workmanship of such works.

15.5 Any information relating to the manufacture, supply, installation, use and maintenance of this product/system which is contained or referred to in this Certificate is the minimum required to be met when the product/system is manufactured, supplied, installed, used and maintained. It does not purport in any way to restate the requirements of the Health & Safety at Work etc Act 1974, or of any other statutory, common law or other duty which may exist at the date of this Certificate; nor is conformity with such information to be taken as satisfying the requirements of the 1974 Act or of any statutory, common law or other duty of care. In granting this Certificate, the BBA does not accept responsibility to any person or body for any loss or damage, including personal injury, arising as a direct or indirect result of the manufacture, supply, installation, use and maintenance of this product/system.