



## Polypipe Civils Ltd

Union Works  
Bishop Meadow Road  
Loughborough LE11 5RE  
Tel: 01509 615100 Fax: 01509 265945

**Roads and Bridges  
Agrément Certificate  
No 90/R049**  
*Fifth issue\**

Designated by Government  
to issue  
European Technical  
Approvals

## RIDGIDUCT DUCTING SYSTEM

Conduite pour l'alimentation en eau, gaz et électricité  
Leitungsrohr für Wasser-, Gas-, und Electricitätsversorgungen

## Product



• THIS CERTIFICATE RELATES TO THE RIDGIDUCT DUCTING SYSTEM.

• The system is for use in highways as an underground ducting for electricity, gas and water supply services, and for street lighting cables and fibre optic cabling for telecommunications.

• The product must be in accordance with the requirements of the Highways Agency (HA); acting on behalf of the Department for Transport, the Scottish Executive Development Department, the Welsh Assembly Government, and the Department for Regional Development; Northern Ireland and the conditions set out in this Certificate.

This Front Sheet must be read in conjunction with the accompanying Detail Sheet, which provides information specific to the system.

## Highways Agency Requirements — Detail Sheet 1

### 1 Requirements

- 1.1 The requirements for ducting are contained in the Manual of Contract Documents for Highway Works (MCHW), Volumes 1 and 2, including any amendments.
- 1.2 Further requirements are contained in MCHW Volume 3, including any amendments.
- 1.3 Additional site requirements may be included on particular contracts.

### 2 Construction (Design and Management) Regulations 1994 (as amended) Construction (Design and Management) Regulations (Northern Ireland) 1995 (as amended)

Information in this Certificate may assist the client, planning supervisor, designer and contractors to address their obligations under these Regulations.

See sections: 2 Delivery and site handling (2.1), and 9 Installation — General (9.1).

## Additional Information

The management systems of Polypipe Civils Ltd have been assessed and registered as meeting the requirements of BS EN ISO 9002 : 1994 by the British Standards Institution Quality Assurance.

## Bibliography

BS EN ISO 9002 : 1994 *Quality systems. Model for quality assurance in production, installation and servicing*

Manual of Contract Documents for Highway Works, Volume 1 : *Specification for Highway Works* : May 2001 edition

Manual of Contract Documents for Highway Works, Volume 2 : *Notes for Guidance on the Specification for Highway Works* : 2001

Manual of Contract Documents for Highway Works, Volume 3 : *Highway Construction Details* : 2001, Drawing Nos F1 and F2 (1991)

## Conditions of Certification

### 3 Conditions

3.1 This Certificate:

- (a) relates only to the product that is described, installed, used and maintained as set out in this Certificate;
- (b) is granted only to the company, firm or person identified on the front cover — no other company, firm or person may hold or claim any entitlement to this Certificate;
- (c) has to be read, considered and used as a whole document — it may be misleading and will be incomplete to be selective;
- (d) is copyright of the BBA.

3.2 References in this Certificate to any Act of Parliament, Regulation made thereunder, Directive or

Regulation of the European Union, Statutory Instrument, Code of Practice, British Standard, manufacturers' instructions or similar publication, shall be construed as references to such publication in the form in which it was current at the date of this Certificate.

3.3 This Certificate will remain valid for an unlimited period provided that the product and the manufacture and/or fabricating process(es) thereof:

- (a) are maintained at or above the levels which have been assessed and found to be satisfactory by the BBA;
- (b) continue to be checked by the BBA or its agents;
- (c) are reviewed by the BBA as and when it considers appropriate; and
- (d) remain in accordance with the requirements of the Highways Agency.

3.4 In granting this Certificate, the BBA makes no representation as to:

- (a) the presence or absence of any patent or similar rights subsisting in the product or any other product;
- (b) the right of the Certificate holder to market, supply, install or maintain the product; and
- (c) the nature of individual installations of the product, including methods and workmanship.

3.5 Any recommendations relating to the use or installation of this product which are contained or referred to in this Certificate are the minimum standards required to be met when the product is used. They do not purport in any way to restate the requirements of the Health & Safety at Work etc Act 1974, or of any other statutory, common law or other duty which may exist at the date of this Certificate or in the future; nor is conformity with such recommendations to be taken as satisfying the requirements of the 1974 Act or of any present or future statutory, common law or other duty of care. In granting this Certificate, the BBA does not accept responsibility to any person or body for any loss or damage, including personal injury, arising as a direct or indirect result of the installation and use of this product.



In the opinion of the British Board of Agrément, the Ridgiduct Ducting System is fit for its intended use provided it is installed, used and maintained as set out in this Certificate. Certificate No 90/R049 is accordingly awarded to Polypipe Civils Ltd.

On behalf of the British Board of Agrément

A handwritten signature in black ink, appearing to read 'P. C. Hewson'.

Date of Fifth issue: 14th March 2003

Chief Executive

*\*Original Certificate issued 8th September 1989. This new Front Sheet includes addition of CDM Regulations, revised Conditions of Certification and the introduction of a Detail Sheet format.*



Polypipe Civils Ltd

**RIDGIDUCT TWIN-WALLED  
HIGH DENSITY POLYETHYLENE DUCTING**

Roads and Bridges  
Certificate No 90/R049  
**DETAIL SHEET 2**

## Product



• THIS DETAIL SHEET RELATES TO RIDGIDUCT TWIN-WALLED HIGH DENSITY POLYETHYLENE DUCTING.

• The product is for use in highways as underground ducting for electricity, gas and water supply services, and for street lighting cables and fibre optic cabling for telecommunications.

*This Detail Sheet must be read in conjunction with the Front Sheet, which gives, the Highways Agency (HA) requirements and the Conditions of Certification.*

## Technical Specification

### 1 Description

1.1 Ridgiduct Twin-Walled High Density Polyethylene Ducting is manufactured by a twin-extrusion process. Two pipes are extruded simultaneously, one inside the other, and heat-welded together in one continuous process.

1.2 The outer wall is corrugated and the inner wall is smooth finished. Details and dimensions are given in Table 1 and Figure 1.

Table 1 Dimensions

Manu- facturer's Code No	Internal dia (d <sub>1</sub> ) (mm)	External dia (d <sub>2</sub> ) (mm)	t <sub>1</sub> (mm)	t <sub>2</sub> (mm)	length (m)
RB 90	89	107	0.85	0.80	1, 2, 3 and 6
RB 94	94	110	0.70	0.60	1, 2, 3 and 6
RB 100	100	118	1.00	0.80	1, 2, 3 and 6
RB 125	125	148	1.00	0.90	1, 2, 3 and 6
RB 150	150	177	0.90	0.95	1, 2, 3 and 6

1.3 The product is available in a colour range of black, purple, orange, green, blue and yellow. The ducts are marked appropriately in accordance with the customer's requirements.

1.4 A black polypropylene coupler is used to join the ducts. A green coupler is used for green 90 mm duct. The couplers are manufactured by Polypipe Civils Ltd. Details of size are given in Table 2 and Figures 2, 3 and 4.

1.5 Jointing of the product with the couplers as described in section 2.4 produces a system with protection against penetration by solid foreign objects of 2.5 mm diameter or greater, i.e. an I.P. rating of 3 (first characteristic numeral) to BS EN 60529 : 1992.

Figure 1 Ridgiduct

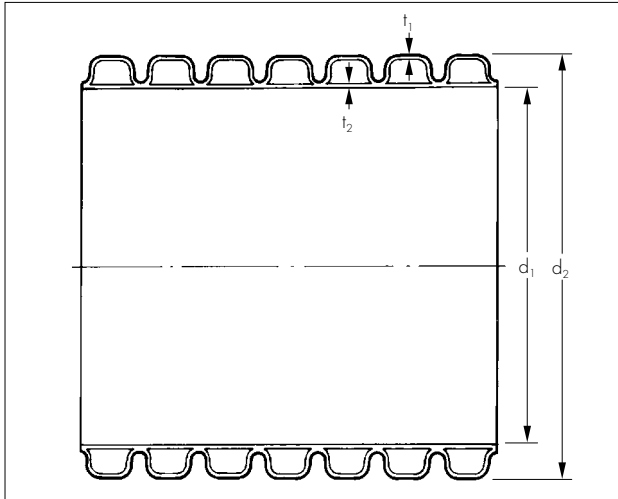

Table 2 Coupler dimensions

Coupler	External dia ( $d_3$ ) (mm)	Internal dia ( $d_2$ ) tapered end (mm)	Internal dia ( $d_1$ ) (mm)	L (mm)	t (mm)
90	113.5	108.20	107.35	172.50	2.5
94	114.5	111.25	111.60	100.00	2.0
100	125	119.4	117.5	97.25	2.5
125	155	148.25	147.5	101.60	2.5
150	185	178.5	177.0	123.00	2.5

1.6 When used with an optional sealed coupling, available from the Certificate holder, and elastomeric seal, Ridgiduct RB 94, RB 100 and RB 150 are suitable for motorway communications applications as a sealed system to BS EN 50086-2.4 : 1994 IP67.

1.7 Quality control includes checks on raw materials, dimensional checks, impact tests, compression tests and checks on adhesion of printing and internal static friction coefficient.

Figure 2 100 mm, 125 mm and 150 mm couplers

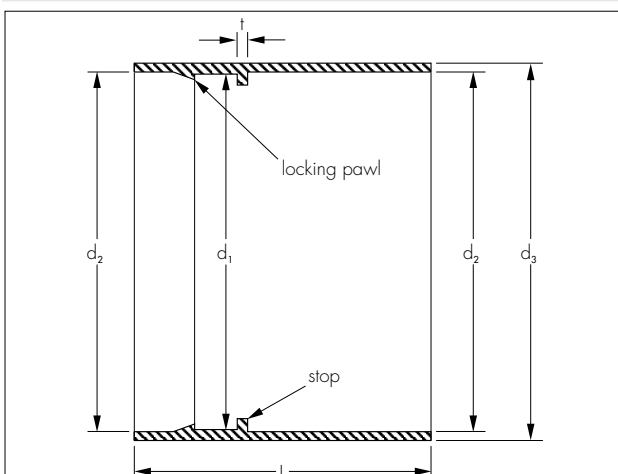

Figure 3 94 mm coupler

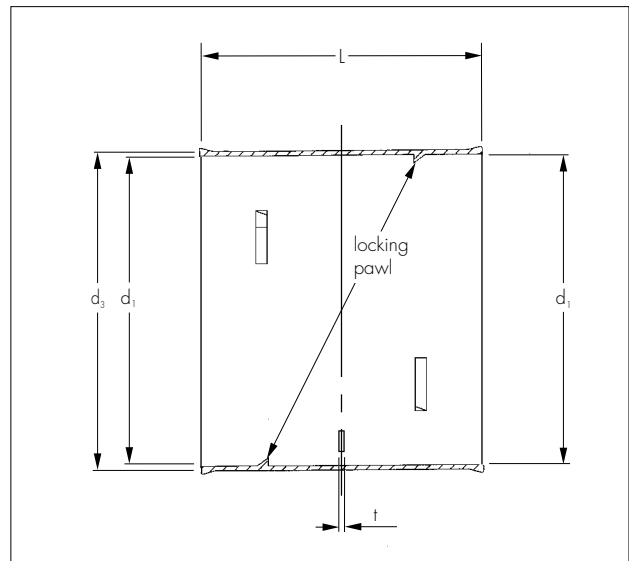
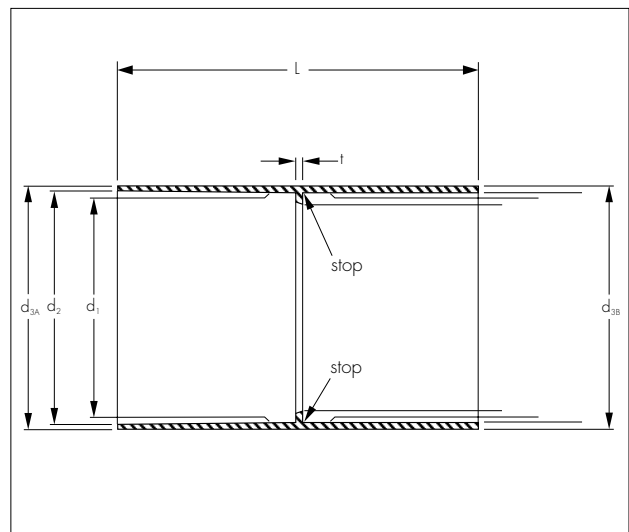

Figure 4 90 mm coupler



## 2 Delivery and site handling

2.1 The product is delivered to site strapped to pallets.

2.2 When used for electric cables, the ducts are marked with the legend 'electric cable duct'. The ducts are appropriately marked, in accordance with the customer's requirements.

2.3 The HDPE ducts and polypropylene couplers have good resistance to UV degradation but to avoid damage or deterioration in storage it is recommended that the ducts should be protected from direct sunlight. However, if this is unavoidable, the following mechanism of deterioration should be considered:

(1) Up to three months' daily exposure to direct sunlight will cause negligible UV degradation but extreme surface temperatures of up to 80°C are possible on exposed surfaces and may cause some localised distortion.

(2) Three to 12 months' daily exposure to direct sunlight may have a significant effect on the impact resistance and physical properties of the duct.

(3) Over 12 months' daily exposure to direct sunlight will damage the duct and should be avoided.

When used in the context of this Certificate, Ridgiduct will have adequate durability.

## Design Data

### 3 General

Ridgiduct Twin-Walled High Density Polyethylene Ducting, when installed in accordance with the recommendations given in this Certificate, is suitable for use in highways as underground ducting for electricity, gas and water supply services, and for street lighting cables and fibre optic cabling for cable television and telecommunications.

### 4 Strength

4.1 The product has adequate strength to resist the loads likely to be encountered during service when used and installed in accordance with the recommendations given in this Certificate.

4.2 The ducts can be used as an alternative to the plastics pipes listed in MCHW, Volume 1, Table 5/2 *Pipes for Ducts*.

4.3 The ducts will have adequate resistance to the impact loads normally encountered during handling and installation. The ducts meet the resistance to impact requirements defined as 'normal duty' and the resistance to compression requirements defined in 'type 450' of BS EN 50086-2.4 : 1994.

4.4 The ducts have an adequate resistance to long-term deformation. When tested in accordance with BS 4962 : 1989 the ducts have an ultimate pipe stiffness (STES) value in excess of  $1400 \text{ Nm}^{-2}$ .

### 5 Resistance to elevated temperatures

5.1 The maximum temperature to which the ducts and couplers will be subject in service as an electrical cable duct is dependent on the ground thermal conductivity, depth of burial, ground temperature and the heat load imposed by the electrical cable.

5.2 In general, cables with a surface temperature of up to  $60^\circ\text{C}$  will not affect the integrity of the ducts. For example, in a typical installation with a  $300 \text{ mm}^2$  copper cable carrying a current of 600 amps imposing a heat load of  $25 \text{ Wm}^{-1}$ , the cable would have a surface temperature of  $60^\circ\text{C}$ ; this would result in a mean internal duct temperature of  $45^\circ\text{C}$ .

5.3 The ducts have adequate resistance to long-term deformation at an elevated temperature of  $45^\circ\text{C}$ .

### 6 Resistance to chemicals

The high-density polyethylene used to manufacture Ridgiduct pipe and the polypropylene used to manufacture couplers have an adequate resistance to attack from chemicals likely to occur in soils and groundwater. Details of chemical resistance of high density polyethylene and polypropylene are given in CP 312-1 : 1973.

### 7 Practicability of installation

#### Ducts

7.1 The ducts can be installed easily under normal site conditions.

#### Cables

7.2 The ducts have a smooth internal surface and, when tested in accordance with ESI 12-24, Test TT3 *Static friction coefficient*, have a static coefficient of less than 0.22. The ducts and their joints do not present any internal projection or impedance to the installation or withdrawal of cables through the duct run.

## Installation

### 9 General

9.1 Ridgiduct Twin-Walled High Density Polyethylene Ducting must be installed in accordance with the general requirements and any additional site requirements (see section 1).

9.2 The general requirements are to be in accordance with MCHW, Volume 3, as shown in Figure 5.

9.3 Ducting laid in depths of cover other than those specified in Figure 5 must be laid in accordance with the procedures described in the contract with the Highways Agency (HA).

9.4 Ridgiduct must be adequately protected against damage from site construction traffic and from agricultural or similar operations.

9.5 When used as ducts for fibre optic cabling the recommendations in BS 7718 : 1996 should be followed.

### 10 Procedure

10.1 Joints are made by a simple push-fit of one duct length into the coupler attached to the adjacent length, ensuring that the connection is fully made.

10.2 Inspection points can be made in the conventional manner depending upon the type of services to be installed.

Figure 5 Highway construction details

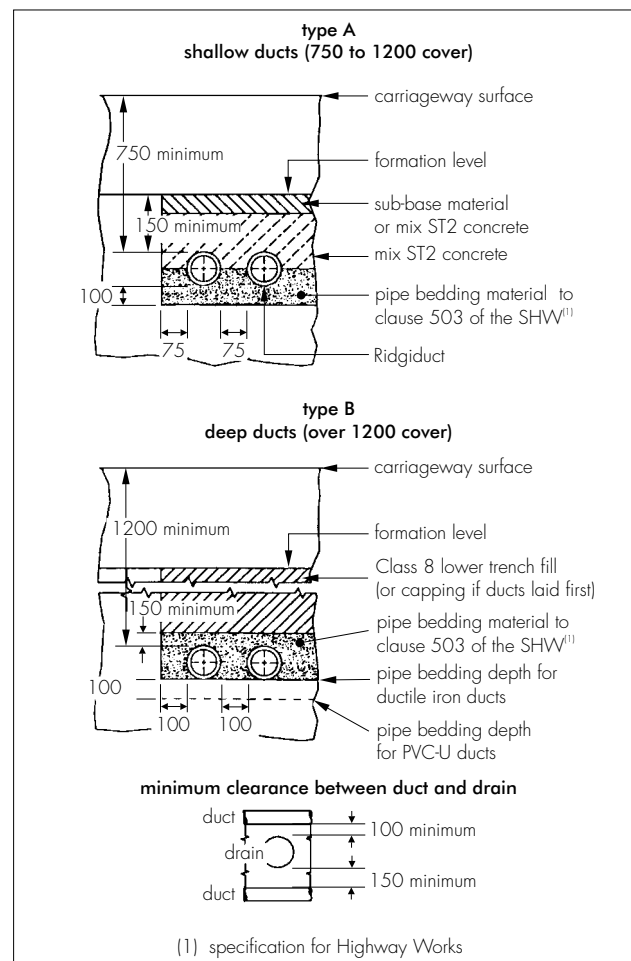

## Technical Investigations

The following is a summary of the technical investigations carried out on Ridgiduct Twin-Wall High Density Polyethylene Ducting.

### 11 Tests

11.1 As part of the assessment leading to the issue of the previous versions of this Certificate, tests were carried out to determine:

dimensional accuracy  
resistance to compression to BS EN 50086-2.4 : 1994  
impact strength at  $-5^{\circ}\text{C}$  to BS EN 50086-2.4 : 1994  
Vicat softening temperature to BS 2782-1 :  
Method 120B : 1990  
static friction coefficient to ESI (12-24), TT3  
visual examination to ESI (12-24), ST1  
adhesion of printing to ESI (12-24), ST2  
resistance to long-term deformation to  
BS EN ISO 9967 : 1995  
ease of joining  
resistance to penetration of simulated sharp aggregate  
watertightness of joints to BS EN 60529 : 1992  
degree of protection against foreign objects to  
BS EN 60529 : 1992, first characteristic numeral 3,  
Test condition 13.2.

11.2 Further tests have subsequently been carried out to determine:

dimensional accuracy to BS EN 50086-2.4 : 1994  
creep ratio at  $45^{\circ}\text{C}$  to BS EN ISO 9967 : 1995  
resistance to sharp objects to MCHW Volume 1  
clause 518.13  
resistance to compression to BS EN 50086-2.4 : 1994  
degrees of protection by enclosure to BS EN 60529 :  
1992 (an IP67 code was justified).

### 12 Investigations

12.1 An examination was made of data relating to:

chemical resistance  
heat dissipation  
effect of temperature  
practicability of installation  
material properties  
durability.

12.2 The manufacturing process was examined, including the methods adopted for quality control, and

details were obtained of the quality and composition of the materials used.

## Additional Information

The management systems of Polypipe Civils Ltd have been assessed and registered as meeting the requirements of BS EN ISO 9002 : 1994 by the British Standards Institution Quality Assurance.

## Bibliography

- BS 2782-1 : Method 120B : 1990 *Methods of testing plastics — Thermal properties — Determination of Vicat softening temperature of thermoplastics*
- BS 4962 : 1989 *Specification for plastics pipes and fittings for use as subsoil field drains*
- BS 7718 : 1996 *Code of practice for installation of fibre optic cabling*
- BS EN 50086-2.4 : 1994 *Specification for conduit systems for cable management — Part 2-4 : Particular requirements for conduit systems buried underground*
- BS EN 60529 : 1992 *Specification for degrees of protection provided by enclosures (IP code)*
- BS EN ISO 9002 : 1994 *Quality Systems — Model for quality assurance in production, installation and servicing*
- BS EN ISO 9967 : 1995 *Thermoplastics pipes — Determination of creep ratio*
- CP 312-1 : 1973 *Code of practice for plastics pipework (thermoplastics material) — General principles and choice of material*
- ESI (Electricity Supply Industry) 12-24 *Plastic ducts for buried electric cables*
- Manual of Contract Documents for Highway Works, Volume 1 : *Specification for Highway Works* : May 2001 edition
- Manual of Contract Documents for Highway Works, Volume 2 : *Notes for Guidance on the Specification for Highway Works* : 2001
- Manual of Contract Documents for Highway Works, Volume 3 : *Highway Construction Details* : 2001, Drawing No F13 (1991)



On behalf of the British Board of Agrément

A handwritten signature in black ink, appearing to read 'P. Q. Newson'.

Date of Fifth issue: 14th March 2003

Chief Executive

*\*Original Certificate issued on 12th January 1990. This amended version issued to include an additional product size (94 mm), a revised Table 1, reference to the Highways Agency, additional testing and MCHW requirements and the conversion of the Certificate into Detail Sheet format.*

British Board of Agrément

P O Box No 195, Bucknalls Lane  
Garston, Watford, Herts WD25 9BA

Fax: 01923 665301

©2003

e-mail: mail@bba.star.co.uk  
website: www.bbacerts.co.uk



For additional information about the Certificate, tel: 01923 665300.  
For information about Agrément Certificate validity and scope, tel: Hotline 01923 665400, or check the BBA website.



Polypipe Civils Ltd

COMTITE DUCTING PLUG

Roads and Bridges  
Certificate No 90/R049  
**DETAIL SHEET 3**

## Product

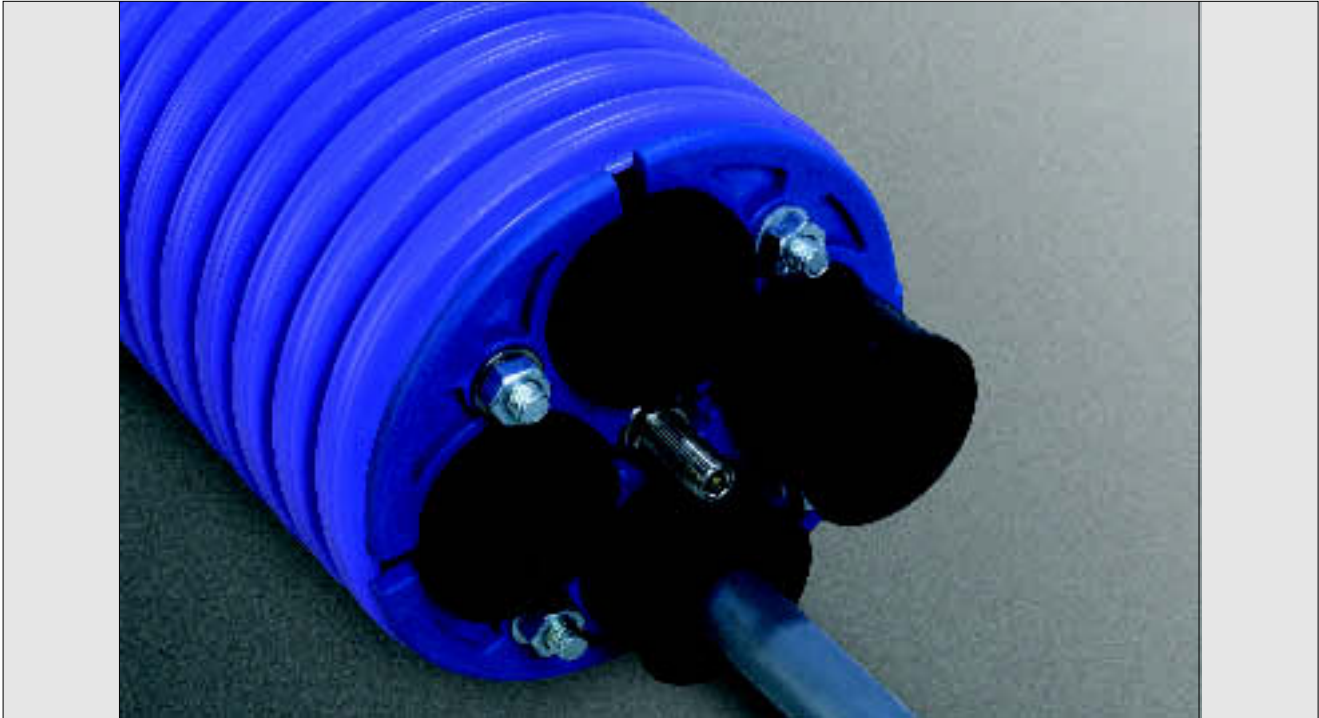

- THIS DETAIL SHEET RELATES TO THE COMTITE DUCTING PLUG.

- The product is for use in highways as underground ducting for electricity, and for street lighting cables and fibre optic cabling for telecommunications.

*This Detail Sheet must be read in conjunction with the Front Sheet which gives the Highways Agency (HA) requirements and the Conditions of Certification.*

## Technical Specification

### 1 Description

1.1 The Comtite Ducting Plug is made from black EPDM rubber, constructed of two parts, a male and female, which interlock and are held together with a centre bolt. This bolt incorporates a valve to release any pressure which may build up in the ducting during installation. The valve is also used for carrying out the air pressure test with the core valve part removed. There are eight compression plates, made from blue Acyral. Four plates on the top and four on the bottom, held together in pairs with bolts.

1.2 The product is constructed with four holes in which a selection of grommets can be inserted. The range of grommets are given in Table 1.

1.3 The product is available in two sizes to suit the 94 mm and 100 mm Ridgiduct pipe. Details of the construction of the Comtite Ducting Plug are given in Figure 1, and Table 1.

1.4 Ending the ducting system with the Comtite Ducting Plug produces a system with protection against penetration by solid foreign objects of

1 mm diameter or greater and against ingress of water at 1 metre depth, ie an IP rating of IP47 to BS EN 60529 : 1992.

Figure 1 Comtite

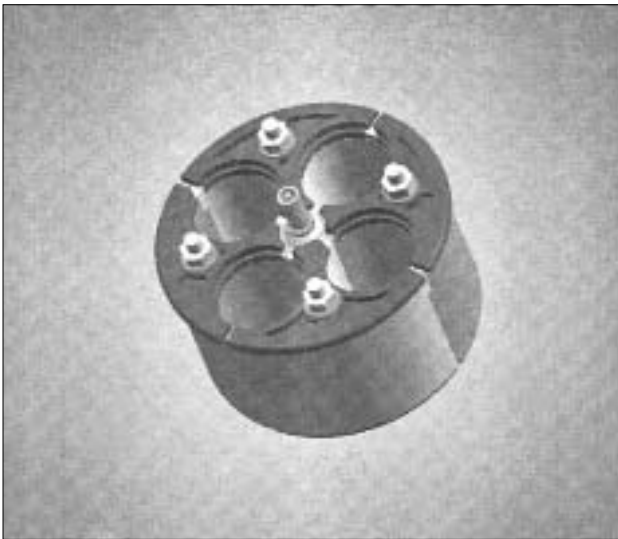

Table 1 Range of plugs and grommets

Product code	Description
DP 94	94 mm ducting plug
DP 100	100 mm ducting plug
DPG 0	blanking grommet
DPG 9	9 mm grommet
DPG 12	12 mm grommet
DPG 14	14 mm grommet
DPG 16	16 mm grommet
DPG 18	18 mm grommet
DPG 21	21 mm grommet
DPG 24	24 mm grommet
DPG 27	27 mm grommet
DPG 4 x 9	4 x 9 mm grommet
DPG 7 x 9	7 x 9 mm grommet

1.5 When using the Comtite Ducting Plug, the Ridgiduct RB 94 and RB 100 are suitable for motorway communications applications as a sealed system to BS EN 50086-2.4 : 1994.

1.6 Quality control includes checks on raw materials, dimensional checks, and air pressure test.

## 2 Delivery and site handling

2.1 The Comtite Ducting Plug is individually bagged and the grommets bagged in packs of five for each type of grommet.

2.2 The Comtite Ducting Plug has good resistance to UV degradation. When long term storage is envisaged, duct plugs must be stored away from direct sunlight.

## 3 General

The Comtite Ducting Plug, when installed in accordance with the recommendations given in this Detail Sheet, is suitable for use in highways for underground ducting for electricity services, and for street lighting cables and fibre optic cabling for cable television and telecommunications.

## 4 Strength

4.1 The product has adequate strength to resist the loads likely to be encountered during service when used and installed in accordance with the recommendations given in this Detail Sheet.

4.2 The product has adequate resistance to the impact loads normally encountered during handling and installation.

## 5 Resistance to elevated temperatures

5.1 The maximum temperature to which the duct plug will be subject in service as part of an electrical cable ducting system is dependent on the ground thermal conductivity, depth of burial, ground temperature and the heat load imposed by the electrical cable.

5.2 In general, cables with a surface temperature of up to 60°C will not affect the integrity of the duct plug. For example, in a typical installation with a 300 mm<sup>2</sup> copper cable carrying a current of 600 amps imposing a heat load of 25 Wm<sup>-1</sup>, the cable would have a surface temperature of 60°C.

## 6 Resistance to chemicals

The materials used to manufacture the Comtite Ducting Plugs have adequate resistance to attack from chemicals likely to occur in soils and groundwater. Details of chemical resistance of the materials are given in CP 312-1 : 1973.

## 7 Practicability of installation

The grommets have a high friction surface which would impede the installation or withdrawal of cables. To overcome this the grommets are split along their length to allow them to be clipped over the cable once it has been pulled through.

## 8 Durability

When used in the context of this Certificate, the Comtite Ducting Plug will have adequate durability.

## Installation

### 9 General

9.1 The Comtite Ducting Plug must be installed in accordance with the requirements of the manufacturer's instructions, and any additional site requirements (see section 1).

9.2 The general requirements for a ducting system are to be in accordance with sections 10 and 11 of Detail Sheet 1.

## Technical Investigations

The following is a summary of the technical investigations carried out on the Comtite Ducting Plug.

### 10 Tests

Tests were carried out to determine:

- dimensional accuracy
- airtightness to MCHW, Vol 1, Clause 509.2
- watertightness of joints to BS EN 60529 : 1992
- degree of protection against foreign objects to BS EN 60529 : 1992.

### 11 Investigations

11.1 An examination was made of data relating to:

- chemical resistance
- heat dissipation
- effect of temperature
- practicability of installation
- material properties
- durability.

11.2 The manufacturing process was examined, including the methods adopted for quality control, and details were obtained of the quality and composition of the materials used.

## Additional Information

The management systems of Polypipe Civils Ltd have been assessed and registered as meeting the requirements of BS EN ISO 9002 : 1994 by the British Standards Institution Quality Assurance.

## Bibliography

BS EN 50086-2.4 : 1994 *Specification for conduit systems for electrical installations — Particular requirements — Conduit systems buried underground*

BS EN 60529 : 1992 *Specification for degrees of protection provided by enclosures (IP Code)*

BS EN ISO 9002 : 1994 *Quality systems. Model for quality assurance in production, installation and servicing*

CP 312-1 : 1973 *Code of practice for plastics pipework (thermoplastics material) — General principles and choice of material*

Manual of Contract Documents for Highway Works, Volume 1 : *Specification for Highway Works* : May 2001 edition



On behalf of the British Board of Agrément

Date of issue: 14th March 2003

A handwritten signature in black ink, appearing to read 'P. C. Newson', is written over a light grey background.

Chief Executive

# Electronic Copy

---

**British Board of Agrément**  
P O Box No 195, Bucknalls Lane  
Garston, Watford, Herts WD25 9BA  
Fax: 01923 665301

©2003

e-mail: [mail@bba.star.co.uk](mailto:mail@bba.star.co.uk)  
website: [www.bbacerts.co.uk](http://www.bbacerts.co.uk)



For additional information about the Certificate, tel: 01923 665300.  
For information about Agrément Certificate validity and scope, tel: Hotline 01923 665400, or check the BBA website.