

Waterproofing Accessories Limited

PO Box 12753
Harlow
CM20 9RB



Tel: 03001245501

e-mail: enquiries@waterproofingaccessories.co.uk

website: www.waterproofingaccessories.com

Agrément Certificate

21/5893

Product Sheet 1

WATERPROOFING ACCESSORIES

WA/CD 8MM MEMBRANE

This Agrément Certificate Product Sheet⁽¹⁾ relates to WA/CD 8mm Membrane, a moulded high-density polyethylene (HDPE) membrane for damp-proofing walls, floors and vaulted ceilings in new construction or existing buildings. It is used above or below ground, over a contaminated or damp background, to support a dry lining and flooring.

(1) Hereinafter referred to as 'Certificate'.

CERTIFICATION INCLUDES:

- factors relating to compliance with Building Regulations where applicable
- factors relating to additional non-regulatory information where applicable
- independently verified technical specification
- assessment criteria and technical investigations
- design considerations
- installation guidance
- regular surveillance of production
- formal three-yearly review.



KEY FACTORS ASSESSED

Resistance to water and water vapour — the membrane is water resistant and has a high resistance to water vapour transmission (see section 6).

Resistance to salt transfer — the membrane provides an effective barrier to the transmission of salts or other contaminants from the substrate (see section 8).

Properties in relation to fire — the membrane is not classified in accordance with BS EN 13501-1 : 2018 and its use is restricted under the national Building Regulations in some cases (see section 9).

Resistance to puncture, impact and loading — the membrane has a high resistance to puncture and will not be damaged by normal foot traffic during installation or while laying concrete or screed. It can support the long-term loadings likely to be experienced in service without undue deformation (see section 10).

Durability — under normal conditions of use, the system will provide an effective barrier to the transmission of salts, liquid water and water vapour for the life of the structure in which it is incorporated (see section 13).



The BBA has awarded this Certificate to the company named above for the system described herein. This system has been assessed by the BBA as being fit for its intended use provided it is installed, used and maintained as set out in this Certificate.

On behalf of the British Board of Agrément

Date of First issue: 11 June 2021

Hardy Giesler
Chief Executive Officer

The BBA is a UKAS accredited certification body – Number 113.

The schedule of the current scope of accreditation for product certification is available in pdf format via the UKAS link on the BBA website at www.bbacerts.co.uk

Readers **MUST** check the validity and latest issue number of this Agrément Certificate by either referring to the BBA website or contacting the BBA directly.

Any photographs are for illustrative purposes only, do not constitute advice and should not be relied upon.

British Board of Agrément

Bucknalls Lane
Watford
Herts WD25 9BA

©2021

tel: 01923 665300
clientservices@bbacerts.co.uk
www.bbacerts.co.uk

Regulations

In the opinion of the BBA, WA/CD 8mm Membrane, if installed, used and maintained in accordance with this Certificate, can satisfy or contribute to satisfying the relevant requirements of the following Building Regulations (the presence of a UK map indicates that the subject is related to the Building Regulations in the region or regions of the UK depicted):



The Building Regulations 2010 (England and Wales) (as amended)

Requirement:	B3(3)(4)	Internal fire spread – structure
Comment:		The system can contribute to satisfying this Requirement. See section 9.1 of this Certificate.
Requirement:	B4(1)	External fire spread
Comment:		The system is restricted by this Requirement. See section 9 of this Certificate.
Requirement:	C2(a)(b)	Resistance to moisture
Comment:		The system adequately resists the passage of moisture. See section 6.1 of this Certificate.
Regulation:	7(1)	Materials and workmanship
Comment:		The system is acceptable. See section 13 and the <i>Installation</i> part of this Certificate.



The Building (Scotland) Regulations 2004 (as amended)

Regulation:	8(1)	Durability, workmanship and fitness of materials
Comment:		The system is acceptable. See section 13 and the <i>Installation</i> part of this Certificate.
Regulation:	9	Building standards applicable to construction
Standard:	2.4	Cavities
Comment:		The system can contribute to satisfying this Standard with respect to clause 2.4.2 ⁽¹⁾⁽²⁾ . See section 9.1 of this Certificate.
Standard:	3.3	Flooding and ground water
Comment:		The system can contribute to minimising or eliminating the effects of flooding on the building fabric and/or the building element, with reference to clause 3.3.1 ⁽¹⁾⁽²⁾ of this Standard. See section 6.1 of this Certificate.
Standard:	3.4	Moisture from the ground
Comment:		The system adequately resists the passage of moisture, with reference to clauses 3.4.1 ⁽¹⁾⁽²⁾ , 3.4.2 ⁽¹⁾⁽²⁾ , 3.4.5 ⁽¹⁾⁽²⁾ , 3.4.6 ⁽¹⁾⁽²⁾ and 3.4.7 ⁽¹⁾⁽²⁾ of this Standard. See section 6.1 of this Certificate.
Standard:	3.6(a)	Surface water drainage
Comment:		The system can contribute to satisfying this Standard, with reference to clause 3.6.3 ⁽¹⁾⁽²⁾ . See section 6.1 of this Certificate.
Standard:	3.10	Precipitation
Comment:		The system adequately resists the passage of moisture, with reference to clause 3.10.1 ⁽¹⁾⁽²⁾ of this Standard. See section 6.1 of this Certificate.
Standard:	7.1(a)	Statement of sustainability
Comment:		The system can contribute to satisfying the relevant requirements of Regulation 9, Standards 1 to 6, and therefore will contribute to a construction meeting a bronze level of sustainability as defined in this Standard.

Regulation:	12	Building standards applicable to conversions
Comment:	Comments in relation to the system under Regulation 9, Standards 1 to 6, also apply to this Regulation, with reference to clause 0.12.1 ⁽¹⁾⁽²⁾ and Schedule 6 ⁽¹⁾⁽²⁾ .	
	(1) Technical Handbook (Domestic). (2) Technical Handbook (Non-Domestic).	



The Building Regulations (Northern Ireland) 2012 (as amended)

Regulation:	23(a)(i)	Fitness of materials and workmanship
Comment:	(iii)(b)(i)	The system is acceptable. See section 13 and the <i>Installation</i> part of this Certificate.
Regulation:	28(a)(b)	Resistance to moisture and weather
Comment:		The system adequately resists the passage of moisture. See section 6.1 of this Certificate.
Regulation:	35(3)(4)	Internal fire spread – structure
Comment:		The system can contribute to satisfying this Regulation. See section 9.1 of this Certificate.

Construction (Design and Management) Regulations 2015

Construction (Design and Management) Regulations (Northern Ireland) 2016

Information in this Certificate may assist the client, designer (including Principal Designer) and contractor (including Principal Contractor) to address their obligations under these Regulations.

See sections: 1 *Description* (1.1) and 3 *Delivery and site handling* (3.4) of this Certificate.

Additional Information

NHBC Standards 2021

In the opinion of the BBA, WA/CD 8mm Membrane, if installed, used and maintained in accordance with this Certificate, can satisfy or contribute to satisfying the relevant requirements in relation to *NHBC Standards*, Chapters 5.1 *Substructure and ground bearing floors*, 5.2 *Suspended ground floors* and 5.4 *Waterproofing of basements and other below ground structures*.

Where Grade 3 waterproofing protection is required, and the below-ground wall retains more than 600 mm (measured from the top of the retained ground to the lowest finished floor level), the system should be used in combination with either a Type A or B waterproofing protection.

In the opinion of the BBA, the use of the system on existing structures, when installed and used in accordance with this Certificate, can satisfy or contribute to satisfying the relevant requirements in relation to *NHBC Standards for Conversions and Renovations*, taking account of other relevant guidance within the chapter and the suitability of the substrate to receive the system.

CE marking

The Certificate holder has taken the responsibility of CE marking the membrane in accordance with harmonised European Standard BS EN 13967 : 2012.

1 Description

1.1 WA/CD 8mm Membrane is a translucent, HDPE sheet with moulded studs, for use as a damp-proofing membrane. The membrane is available in the following dimensions:

Thickness (mm)	0.5
Stud height (mm)	8
Weight per unit area ($\text{kg}\cdot\text{m}^{-2}$)	0.5
Roll length (m)	20
Roll width (m) ⁽¹⁾	2.0 and 2.4
Weight per roll (kg)	22 and 26
Air gap volume ($\text{l}\cdot\text{m}^{-2}$)	5.3.

(1) Includes a 70 mm flanged stud-free area for overlapping sheets.

1.2 Ancillary items used with the membrane include:

- WA Quickfix Plug — a plastic plug supplied with preformed rubber seal for use in masonry walls and concrete (see Figure 1)
- WA Plug — glass-filled nylon plug for use in masonry walls and concrete (see Figure 2)
- WA Tape — black butyl tape for sealing joints in the membrane
- WA Bead — black butyl beading for sealing the membrane around pipes and openings, joining floor and wall membranes, and to seal around the head of WA Plugs prior to fixing the membrane
- WA Detailing Strip — a self-adhesive membrane strip for sealing junctions between walls and floors, and for sealing joints at corners
- WA Fleece-Tape — 100 mm wide butyl tape with fleece backing for sealing joints in the membrane. The fleece backing will form a bond with the plaster when used with meshed membranes
- WA Primer — a solvent-based primer for sealing porous substrates prior to application of the WA range of butyl-based sealing products.

Figure 1 WA Quickfix Plug fixing detail

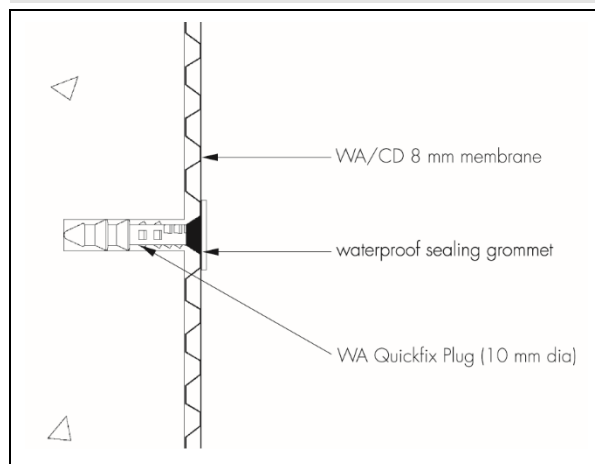
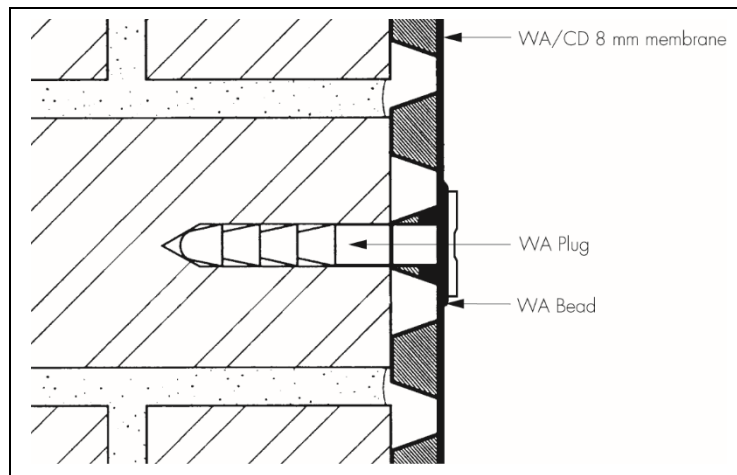

Figure 2 WA Plug fixing detail



2 Manufacture

2.1 The membrane is formed in a continuous process in which HDPE is extruded into sheets and the stud impression formed.

2.2 As part of the assessment and ongoing surveillance of product quality, the BBA has:

- agreed with the manufacturer the quality control procedures and product testing to be undertaken
- assessed and agreed the quality control operated over batches of incoming materials
- monitored the production process and verified that it is in accordance with the documented process
- evaluated the process for management of nonconformities
- checked that equipment has been properly tested and calibrated
- undertaken to carry out the above measures on a regular basis through a surveillance process, to verify that the specifications and quality control operated by the manufacturer are being maintained.

3 Delivery and site handling

3.1 The membrane is delivered to site in rolls secured with outer wrapping, and a headband bearing the product and manufacturer's name.

3.2 Rolls should be stored on end, under cover and protected from sharp objects, sunlight and high temperatures.

3.3 The packaging details of the ancillary items are shown in Table 1.

Table 1 Packaging details

Item	Dimensions/volume	Packaging/quantity
WA Quickfix Plug	10 mm diameter 58 mm long	Boxes of 100
WA Plug	11 mm diameter 70 mm long	Boxes of 100 or 1000
WA Tape	22.5 m long 28 mm wide 2 mm thick	1 roll per box 10 rolls per outer box
WA Bead	4.75 m long 10 mm diameter	1 roll per box 10 rolls per outer box
WA Mastic	0.4 litre cartridge	24 cartridges per box
WA Detailing Strip	20 m long 150 mm wide	Single rolls 2 rolls per box
WA Fleece-Tape	20 m long 100 mm wide 0.9 mm thick	1 roll per box
WA Primer	10 litres	Single 10-litre tin

3.4 The Certificate holder has taken the responsibility of classifying and labelling the membrane under the *CLP Regulation (EC) No 1272/2008 on the classification, labelling and packaging of substance and mixtures*. Users must refer to the relevant Safety Data Sheet(s).

Assessment and Technical Investigations

The following is a summary of the assessment and technical investigations carried out on WA/CD 8mm Membrane.

Design Considerations

4 General

4.1 WA/CD 8mm Membrane is satisfactory for use to damp-proof walls, floors and vaulted ceilings, above and below ground, in new construction or in existing buildings over a contaminated or damp background. It can support a dry lining, screed or flooring in the following situations:

- on damp walls and floors in underground situations subject to high groundwater levels and perennial moisture
- on vaulted ceilings of archways or cellars subject to water ingress
- in conjunction with a remedial dpc system where the walls and floors have a high salt content, and/or where it is necessary to complete the installation immediately without allowing a period for initial drying
- over walls and floors which have a friable or painted surface, are contaminated (eg with oil or mould) or have a high salt content
- as a waterproofing membrane in areas subject to vibration.

4.2 Depending on the application required and the site conditions, the membrane may be used as:

- an underfloor damp-proof membrane
- a dry lining for walls, ventilated into the room via aeration slots at the top and bottom of the wall or via passive air vents, where access through an external wall is available
- a sealed system covering wall, floor and ceiling, with provision made for disposing of water build-up behind the membrane via a sump and pump.

4.3 The membrane has not been assessed for use in chemically contaminated areas, such as brownfield sites.

4.4 The system is satisfactory for use in Type C (drained protection) constructions in accordance with BS 8102 : 2009.

4.5 Under normal operating conditions, the membrane is not affected by underfloor heating.

5 Practicability of installation

The membrane is designed to be installed by competent specialist contractors experienced with damp-proofing work.

6 Resistance to water and water vapour



6.1 The membrane is water resistant and has a high resistance to water vapour transmission. However, the system as installed is not resistant to hydrostatic pressure and, consequently, the measures described in the *Installation* part of this Certificate must be followed to ensure that the membrane acts as a drainage layer with no excessive build-up of water behind the system.

6.2 All joints and fixings must be sealed with WA sealing products; drainage channels and gullies, or sumps and pumps, should be installed as necessary to disperse excess or standing water.

7 Risk of condensation

7.1 As with any room, there is a need to control the generation and dispersal of moisture in the internal environment and to select appropriate and robust designs to minimise the risk of both surface and interstitial condensation, especially where insulation is used over the membrane.

7.2 In common with most waterproofing membranes, the system has a very high resistance to vapour diffusion, and when placed on the cold side of a construction may increase the risk of interstitial condensation. A calculation should be carried out to BS 5250 : 2011 and designers should consider appropriate techniques for managing the safe egress of moisture vapour (such as control of the internal room environment or use of a vapour control layer on the warm side of the insulation), and in particular the effect of moisture on any materials at, or in contact with materials below, the local dew-point.

8 Resistance to salt transfer

The membrane provides an effective barrier to the transmission of salts or other contaminants from the substrate.

9 Properties in relation to fire



9.1 The membrane is not classified in accordance with BS EN 13501-1 : 2018. Where the system forms the face of a cavity the permissible areas of use and the spacing of cavity barriers are restricted by the national Building Regulations.



9.2 In England, when used as part of the external wall above ground level, the membrane should not be used on buildings that have a storey at least 18 m above ground level and which contain: one or more dwellings, an institution, a room for residential purposes (excluding any room in a hostel, hotel or boarding house), student accommodation, care homes, sheltered housing, hospitals or dormitories in boarding schools.

10 Resistance to puncture, impact and loading

10.1 The membrane has a high resistance to puncture and will not be damaged by normal foot traffic during installation or while laying concrete or screed to BS 8204-1 : 2003.

10.2 The membrane can support the long-term imposed loadings defined in the UK National Annex to BS EN 1991-1-1 : 2002, Table NA.2, Categories A to D, without undue deformation.

11 Wall-mounted fittings

Wall-mounted fittings (apart from lightweight items such as framed pictures) should be fixed where possible into battens, whose position and number of support fixings into the loadbearing structure are predetermined. Only in exceptional circumstances should fittings be fixed⁽¹⁾ through the membrane and lining board to the loadbearing structure behind. Holes made in the membrane must be repaired in accordance with the Certificate holder's recommended procedures.

(1) Using proprietary fixings.

12 Maintenance

12.1 As the membrane is confined within a wall or floor space and has suitable durability (see section 13), maintenance is not required.

12.2 Regular maintenance of all gullies, sumps and pumps must be conducted to ensure that a build-up of water does not occur behind the membrane.

13 Durability



Under normal conditions of use, the system will provide an effective barrier to the transmission of salts, liquid water and water vapour for the life of the structure in which it is incorporated.

14 Reuse and recyclability

The membrane is made from HDPE, which can be recycled.

Installation

15 Survey

15.1 Where the property is below ground, or where conditions are damp, a full survey by a specialist waterproofing surveyor is necessary, to diagnose the cause and to establish if treatment is required.

15.2 If rising damp to above-ground elevations is found, a remedial treatment is conducted in accordance with the relevant BBA Certificate, BS 6576 : 2005 and the Property Care Association *Code of Practice for Installation of Remedial Damp-proof Courses in Masonry Walls*.

15.3 Appropriate remedial measures are taken to rectify major causes of damp conditions or water ingress, and to repair structural defects.

16 Surface preparation

16.1 When used in new constructions, the concrete base must be laid in accordance with BS 8204-1 : 2003.

16.2 If a board covering is to be laid directly on the membrane, the concrete base must have a surface regularity with a maximum permissible departure of 5 mm from the underside of a 2 m straight edge, resting in contact with the floor, in accordance with BS 8204-1 : 2003.

16.3 When used in existing buildings any unsound plaster, render or screed is removed to expose the substrate which is then cleaned with a stiff brush to remove loose material, laitance, salt residue, mould or adhesive. If mould is present, the substrate is treated with a fungicidal wash.

16.4 Uneven floor substrates should be dubbed out with a cement-sand (1:4) or cement-lime-sand (1:1:6) render or screed, to the tolerance described in section 16.2, and allowed to dry thoroughly before WA/CD 8mm Membrane is installed above.

17 Procedure

General

17.1 WA/CD 8mm Membrane may be used in combination with any of the appropriate WA membranes that are the subjects of other Product Sheets of this Certificate.

17.2 The membrane should be used with the flanged edge positioned in front of, and overlapping, the previously installed membrane width. Joints with the flanged edge are sealed using WA Tape, while stud-to-stud joints (without the flanged edge) are sealed by overlapping the membrane by a minimum of three studs and positioning WA Bead between the last two rows of studs or oversealing the joint with WA Detailing Strip or WA Fleece-Tape.

17.3 Fixings are made through the membrane into 10 mm holes drilled centrally through the studs. WA Quickfix Plugs are inserted into the holes and hammered flush with the membrane with a club hammer.

17.4 Alternatively, fixings are made through 11 mm holes drilled centrally through the studs. WA Bead (to which WA Bead has been applied around the shaft, next to the head) are inserted into the holes and hammered flush with the membrane. WA Bead forms a sealing gasket between the plug and the membrane.

17.5 On difficult substrates, the translucent nature of the membrane allows the contractor to view the substrate through the membrane and choose the optimum site for each fixing.

17.6 On walls and ceilings, preservative-treated timber battens of minimum dimensions 25 by 38 mm are fixed into the WA Plug's fixing hole using No 12 screws, or WA Quickfix Plug's fixing hole using No 10 screws, with a maximum screwing-in depth of 30 mm. The membrane can also be dry-lined, using free-standing framework, blockwork or similar. Where necessary, these should be tied back by fixing into the WA Plug, WA Quickfix Plug.

Walls

17.7 Installation of the membrane is usually commenced at the top of the construction. The membrane may require initial fixing on a ceiling or along the upper edge of a wall, prior to final fixings along batten runs. For joints where the flanged edge is not used, the two membrane sheets are overlapped by a minimum of 100 mm. For horizontal joints, the lower sheet is always positioned in front of the upper sheet.

17.8 Spacing between fixings will depend on the method of dry lining to be applied. When using preservative-treated timber battens, the fixings should be spaced at 600 mm centres. Proprietary metal fast track systems and independent frame systems will require fewer fixings, but sufficient should be used to ensure that the membrane is reasonably tight to the wall, especially at corners.

17.9 The installation is conducted over windows and the membrane is cut away to expose them. The gaps are then sealed with WA Tape, WA Bead or WA Detailing Strip.

17.10 For doors and some obstructions, the technique covered in section 17.9 cannot be used. Instead, the membrane is installed up to the perimeter and the gap sealed in the same manner.

17.11 Power cables, points and light switches should preferably be remounted in front of the membrane.

17.12 In below-ground installations, the practice of leaving the top of the wall membrane unsealed where there is no requirement for a ceiling membrane to be installed may need to be reconsidered in cases where ingress of gases, odours or vermin is a concern (such as in proximity to food preparation areas). The advice of the Certificate holder should be sought in these situations.

17.13 In above-ground installations, the build-up of water vapour behind the membrane is controlled by venting into the room via ventilation gaps provided at the ceiling and skirting board levels or via passive air vents, where access through an external wall is available.

Ceilings

17.14 Ceilings to be covered must always have a fall, as per vaulted cellar constructions, to ensure water does not lie against the membrane or a joint. Membrane sheets should have an overlap of 200 mm.

17.15 WA Quickfix Plugs, or WA Plugs sealed with WA Bead should be used to fix the membrane to vaulted ceilings. Any sagging of the membrane between fixing points on ceilings should not be great enough for ponding to occur.

17.16 At the end walls of vaulted constructions, the membrane must be turned down onto the end wall by a minimum 200 mm. The membrane is mitred as necessary to fit the curve of the ceiling, and the joints sealed with WA Tape, WA Bead, WA Detailing Strip or WA Fleece-Tape. The wall membrane should be cut into the curve of the ceiling, fixed in front of the ceiling membrane and the gap sealed with WA Bead.

Floors

17.17 Floors should have a drainage outlet point. There should be a fall towards the outlet point, or a drainage channel made around the circumference of the floor, to ensure that water can flow to the outlet.

17.18 The membrane is rolled out 'studs down' over the floor, and consecutive membrane widths are laid so the flanged edge overlaps the first sheet by three studs, and the joints sealed with WA Tape. Stud-to-stud joints can be over-sealed using WA Detailing Strip or WA Fleece-Tape in accordance with section 17.2.

17.19 The membrane is cut within 5 mm of any pipes and services in the floor, and the gap filled with WA Bead. If necessary, a patch of membrane is overlaid and sealed to the services with WA Bead, and its perimeter sealed with WA Tape or WA Detailing Strip.

17.20 Fixings must not be applied through the floor membrane.

17.21 Where appropriate, at wall/floor junctions and corners of the installation, the membrane may be cut flush and the gap between the wall and floor membranes sealed with WA Detailing Strip or WA Fleece-Tape. Alternatively, the floor membrane may be turned up by 100 mm at the wall.

17.22 Where internal or external corners occur, they should be oversealed using WA Detailing Strip or WA Fleece-Tape, in accordance with the Certificate holder's installation instructions.

18 Dry lining of walls

Gypsum plasterboard to BS EN 520 : 2004, or similar dry lining boards which are the subject of a current BBA Certificate, are fixed to the battens with galvanized screws or nails positioned a minimum of 12 mm from the edge of the board. To avoid puncturing the membrane, care should be taken to ensure that penetration of the plasterboard screws or nails is less than the batten depth.

19 Finishing works

After the system has been installed and the walls dry-lined, permanent decorations (such as vinyl paper or oil paint) may be applied. Temporary permeable decorations (necessary with traditional, cement-based waterproofers) are not necessary with the system.

20 Floor membrane coverings

20.1 If required, extruded closed-cell polystyrene insulation boards, minimum density $30 \text{ kg}\cdot\text{m}^{-3}$, may be laid over the membrane.

20.2 Suitable tongue-and-groove flooring board panels should be selected in accordance with BS EN 12871 : 2013, and loose-laid over the membrane to within 10 mm of the walls. The panels are staggered and the joints sealed with a thermoplastic wood adhesive to BS EN 204 : 2016.

20.3 Alternatively, the membrane is covered by concrete or screed of minimum thickness 50 mm (or minimum 65 mm thickness if laid over insulation boards) in accordance with BS 8204-1 : 2003. Care should be taken to ensure the

membrane is not displaced when placing the concrete or screed. The concrete screed should be reinforced to inhibit shrinkage cracks.

20.4 Proprietary screeds, which can generally be laid at thicknesses less than 50 mm, may also be considered but their use with the membrane has not been assessed by the BBA and is outside the scope of this Certificate.

Technical Investigations

21 Tests

21.1 An assessment was made of data in relation to:

- thickness of membrane
- mass per unit area of membrane
- watertightness of membrane to liquid water
- resistance to impact
- water vapour transmission of the membrane
- resistance to static loading
- durability of watertightness against heat ageing
- durability of watertightness against chemicals
- tensile strength of membrane
- elongation of membrane
- reaction to fire.

21.2 Tests were carried out, and the results evaluated, to determine water vapour permeability of the membrane incorporating a joint.

22 Investigations

22.1 A user survey of treated installations and contractors was conducted to establish the system's performance in use.

22.2 Visits were made to sites in progress to assess the practicability of installation in respect of sealing lap joints and corners, dry lining and flooring finishing works.

22.3 An assessment was made of the scope of use and durability of the system in relation to the generic properties of the membrane.

22.4 The manufacturing process was evaluated, including the methods adopted for quality control, and details were obtained of the quality and composition of the materials used.

Bibliography

BS 5250 : 2011 + A1 : 2016 *Code of practice for control of condensation in buildings*

BS 6576 : 2005 + A1 : 2012 *Code of practice for diagnosis of rising damp in walls of buildings and installation of chemical damp-proof courses*

BS 8102 : 2009 *Code of practice for protection of below ground structures against water from the ground*

BS 8204-1 : 2003 + A1 : 2009 *Screeds, bases and in-situ floorings — Concrete bases and cement sand levelling screeds to receive floorings — Code of practice*

BS EN 204 : 2016 *Classification of thermoplastic wood adhesives for non-structural applications*

BS EN 520 : 2004 + A1 : 2009 *Gypsum plasterboards — Definitions, requirements and test methods*

NA to BS EN 1991-1-1 : 2002 UK National Annex to *Eurocode 1 : Actions on structures — General actions— Densities, self-weight, imposed loads for buildings*

BS EN 12871 : 2013 *Wood-based panels — Determination of performance characteristics for load bearing panels for use in floors, roofs and walls*

BS EN 13501-1 : 2018 *Fire Classification of construction products and building elements – Classifications from reaction to fire tests*

BS EN 13967 : 2012 + A1 : 2017 *Flexible sheets for waterproofing — Plastic and rubber damp proof sheets including plastic and rubber basement tanking sheet — Definitions and characteristics*

Property Care Association COP02 *Code of Practice for Installation of Remedial Damp-proof Courses in Masonry Walls*

23 Conditions

23.1 This Certificate:

- relates only to the product/system that is named and described on the front page
- is issued only to the company, firm, organisation or person named on the front page – no other company, firm, organisation or person may hold or claim that this Certificate has been issued to them
- is valid only within the UK
- has to be read, considered and used as a whole document – it may be misleading and will be incomplete to be selective
- is copyright of the BBA
- is subject to English Law.

23.2 Publications, documents, specifications, legislation, regulations, standards and the like referenced in this Certificate are those that were current and/or deemed relevant by the BBA at the date of issue or reissue of this Certificate.

23.3 This Certificate will remain valid for an unlimited period provided that the product/system and its manufacture and/or fabrication, including all related and relevant parts and processes thereof:

- are maintained at or above the levels which have been assessed and found to be satisfactory by the BBA
- continue to be checked as and when deemed appropriate by the BBA under arrangements that it will determine
- are reviewed by the BBA as and when it considers appropriate.

23.4 The BBA has used due skill, care and diligence in preparing this Certificate, but no warranty is provided.

23.5 In issuing this Certificate the BBA is not responsible and is excluded from any liability to any company, firm, organisation or person, for any matters arising directly or indirectly from:

- the presence or absence of any patent, intellectual property or similar rights subsisting in the product/system or any other product/system
- the right of the Certificate holder to manufacture, supply, install, maintain or market the product/system
- actual installations of the product/system, including their nature, design, methods, performance, workmanship and maintenance
- any works and constructions in which the product/system is installed, including their nature, design, methods, performance, workmanship and maintenance
- any loss or damage, including personal injury, howsoever caused by the product/system, including its manufacture, supply, installation, use, maintenance and removal
- any claims by the manufacturer relating to CE marking.

23.6 Any information relating to the manufacture, supply, installation, use, maintenance and removal of this product/system which is contained or referred to in this Certificate is the minimum required to be met when the product/system is manufactured, supplied, installed, used, maintained and removed. It does not purport in any way to restate the requirements of the Health and Safety at Work etc. Act 1974, or of any other statutory, common law or other duty which may exist at the date of issue or reissue of this Certificate; nor is conformity with such information to be taken as satisfying the requirements of the 1974 Act or of any statutory, common law or other duty of care.